

**San Francisco Bay Regional Water Quality Control Board**

**ORDER No. R2-2015-0045  
NPDES No. CA0038733**

The following discharger is subject to waste discharge requirements (WDRs) set forth in this Order:

**Table 1. Discharger Information**

<b>Discharger</b>	Union Sanitary District
<b>Facility Name</b>	Raymond A. Boege Alvarado Wastewater Treatment Plant - Old Alameda Creek Intermittent Wet Weather Discharge
<b>Facility Address</b>	5072 Benson Road Union City, CA 94587 Alameda County
<b>CIWQS Place Number</b>	269044

**Table 2. Discharge Locations**

<b>Discharge Point</b>	<b>Effluent Description</b>	<b>Discharge Point Latitude (North)</b>	<b>Discharge Point Longitude (West)</b>	<b>Receiving Water</b>
001	Secondary-treated municipal wastewater	37.59397	-122.09192	Old Alameda Creek

**Table 3. Administrative Information**

This Order was adopted on:	November 18, 2015
This Order shall become effective on:	January 1, 2016
This Order shall expire on:	December 31, 2020
CIWQS Regulatory Measure Number	403703
The Discharger shall file a Report of Waste Discharge as an application for reissuance of WDRs in accordance with California Code of Regulations, title 23, and an application for reissuance of a National Pollutant Discharge Elimination System (NPDES) permit no later than:	April 30, 2020
The U.S. Environmental Protection Agency (U.S. EPA) and the California Regional Water Quality Control Board, San Francisco Bay Region, have classified this discharge as follows:	Minor

I, Bruce H. Wolfe, Executive Officer, do hereby certify that this Order with all attachments is a full, true, and correct copy of the Order adopted by the California Regional Water Quality Control Board, San Francisco Bay Region, on the date indicated above.

\_\_\_\_\_  
Bruce H. Wolfe, Executive Officer

## Contents

I.	Facility Information .....	3
II.	Findings.....	3
III.	Discharge Prohibitions.....	3
IV.	Effluent Limitations and Discharge Specifications .....	4
V.	Receiving Water Limitations .....	4
VI.	Provisions.....	6
	A. Standard Provisions.....	6
	B. Monitoring and Reporting .....	6
	C. Special Provisions .....	6
	1. Reopener Provisions.....	6
	2. Effluent Characterization Study and Report .....	7
	3. Receiving Water Characterization Study and Report.....	8
	4. Pollutant Minimization Program .....	8

## Tables

Table 1.	Discharger Information.....	1
Table 2.	Discharge Locations .....	1
Table 3.	Administrative Information .....	1
Table 4.	Effluent Limitations.....	4

## Attachments

Attachment A –	Definitions .....	A-1
Attachment B –	Facility Map.....	B-1
Attachment C –	Process Flow Diagram.....	C-1
Attachment D –	Federal Standard Provisions.....	D-1
Attachment E –	Monitoring and Reporting Program (MRP).....	E-1
Attachment F –	Fact Sheet.....	F-1
Attachment G –	Regional Standard Provisions and Monitoring and Reporting Requirements .....	G-1

## I. FACILITY INFORMATION

Information describing the Union Sanitary District Raymond A. Boege Alvarado Wastewater Treatment Plant, Old Alameda Creek Intermittent Wet Weather Discharge (Facility) is summarized in Table 1 and Fact Sheet (Attachment F) sections I and II.

## II. FINDINGS

The California Regional Water Quality Control Board, San Francisco Bay Region (Regional Water Board), finds:

- A. Legal Authorities.** This Order serves as WDRs pursuant to California Water Code article 4, chapter 4, division 7 (commencing with § 13260). This Order is also issued pursuant to federal Clean Water Act (CWA) section 402 and implementing regulations adopted by U.S. EPA and Water Code chapter 5.5, division 7 (commencing with § 13370). It shall serve as an NPDES permit for point source discharges from the Facility to surface waters.
- B. Background and Rationale for Requirements.** The Regional Water Board developed the requirements in this Order based on information the Discharger submitted as part of its application, information obtained through monitoring and reporting programs, and other available information. The Fact Sheet contains background information and rationale for the requirements in this Order and is hereby incorporated into and constitutes findings for this Order. Attachments A through E and G are also incorporated into this Order.
- C. Provisions and Requirements Implementing State Law.** No provision or requirement in this Order is included to implement State law only.
- D. Notification of Interested Parties.** The Regional Water Board notified the Discharger and interested agencies and persons of its intent to prescribe these WDRs and provided an opportunity to submit written comments and recommendations. The Fact Sheet provides details regarding the notification.
- E. Consideration of Public Comment.** The Regional Water Board, in a public meeting, heard and considered all comments pertaining to the discharge. The Fact Sheet provides details regarding the public hearing.

**THEREFORE, IT IS HEREBY ORDERED** that Order No. R2-2010-0097 is rescinded upon the effective date of this Order except for enforcement purposes, and, in order to meet the provisions of Water Code division 7 (commencing with § 13000) and regulations adopted thereunder and the provisions of the CWA and regulations and guidelines adopted thereunder, the Discharger shall comply with the requirements in this Order. This action in no way prevents the Regional Water Board from taking enforcement action for past violations of the previous order.

## III. DISCHARGE PROHIBITIONS

- A.** Discharge of treated wastewater at a location or in a manner different from that described in this Order is prohibited.
- B.** Discharge to Old Alameda Creek is prohibited, except during peak wet weather flows after the Discharger fully utilizes the maximum hydraulic capacity available in the East Bay Dischargers

Authority (EBDA) pipeline and except during exercise of the discharge flap gate as described in Prohibition III.D. Discharge during flap gate exercises shall not exceed 140,000 gallons per discharge event, with compliance measured at Monitoring Location EFF-WW as described in the Monitoring and Reporting Program (MRP, Attachment E).

- C. The bypass of untreated or partially-treated wastewater to waters of the United States is prohibited, except as provided for in Attachment D sections I.G.2 and I.G.3 of this Order.
- D. Discharge to Old Alameda Creek during discharge flap gate exercises more than twice per year is prohibited and shall only take place during the wet season, November 1 to April 30, when there is a significant flow increase in Old Alameda Creek.

#### IV. EFFLUENT LIMITATIONS AND DISCHARGE SPECIFICATIONS

Discharges at Discharge Point No. 001 shall comply with the following effluent limitations, with compliance measured at Monitoring Location M-002D (or, for total residual chlorine, Monitoring Location EFF-WW) as described in the MRP:

**Table 4. Effluent Limitations**

Parameter	Unit	Effluent Limitations				
		Average Monthly	Average Weekly	Maximum Daily	Instantaneous Minimum	Instantaneous Maximum
Carbonaceous Biochemical Oxygen Demand (5-day @ 20°C) (CBOD <sub>5</sub> )	mg/L	---	40	---	---	---
Total Suspended Solids (TSS)	mg/L	---	45	---	---	---
Oil and Grease	mg/L	---	---	20	---	---
pH <sup>[1]</sup>	standard units	---	---	---	6.5	8.5
Lead, Total	µg/L	3.4	---	8.3	---	---
Fecal Coliform	MPN/100 mL	---	---	400	---	---
Total Residual Chlorine	mg/L	---	---	---	---	0.0

Unit Abbreviations:

mg/L = milligrams per liter  
 µg/L = micrograms per liter  
 MPN/100 mL = most probable number per 100 milliliters

Footnote:

<sup>[1]</sup> If the Discharger monitors pH continuously, pursuant to 40 C.F.R. section 401.17 the Discharger shall be in compliance with this pH limitation provided that both of the following conditions are satisfied: (i) the total time during which the pH is outside the required range shall not exceed 7 hours and 26 minutes in any calendar month; and (ii) no individual excursion from the required pH range shall exceed 60 minutes.

#### V. RECEIVING WATER LIMITATIONS

- A. The discharge shall not cause the following conditions to exist in receiving waters:
  1. Floating material, including solids, liquids, foams, and scum, in concentrations that cause nuisance or adversely affect beneficial uses;
  2. Alteration of suspended sediment in such a manner as to cause nuisance or adversely affect beneficial uses, or detrimental increase in the concentrations of toxic pollutants in sediments or aquatic life;

3. Suspended material in concentrations that cause nuisance or adversely affect beneficial uses;
  4. Bottom deposits or aquatic growths to the extent that such deposits or growths cause nuisance or adversely affect beneficial uses;
  5. Alteration of temperature beyond present natural background levels such that the temperature alteration adversely affects beneficial uses;
  6. Changes in turbidity that cause nuisance or adversely affect beneficial uses, or increases from normal background light penetration or turbidity greater than 10 percent in areas where natural turbidity is greater than 50 nephelometric turbidity units;
  7. Coloration that causes nuisance or adversely affects beneficial uses;
  8. Visible, floating, suspended, or deposited oil or other products of petroleum origin; or
  9. Toxic or other deleterious substances in concentrations or quantities that cause deleterious effects on wildlife, waterfowl, or other aquatic biota, or render any of these unfit for human consumption, either at levels created in the receiving waters or as a result of biological concentration.
- B.** The discharge shall not cause the following limitations to be exceeded in receiving waters at any place within one foot of the water surface:
1. Dissolved Oxygen                      5.0 mg/L, minimum  

The median dissolved oxygen concentration for any three consecutive months shall not be less than 80% of the dissolved oxygen content at saturation. When natural factors cause concentrations less than that specified above, the discharge shall not cause further reduction in ambient dissolved oxygen concentrations.
  2. Dissolved Sulfide                      Natural background levels
  3. pH    Within range from 6.5 to 8.5
  4. Nutrients                                      Waters shall not contain biostimulatory substances in concentrations that promote aquatic growths to the extent that such growths cause nuisance or adversely affect beneficial uses.
- C.** The discharge shall not cause a violation of any water quality standard for receiving waters adopted by the Regional Water Board or the State Water Resources Control Board (State Water Board) as required by the CWA and regulations adopted thereunder. If more stringent water quality standards are promulgated or approved pursuant to CWA section 303, or amendments thereto, the Regional Water Board may revise or modify this Order in accordance with the more stringent standards.

## **VI. PROVISIONS**

### **A. Standard Provisions**

1. The Discharger shall comply with all “Standard Provisions” in Attachment D.
2. The Discharger shall comply with all applicable provisions of the “Regional Standard Provisions, and Monitoring and Reporting Requirements for NPDES Wastewater Discharge Permits” (Attachment G).

### **B. Monitoring and Reporting**

The Discharger shall comply with the MRP (Attachment E) and future revisions thereto, and applicable sampling and reporting requirements in Attachments D and G.

### **C. Special Provisions**

#### **1. Reopener Provisions**

The Regional Water Board may modify or reopen this Order prior to its expiration date in any of the following circumstances as allowed by law:

- a. If present or future investigations demonstrate that the discharges governed by this Order have or will have a reasonable potential to cause or contribute to, or will cease to have, adverse impacts on water quality or beneficial uses of the receiving waters.
- b. If new or revised water quality objectives or total maximum daily loads (TMDLs) come into effect (whether statewide, regional, or site-specific). In such cases, effluent limitations in this Order may be modified as necessary to reflect the updated water quality objectives and wasteload allocations in the TMDLs. Adoption of the effluent limitations in this Order is not intended to restrict in any way future modifications based on legally-adopted water quality objectives or TMDLs or as otherwise permitted under federal regulations governing NPDES permit modifications.
- c. If translator, dilution, or other water quality studies provide a basis for determining that a permit condition should be modified.
- d. If State Water Board precedential decisions, new policies, new laws, or new regulations are adopted.
- e. If an administrative or judicial decision on a separate NPDES permit or WDRs addresses requirements similar to this discharge.
- f. If the Discharger requests adjustments in effluent limits due to the implementation of stormwater diversion pursuant to the Municipal Regional Stormwater Permit (Permit No. CAS612008) for redirecting dry weather and first flush discharges from the storm drain system to the sanitary sewer system as a stormwater pollutant control strategy.
- g. Or as otherwise authorized by law.

The Discharger may request a permit modification based on any of the circumstances above. With any such request, the Discharger shall include antidegradation and anti-backsliding analyses.

## 2. Effluent Characterization Study and Report

- a. Study Elements.** The Discharger shall continue to characterize and evaluate the discharge from the following discharge point to verify that the “no” or “unknown” reasonable potential analysis conclusions of this Order remain valid and to inform the next permit reissuance. The Discharger shall collect representative samples at the monitoring station set forth below, as defined in the MRP, at no less than the frequency specified below:

<u>Discharge Point</u>	<u>Monitoring Location</u>	<u>Minimum Frequency</u>
001	M-002D	Once

Samples shall be collected between November 1 and April 30. The samples shall be analyzed for the pollutants listed in Attachment G, Table C, except for those pollutants with effluent limitations where the MRP already requires more frequent monitoring and except for those pollutants for which there are no water quality criteria (see Fact Sheet Table F-5). The samples shall also be analyzed for total ammonia, temperature, and pH, except when the MRP already requires more frequent monitoring; these samples shall be collected concurrently. Compliance with this requirement shall be achieved in accordance with the specifications of Attachment G sections III.A.1 and III.A.2. Pretreatment program monitoring conducted at Monitoring Location M-002D in accordance with NPDES Permit No. CA0037869 (for the EBDA common outfall) may be used to satisfy relevant parts of these sampling requirements.

The Discharger shall evaluate whether concentrations of any of these pollutants significantly increase over past performance. The Discharger shall investigate the cause of any such increase. The investigation may include, but need not be limited to, an increase in monitoring frequency, monitoring of internal process streams, and monitoring of influent sources. The Discharger shall establish remedial measures addressing any increase resulting in reasonable potential to cause or contribute to an excursion above applicable water quality objectives. This requirement may be satisfied through identification of the constituent as a “pollutant of concern” in the Discharger’s Pollutant Minimization Program, required by Provision VI.C.4 and NPDES Permit No. CA0037869.

### b. Reporting Requirements

- i. Routine Reporting.** The Discharger shall, after receipt of analytical results, report the following in the transmittal letter for the next annual self-monitoring report:
- (a) Indication that a sample for this study was collected; and
  - (b) Identity of pollutants detected at or above applicable water quality criteria (see Fact Sheet Table F-5) and the detected concentrations of those pollutants.

- ii. **Final Report.** The Discharger shall submit a final report that presents all these data with the application for permit reissuance.

### 3. Receiving Water Characterization Study and Report

- a. **Study Elements.** The Discharger shall characterize and evaluate the receiving water at the following discharge points to verify that the “no” or “unknown” reasonable potential analysis conclusions of this Order remain valid and to inform the next permit reissuance. The Discharger shall collect representative samples at the monitoring station set forth below, as defined in the MRP, at no less than the frequency specified below:

<u>Monitoring Location</u>	<u>Minimum Frequency</u>
RSW-002	Once

Samples shall be collected between November 1 and April 30. The samples shall be analyzed for the pollutants listed in Attachment G, Table C, except for those pollutants for which there are no water quality criteria (see Fact Sheet Table F-5). Compliance with this requirement shall be achieved in accordance with the specifications of Attachment G sections III.A.1 and III.A.2.

#### b. Reporting Requirements

- i. **Routine Reporting.** The Discharger shall, after receipt of analytical results, report the following in the transmittal letter for the next annual self-monitoring report:
  - (a) Indication that a sample for this study was collected; and
  - (b) Identity of pollutants detected at or above applicable water quality criteria (see Fact Sheet Table F-5) and the detected concentrations of those pollutants.
- ii. **Final Report.** The Discharger shall submit a final report that presents all these data with the application for permit reissuance.

### 4. Pollutant Minimization Program

- a. The Discharger shall develop and conduct a Pollutant Minimization Program as further described below when there is evidence that a priority pollutant is present in the effluent above an effluent limitation (e.g., sample results reported as detected but not quantified [DNQ] when the effluent limitation is less than the method detection limit [MDL], sample results from analytical methods more sensitive than those methods required by this Order, presence of whole effluent toxicity, health advisories for fish consumption, or results of benthic or aquatic organism tissue sampling) and either:
  - i. A sample result is reported as DNQ and the effluent limitation is less than the Reporting Level (RL); or
  - ii. A sample result is reported as not detected (ND) and the effluent limitation is less than the MDL, using definitions in Attachment A and reporting protocols described in the MRP.



- b.** If triggered by the reasons set forth in Provision VI.C.4.a, above, the Discharger's Pollutant Minimization Program shall include, but not be limited to, the following actions and submittals:
- i.** Annual review and semi-annual monitoring of potential sources of the reportable priority pollutants, which may include fish tissue monitoring and other bio-uptake sampling, or alternative measures when source monitoring is unlikely to produce useful analytical data;
  - ii.** Quarterly monitoring for the reportable priority pollutants in the influent to the Facility. The Executive Officer may approve alternative measures when influent monitoring is unlikely to produce useful analytical data;
  - iii.** Submittal of a control strategy designed to proceed toward the goal of maintaining concentrations of the reportable priority pollutants in the effluent at or below the effluent limitation;
  - iv.** Implementation of appropriate cost-effective control measures for the reportable priority pollutants, consistent with the control strategy; and
  - v.** Inclusion of the following specific items within the annual report required by Provision VI.C.4.b above:
    - (a)** All Pollutant Minimization Program monitoring results for the previous year;
    - (b)** List of potential sources of the reportable priority pollutants;
    - (c)** Summary of all actions undertaken pursuant to the control strategy; and
    - (d)** Description of actions to be taken in the following year.

## **ATTACHMENT A – DEFINITIONS**

### **Arithmetic Mean ( $\mu$ )**

Also called the average, the sum of measured values divided by the number of samples. For ambient water concentrations, the arithmetic mean is calculated as follows:

$$\text{Arithmetic mean} = \mu = \Sigma x / n \quad \text{where: } \Sigma x \text{ is the sum of the measured ambient water concentrations, and } n \text{ is the number of samples.}$$

### **Average Monthly Effluent Limitation (AMEL)**

The highest allowable average of daily discharges over a calendar month, calculated as the sum of all daily discharges measured during a calendar month divided by the number of daily discharges measured during that month.

### **Average Weekly Effluent Limitation (AWEL)**

The highest allowable average of daily discharges over a calendar week (Sunday through Saturday), calculated as the sum of all daily discharges measured during a calendar week divided by the number of daily discharges measured during that week.

### **Bioaccumulative**

Taken up by an organism from its surrounding medium through gill membranes, epithelial tissue, or from food and subsequently concentrated and retained in the body of the organism.

### **Carcinogenic**

Known to cause cancer in living organisms.

### **Coefficient of Variation**

Measure of data variability calculated as the estimated standard deviation divided by the arithmetic mean of the observed values.

### **Daily Discharge**

Either: (1) the total mass of the constituent discharged over the calendar day (12:00 am through 11:59 pm) or any 24-hour period that reasonably represents a calendar day for purposes of sampling (as specified in the permit) for a constituent with limitations expressed in units of mass; or (2) the unweighted arithmetic mean measurement of the constituent over the day for a constituent with limitations expressed in other units of measurement (e.g., concentration).

The daily discharge may be determined by the analytical results of a composite sample taken over the course of one day (a calendar day or other 24-hour period defined as a day) or by the arithmetic mean of analytical results from one or more grab samples taken over the course of the day.

For composite sampling, if 1 day is defined as a 24-hour period other than a calendar day, the analytical result for the 24-hour period is considered the result for the calendar day in which the 24-hour period ends.

**Detected, but Not Quantified (DNQ)**

Sample result less than the RL, but greater than or equal to the laboratory's MDL. Sample results reported as DNQ are estimated concentrations.

**Dilution Credit**

Amount of dilution granted to a discharge in the calculation of a water quality-based effluent limitation, based on the allowance of a specified mixing zone. It is calculated from the dilution ratio or determined by conducting a mixing zone study or modeling the discharge and receiving water.

**Effluent Concentration Allowance (ECA)**

Value derived from the water quality criterion/objective, dilution credit, and ambient background concentration that is used, in conjunction with the CV for the effluent monitoring data, to calculate a long-term average (LTA) discharge concentration. The ECA has the same meaning as waste load allocation (WLA) as used in U.S. EPA guidance (*Technical Support Document For Water Quality-based Toxics Control*, March 1991, second printing, EPA/505/2-90-001).

**Enclosed Bay**

Indentation along the coast that encloses an area of oceanic water within a distinct headlands or harbor works. Enclosed bays include all bays where the narrowest distance between the headlands or outermost harbor works is less than 75 percent of the greatest dimension of the enclosed portion of the bay. Enclosed bays include, but are not limited to, Humboldt Bay, Bodega Harbor, Tomales Bay, Drake's Estero, San Francisco Bay, Morro Bay, Los Angeles-Long Beach Harbor, Upper and Lower Newport Bay, Mission Bay, and San Diego Bay. Enclosed bays do not include inland surface waters or ocean waters.

**Estimated Chemical Concentration**

Concentration that results from the confirmed detection of the substance below the ML value by the analytical method.

**Estuaries**

Waters, including coastal lagoons, located at the mouths of streams that serve as areas of mixing for fresh and ocean waters. Coastal lagoons and mouths of streams that are temporarily separated from the ocean by sandbars are considered estuaries. Estuarine waters are considered to extend from a bay or the open ocean to a point upstream where there is no significant mixing of fresh water and seawater. Estuarine waters include, but are not limited to, the Sacramento-San Joaquin Delta, as defined in Water Code section 12220, Suisun Bay, Carquinez Strait downstream to the Carquinez Bridge, and appropriate areas of the Smith, Mad, Eel, Noyo, Russian, Klamath, San Diego, and Otay rivers. Estuaries do not include inland surface waters or ocean waters.

**Inland Surface Waters**

All surface waters of the state that do not include the ocean, enclosed bays, or estuaries.

**Instantaneous Maximum Effluent Limitation**

Highest allowable value for any single grab sample or aliquot (i.e., each grab sample or aliquot is independently compared to the instantaneous maximum limitation).

**Instantaneous Minimum Effluent Limitation**

Lowest allowable value for any single grab sample or aliquot (i.e., each grab sample or aliquot is independently compared to the instantaneous minimum limitation).

**Maximum Daily Effluent Limitation (MDEL)**

Highest allowable daily discharge of a pollutant, over a calendar day (or 24-hour period). For pollutants with limitations expressed in units of mass, the daily discharge is calculated as the total mass of the pollutant discharged over the day. For pollutants with limitations expressed in other units of measurement, the daily discharge is calculated as the arithmetic mean measurement of the pollutant over the day.

**Median**

Middle measurement in a set of data. The median of a set of data is found by first arranging the measurements in order of magnitude (either increasing or decreasing order). If the number of measurements (n) is odd, then the median =  $X_{(n+1)/2}$ . If n is even, then the median =  $(X_{n/2} + X_{(n/2)+1})/2$  (i.e., the midpoint between n/2 and n/2+1).

**Method Detection Limit (MDL)**

Minimum concentration of a substance that can be measured and reported with 99 percent confidence that the analyte concentration is greater than zero, as defined in 40 C.F.R. part 136, Attachment B, revised as of July 3, 1999.

**Minimum Level (ML)**

Concentration at which the entire analytical system gives a recognizable signal and acceptable calibration point. The ML is the concentration in a sample that is equivalent to the concentration of the lowest calibration standard analyzed by a specific analytical procedure, assuming that all the method specified sample weights, volumes, and processing steps have been followed.

**Mixing Zone**

Limited volume of receiving water allocated for mixing with a wastewater discharge where water quality criteria can be exceeded without causing adverse effects to the overall water body.

**Not Detected (ND)**

Sample results less than the laboratory's MDL.

**Persistent Pollutants**

Substances for which degradation or decomposition in the environment is nonexistent or very slow.

**Pollutant Minimization Program**

Program of waste minimization and pollution prevention actions that include, but are not limited to, product substitution, waste stream recycling, alternative waste management methods, and education of the public and businesses. The goal of the Pollutant Minimization Program is to reduce all potential sources of a priority pollutant through pollutant minimization (control) strategies, including pollution prevention measures as appropriate, to maintain the effluent concentration at or below the water quality-based effluent limitation. Pollution prevention measures may be particularly appropriate for persistent bioaccumulative priority pollutants where there is evidence that beneficial uses are being impacted. Cost effectiveness may be considered when establishing the requirements of a Pollutant Minimization Program. The completion and implementation of a Pollution Prevention Plan, if required pursuant to Water Code section 13263.3(d), is considered to fulfill Pollutant Minimization Program requirements.

### **Pollution Prevention**

Any action that causes a net reduction in the use or generation of a hazardous substance or other pollutant that is discharged into water and includes, but is not limited to, input change, operational improvement, production process change, and product reformulation (as defined in Water Code section 13263.3). Pollution prevention does not include actions that merely shift a pollutant in wastewater from one environmental medium to another environmental medium, unless clear environmental benefits of such an approach are identified to the satisfaction of the State Water Board or Regional Water Board.

### **Reporting Level (RL)**

ML (and its associated analytical method) chosen by the Discharger for reporting and compliance determination from the MLs included in this Order, including an additional factor if applicable as discussed herein. The MLs included in this Order correspond to approved analytical methods for reporting a sample result that are selected by the Regional Water Board either from SIP Appendix 4 in accordance with SIP section 2.4.2 or established in accordance with SIP section 2.4.3. The ML is based on the proper application of method-based analytical procedures for sample preparation and the absence of any matrix interferences. Other factors may be applied to the ML depending on the specific sample preparation steps employed. For example, the treatment typically applied in cases where there are matrix-effects is to dilute the sample or sample aliquot by a factor of ten. In such cases, this additional factor must be applied to the ML in the computation of the RL.

### **Source of Drinking Water**

Any water designated as having a municipal or domestic supply (MUN) beneficial use.

### **Standard Deviation ( $\sigma$ )**

Measure of variability calculated as follows:

$$\sigma = \left( \frac{\sum[(x - \mu)^2]}{(n - 1)} \right)^{0.5}$$

where:

x is the observed value;

$\mu$  is the arithmetic mean of the observed values; and

n is the number of samples.

### **Toxicity Reduction Evaluation (TRE)**

Study conducted in a step-wise process designed to identify the causative agents of effluent or ambient toxicity, isolate the sources of toxicity, evaluate the effectiveness of toxicity control options, and then confirm the reduction in toxicity. The first steps of the TRE consist of the collection of data relevant to the toxicity, including additional toxicity testing, and an evaluation of facility operations and maintenance practices, and best management practices. A Toxicity Identification Evaluation (TIE) may be required as part of the TRE, if appropriate. A TIE is a set of procedures to identify the specific chemicals responsible for toxicity. These procedures are performed in three phases (characterization, identification, and confirmation) using aquatic organism toxicity tests.

### ATTACHMENT B – FACILITY MAP

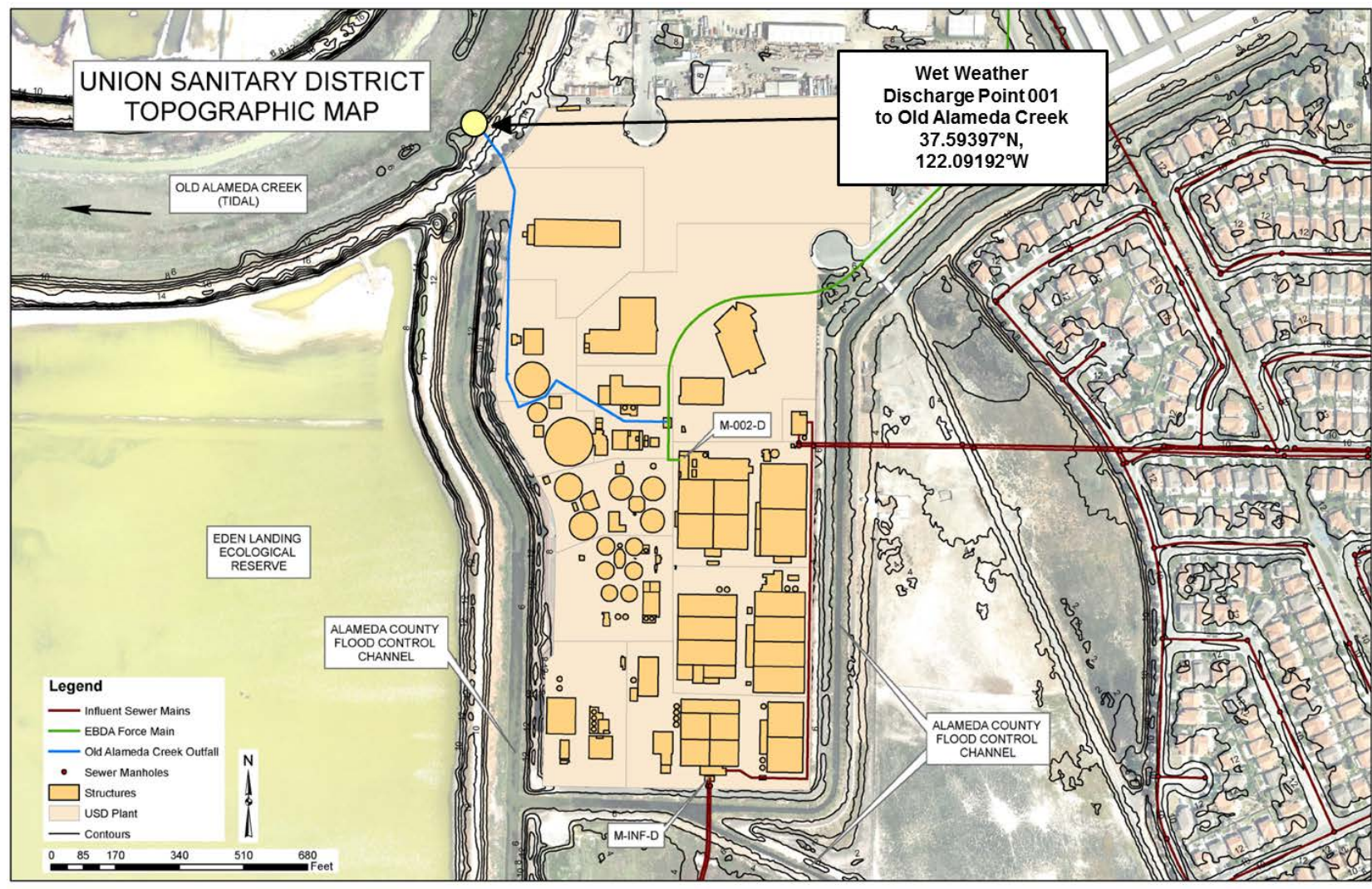

**ATTACHMENT C – PROCESS FLOW DIAGRAM**

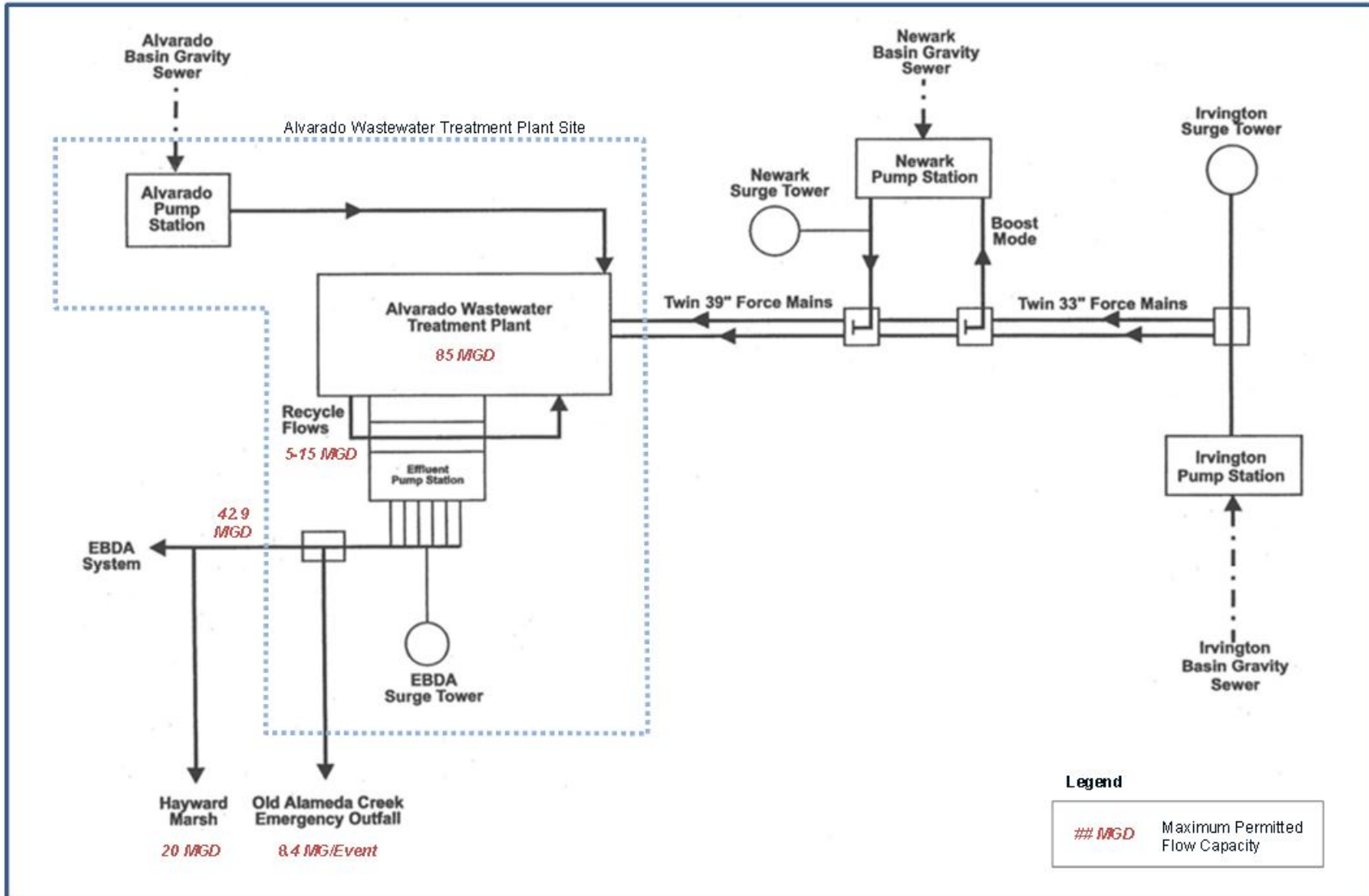

## **ATTACHMENT D –STANDARD PROVISIONS**

### **I. STANDARD PROVISIONS – PERMIT COMPLIANCE**

#### **A. Duty to Comply**

1. The Discharger must comply with all of the terms, requirements, and conditions of this Order. Any noncompliance constitutes a violation of the Clean Water Act (CWA) and the California Water Code and is grounds for enforcement action; permit termination, revocation and reissuance, or modification; denial of a permit renewal application; or a combination thereof. (40 C.F.R. § 122.41(a); Wat. Code §§ 13261, 13263, 13265, 13268, 13000, 13001, 13304, 13350, 13385.)
2. The Discharger shall comply with effluent standards or prohibitions established under CWA section 307(a) for toxic pollutants and with standards for sewage sludge use or disposal established under CWA section 405(d) within the time provided in the regulations that establish these standards or prohibitions, even if this Order has not yet been modified to incorporate the requirement. (40 C.F.R. § 122.41(a)(1).)

#### **B. Need to Halt or Reduce Activity Not a Defense**

It shall not be a defense for a Discharger in an enforcement action that it would have been necessary to halt or reduce the permitted activity in order to maintain compliance with the conditions of this Order. (40 C.F.R. § 122.41(c).)

#### **C. Duty to Mitigate**

The Discharger shall take all reasonable steps to minimize or prevent any discharge or sludge use or disposal in violation of this Order that has a reasonable likelihood of adversely affecting human health or the environment. (40 C.F.R. § 122.41(d).)

#### **D. Proper Operation and Maintenance**

The Discharger shall at all times properly operate and maintain all facilities and systems of treatment and control (and related appurtenances) which are installed or used by the Discharger to achieve compliance with the conditions of this Order. Proper operation and maintenance also includes adequate laboratory controls and appropriate quality assurance procedures. This provision requires the operation of backup or auxiliary facilities or similar systems that are installed by a Discharger only when necessary to achieve compliance with the conditions of this Order. (40 C.F.R. § 122.41(e).)

#### **E. Property Rights**

1. This Order does not convey any property rights of any sort or any exclusive privileges. (40 C.F.R. § 122.41(g).)
2. The issuance of this Order does not authorize any injury to persons or property or invasion of other private rights, or any infringement of state or local law or regulations. (40 C.F.R. § 122.5(c).)



## F. Inspection and Entry

The Discharger shall allow the Regional Water Board, State Water Board, U.S. EPA, and/or their authorized representatives (including an authorized contractor acting as their representative), upon the presentation of credentials and other documents, as may be required by law, to (33 U.S.C. § 1318(a)(4)(B); 40 C.F.R. § 122.41(i); Wat. Code, §§ 13267, 13383):

1. Enter upon the Discharger's premises where a regulated facility or activity is located or conducted, or where records are kept under the conditions of this Order (33 U.S.C. § 1318(a)(4)(B)(i); 40 C.F.R. § 122.41(i)(1); Wat. Code, §§ 13267, 13383);
2. Have access to and copy, at reasonable times, any records that must be kept under the conditions of this Order (33 U.S.C. § 1318(a)(4)(B)(ii); 40 C.F.R. § 122.41(i)(2)); Wat. Code, §§ 13267, 13383);
3. Inspect and photograph, at reasonable times, any facilities, equipment (including monitoring and control equipment), practices, or operations regulated or required under this Order (33 U.S.C. § 1318(a)(4)(B)(ii); 40 C.F.R. § 122.41(i)(3); Wat. Code, §§ 13267, 13383); and
4. Sample or monitor, at reasonable times, for the purposes of ensuring Order compliance or as otherwise authorized by the CWA or the Water Code, any substances or parameters at any location. (33 U.S.C. § 1318(a)(4)(B); 40 C.F.R. § 122.41(i)(4); Wat. Code, §§ 13267, 13383.)

## G. Bypass

### 1. Definitions

- a. "Bypass" means the intentional diversion of waste streams from any portion of a treatment facility. (40 C.F.R. § 122.41(m)(1)(i).)
- b. "Severe property damage" means substantial physical damage to property, damage to the treatment facilities, which causes them to become inoperable, or substantial and permanent loss of natural resources that can reasonably be expected to occur in the absence of a bypass. Severe property damage does not mean economic loss caused by delays in production. (40 C.F.R. § 122.41(m)(1)(ii).)

2. **Bypass not exceeding limitations.** The Discharger may allow any bypass to occur which does not cause exceedances of effluent limitations, but only if it is for essential maintenance to assure efficient operation. These bypasses are not subject to the provisions listed in Standard Provisions – Permit Compliance I.G.3, I.G.4, and I.G.5 below. (40 C.F.R. § 122.41(m)(2).)
3. **Prohibition of bypass.** Bypass is prohibited, and the Regional Water Board may take enforcement action against a Discharger for bypass, unless (40 C.F.R. § 122.41(m)(4)(i)):
  - a. Bypass was unavoidable to prevent loss of life, personal injury, or severe property damage (40 C.F.R. § 122.41(m)(4)(i)(A));

- b. There were no feasible alternatives to the bypass, such as the use of auxiliary treatment facilities, retention of untreated wastes, or maintenance during normal periods of equipment downtime. This condition is not satisfied if adequate back-up equipment should have been installed in the exercise of reasonable engineering judgment to prevent a bypass that occurred during normal periods of equipment downtime or preventive maintenance (40 C.F.R. § 122.41(m)(4)(i)(B)); and
  - c. The Discharger submitted notice to the Regional Water Board as required under Standard Provisions – Permit Compliance I.G.5 below. (40 C.F.R. § 122.41(m)(4)(i)(C).)
4. **Approval.** The Regional Water Board may approve an anticipated bypass, after considering its adverse effects, if the Regional Water Board determines that it will meet the three conditions listed in Standard Provisions—Permit Compliance I.G.3 above. (40 C.F.R. § 122.41(m)(4)(ii).)

#### 5. Notice

- a. **Anticipated bypass.** If the Discharger knows in advance of the need for a bypass, it shall submit a notice, if possible at least 10 days before the date of the bypass. (40 C.F.R. § 122.41(m)(3)(i).)
- b. **Unanticipated bypass.** The Discharger shall submit notice of an unanticipated bypass as required in Standard Provisions - Reporting V.E below (24-hour notice). (40 C.F.R. § 122.41(m)(3)(ii).)

#### H. Upset

Upset means an exceptional incident in which there is unintentional and temporary noncompliance with technology based permit effluent limitations because of factors beyond the reasonable control of the Discharger. An upset does not include noncompliance to the extent caused by operational error, improperly designed treatment facilities, inadequate treatment facilities, lack of preventive maintenance, or careless or improper operation. (40 C.F.R. § 122.41(n)(1).)

- 1. **Effect of an upset.** An upset constitutes an affirmative defense to an action brought for noncompliance with such technology based permit effluent limitations if the requirements of Standard Provisions – Permit Compliance I.H.2 below are met. No determination made during administrative review of claims that noncompliance was caused by upset, and before an action for noncompliance, is final administrative action subject to judicial review. (40 C.F.R. § 122.41(n)(2).)
- 2. **Conditions necessary for a demonstration of upset.** A Discharger who wishes to establish the affirmative defense of upset shall demonstrate, through properly signed, contemporaneous operating logs or other relevant evidence that (40 C.F.R. § 122.41(n)(3)):
  - a. An upset occurred and that the Discharger can identify the cause(s) of the upset (40 C.F.R. § 122.41(n)(3)(i));
  - b. The permitted facility was, at the time, being properly operated (40 C.F.R. § 122.41(n)(3)(ii));

- c. The Discharger submitted notice of the upset as required in Standard Provisions—Reporting V.E.2.b below (24-hour notice) (40 C.F.R. § 122.41(n)(3)(iii)); and
  - d. The Discharger complied with any remedial measures required under Standard Provisions—Permit Compliance I.C above. (40 C.F.R. § 122.41(n)(3)(iv).)
3. **Burden of proof.** In any enforcement proceeding, the Discharger seeking to establish the occurrence of an upset has the burden of proof. (40 C.F.R. § 122.41(n)(4).)

## II. STANDARD PROVISIONS—PERMIT ACTION

### A. General

This Order may be modified, revoked and reissued, or terminated for cause. The filing of a request by the Discharger for modification, revocation and reissuance, or termination, or a notification of planned changes or anticipated noncompliance does not stay any Order condition. (40 C.F.R. § 122.41(f).)

### B. Duty to Reapply

If the Discharger wishes to continue an activity regulated by this Order after the expiration date of this Order, the Discharger must apply for and obtain a new permit. (40 C.F.R. § 122.41(b).)

### C. Transfers

This Order is not transferable to any person except after notice to the Regional Water Board. The Regional Water Board may require modification or revocation and reissuance of the Order to change the name of the Discharger and incorporate such other requirements as may be necessary under the CWA and the Water Code. (40 C.F.R. §§ 122.41(l)(3), 122.61.)

## III. STANDARD PROVISIONS – MONITORING

- A. Samples and measurements taken for the purpose of monitoring shall be representative of the monitored activity. (40 C.F.R. § 122.41(j)(1).)
- B. Monitoring must be conducted according to test procedures approved under 40 C.F.R. part 136 for the analyses of pollutants unless another method is required under 40 C.F.R. subchapters N or O. Monitoring must be conducted according to sufficiently sensitive test methods approved under 40 C.F.R. part 136 for the analysis of pollutants or pollutant parameters or required under 40 C.F.R. chapter 1, subchapter N or O. For the purposes of this paragraph, a method is sufficiently sensitive when:
  - 1. The method minimum level (ML) is at or below the level of the effluent limitation established in the permit for the measured pollutant or pollutant parameter, and either the method ML is at or below the level of the applicable water quality criterion for the measured pollutant or pollutant parameter or the method ML is above the applicable water quality criterion but the amount of the pollutant or pollutant parameter in a facility's discharge is high enough that the method detects and quantifies the level of the pollutant or pollutant parameter in the discharge; or

2. The method has the lowest ML of the analytical methods approved under 40 C.F.R. part 136 or required under 40 C.F.R. chapter 1, subchapter N or O for the measured pollutant or pollutant parameter.

In the case of pollutants for which there are no approved methods under 40 C.F.R. part 136 or otherwise required under 40 C.F.R. subchapters N or O, monitoring must be conducted according to a test procedure specified in this Order for such pollutants. (40 C.F.R. §§ 122.21(e)(3), 122.41(j)(4), 122.44(i)(1)(iv).)

#### **IV. STANDARD PROVISIONS—RECORDS**

- A. Except for records of monitoring information required by this Order related to the Discharger's sewage sludge use and disposal activities, which shall be retained for a period of at least five years (or longer as required by 40 C.F.R. part 503), the Discharger shall retain records of all monitoring information, including all calibration and maintenance records and all original strip chart recordings for continuous monitoring instrumentation, copies of all reports required by this Order, and records of all data used to complete the application for this Order, for a period of at least three (3) years from the date of the sample, measurement, report or application. This period may be extended by request of the Regional Water Board Executive Officer at any time. (40 C.F.R. § 122.41(j)(2).)
- B. Records of monitoring information shall include the following:
  1. The date, exact place, and time of sampling or measurements (40 C.F.R. § 122.41(j)(3)(i));
  2. The individual(s) who performed the sampling or measurements (40 C.F.R. § 122.41(j)(3)(ii));
  3. The date(s) the analyses were performed (40 C.F.R. § 122.41(j)(3)(iii));
  4. The individual(s) who performed the analyses (40 C.F.R. § 122.41(j)(3)(iv));
  5. The analytical techniques or methods used (40 C.F.R. § 122.41(j)(3)(v)); and
  6. The results of such analyses. (40 C.F.R. § 122.41(j)(3)(vi).)
- C. Claims of confidentiality for the following information will be denied (40 C.F.R. § 122.7(b)):
  1. The name and address of any permit applicant or Discharger (40 C.F.R. § 122.7(b)(1)); and
  2. Permit applications and attachments, permits, and effluent data. (40 C.F.R. § 122.7(b)(2).)

#### **V. STANDARD PROVISIONS—REPORTING**

##### **A. Duty to Provide Information**

The Discharger shall furnish to the Regional Water Board, State Water Board, or U.S. EPA within a reasonable time, any information which the Regional Water Board, State Water Board, or U.S. EPA may request to determine whether cause exists for modifying, revoking and reissuing, or terminating this Order or to determine compliance with this Order. Upon request, the Discharger shall also furnish to the Regional Water Board, State Water Board, or U.S. EPA copies of records required to be kept by this Order. (40 C.F.R. § 122.41(h); Wat. Code, §§ 13267, 13383.)

## **B. Signatory and Certification Requirements**

- 1.** All applications, reports, or information submitted to the Regional Water Board, State Water Board, and/or U.S. EPA shall be signed and certified in accordance with Standard Provisions—Reporting V.B.2, V.B.3, V.B.4, and V.B.5 below. (40 C.F.R. § 122.41(k).)
- 2.** For a corporation, all permit applications shall be signed by a responsible corporate officer. For the purpose of this section, a responsible corporate officer means: (i) a president, secretary, treasurer, or vice-president of the corporation in charge of a principal business function, or any other person who performs similar policy- or decision-making functions for the corporation, or (ii) the manager of one or more manufacturing, production, or operating facilities, provided, the manager is authorized to make management decisions which govern the operation of the regulated facility including having the explicit or implicit duty of making major capital investment recommendations, and initiating and directing other comprehensive measures to assure long term environmental compliance with environmental laws and regulations; the manager can ensure that the necessary systems are established or actions taken to gather complete and accurate information for permit application requirements; and where authority to sign documents has been assigned or delegated to the manager in accordance with corporate procedures. (40 C.F.R. § 122.22(a)(1).)

For a partnership or sole proprietorship, all permit applications shall be signed by a general partner or the proprietor, respectively. (40 C.F.R. § 122.22(a)(2).)

For a municipality, state, federal, or other public agency, all permit applications shall be signed by either a principal executive officer or ranking elected official. For purposes of this provision, a principal executive officer of a federal agency includes (i) the chief executive officer of the agency, or (ii) a senior executive officer having responsibility for the overall operations of a principal geographic unit of the agency (e.g., Regional Administrators of U.S. EPA). (40 C.F.R. § 122.22(a)(3).)

- 3.** All reports required by this Order and other information requested by the Regional Water Board, State Water Board, or U.S. EPA shall be signed by a person described in Standard Provisions – Reporting V.B.2 above, or by a duly authorized representative of that person. A person is a duly authorized representative only if:
  - a.** The authorization is made in writing by a person described in Standard Provisions—Reporting V.B.2 above (40 C.F.R. § 122.22(b)(1));
  - b.** The authorization specifies either an individual or a position having responsibility for the overall operation of the regulated facility or activity such as the position of plant manager, operator of a well or a well field, superintendent, position of equivalent responsibility, or an individual or position having overall responsibility for environmental matters for the company. (A duly authorized representative may thus be either a named individual or any individual occupying a named position.) (40 C.F.R. § 122.22(b)(2)); and
  - c.** The written authorization is submitted to the Regional Water Board and State Water Board. (40 C.F.R. § 122.22(b)(3).)

4. If an authorization under Standard Provisions – Reporting V.B.3 above is no longer accurate because a different individual or position has responsibility for the overall operation of the facility, a new authorization satisfying the requirements of Standard Provisions—Reporting V.B.3 above must be submitted to the Regional Water Board and State Water Board prior to or together with any reports, information, or applications, to be signed by an authorized representative. (40 C.F.R. § 122.22(c).)
5. Any person signing a document under Standard Provisions—Reporting V.B.2 or V.B.3 above shall make the following certification:

“I certify under penalty of law that this document and all attachments were prepared under my direction or supervision in accordance with a system designed to assure that qualified personnel properly gather and evaluate the information submitted. Based on my inquiry of the person or persons who manage the system or those persons directly responsible for gathering the information, the information submitted is, to the best of my knowledge and belief, true, accurate, and complete. I am aware that there are significant penalties for submitting false information, including the possibility of fine and imprisonment for knowing violations.” (40 C.F.R. § 122.22(d).)

### **C. Monitoring Reports**

1. Monitoring results shall be reported at the intervals specified in the Monitoring and Reporting Program in this Order. (40 C.F.R. § 122.22(l)(4).)
2. Monitoring results must be reported on a Discharge Monitoring Report (DMR) form or forms provided or specified by the Regional Water Board or State Water Board for reporting results of monitoring of sludge use or disposal practices. (40 C.F.R. § 122.41(l)(4)(i).)
3. If the Discharger monitors any pollutant more frequently than required by this Order using test procedures approved under 40 C.F.R. part 136, or another method required for an industry-specific waste stream under 40 C.F.R. subchapters N or O, the results of such monitoring shall be included in the calculation and reporting of the data submitted in the DMR or sludge reporting form specified by the Regional Water Board. (40 C.F.R. § 122.41(l)(4)(ii).)
4. Calculations for all limitations, which require averaging of measurements, shall utilize an arithmetic mean unless otherwise specified in this Order. (40 C.F.R. § 122.41(l)(4)(iii).)

### **D. Compliance Schedules**

Reports of compliance or noncompliance with, or any progress reports on, interim and final requirements contained in any compliance schedule of this Order, shall be submitted no later than 14 days following each schedule date. (40 C.F.R. § 122.41(l)(5).)

### **E. Twenty-Four Hour Reporting**

1. The Discharger shall report any noncompliance that may endanger health or the environment. Any information shall be provided orally within 24 hours from the time the Discharger becomes aware of the circumstances. A written submission shall also be provided within five (5) days of the time the Discharger becomes aware of the circumstances. The written

submission shall contain a description of the noncompliance and its cause; the period of noncompliance, including exact dates and times, and if the noncompliance has not been corrected, the anticipated time it is expected to continue; and steps taken or planned to reduce, eliminate, and prevent reoccurrence of the noncompliance. (40 C.F.R. § 122.41(l)(6)(i).)

2. The following shall be included as information that must be reported within 24 hours under this paragraph (40 C.F.R. § 122.41(l)(6)(ii)):
  - a. Any unanticipated bypass that exceeds any effluent limitation in this Order. (40 C.F.R. § 122.41(l)(6)(ii)(A).)
  - b. Any upset that exceeds any effluent limitation in this Order. (40 C.F.R. § 122.41(l)(6)(ii)(B).)
3. The Regional Water Board may waive the above-required written report under this provision on a case-by-case basis if an oral report has been received within 24 hours. (40 C.F.R. § 122.41(l)(6)(iii).)

#### **F. Planned Changes**

The Discharger shall give notice to the Regional Water Board as soon as possible of any planned physical alterations or additions to the permitted facility. Notice is required under this provision only when (40 C.F.R. § 122.41(l)(1)):

1. The alteration or addition to a permitted facility may meet one of the criteria for determining whether a facility is a new source in 40 C.F.R. section 122.29(b) (40 C.F.R. § 122.41(l)(1)(i)); or
2. The alteration or addition could significantly change the nature or increase the quantity of pollutants discharged. This notification applies to pollutants that are not subject to effluent limitations in this Order. (Alternatively, for an existing manufacturing, commercial, mining, or silvicultural discharge as referenced in 40 C.F.R. section 122.42(a), this notification applies to pollutants that are subject neither to effluent limitations in this Order nor to notification requirements under 40 C.F.R. section 122.42(a)(1) (see Additional Provisions—Notification Levels VII.A.1).) (40 C.F.R. § 122.41(l)(1)(ii).)
3. The alteration or addition results in a significant change in the Discharger's sludge use or disposal practices, and such alteration, addition, or change may justify the application of permit conditions that are different from or absent in the existing permit, including notification of additional use or disposal sites not reported during the permit application process or not reported pursuant to an approved land application plan. (40 C.F.R. § 122.41(l)(1)(iii).)

#### **G. Anticipated Noncompliance**

The Discharger shall give advance notice to the Regional Water Board or State Water Board of any planned changes in the permitted facility or activity that may result in noncompliance with this Order's requirements. (40 C.F.R. § 122.41(l)(2).)

## **H. Other Noncompliance**

The Discharger shall report all instances of noncompliance not reported under Standard Provisions—Reporting V.C, V.D, and V.E above at the time monitoring reports are submitted. The reports shall contain the information listed in Standard Provision—Reporting V.E above. (40 C.F.R. § 122.41(1)(7).)

## **I. Other Information**

When the Discharger becomes aware that it failed to submit any relevant facts in a permit application, or submitted incorrect information in a permit application or in any report to the Regional Water Board, State Water Board, or U.S. EPA, the Discharger shall promptly submit such facts or information. (40 C.F.R. § 122.41(1)(8).)

## **VI. STANDARD PROVISIONS – ENFORCEMENT**

- A. The Regional Water Board is authorized to enforce the terms of this permit under several provisions of the Water Code, including, but not limited to, sections 13268, 13385, 13386, and 13387.

## **VII. ADDITIONAL PROVISIONS—NOTIFICATION LEVELS**

### **A. Publicly-Owned Treatment Works (POTWs)**

All POTWs shall provide adequate notice to the Regional Water Board of the following (40 C.F.R. § 122.42(b)):

1. Any new introduction of pollutants into the POTW from an indirect discharger that would be subject to CWA sections 301 or 306 if it were directly discharging those pollutants (40 C.F.R. § 122.42(b)(1)); and
2. Any substantial change in the volume or character of pollutants being introduced into that POTW by a source introducing pollutants into the POTW at the time of adoption of this Order. (40 C.F.R. § 122.42(b)(2).)
3. Adequate notice shall include information on the quality and quantity of effluent introduced into the POTW as well as any anticipated impact of the change on the quantity or quality of effluent to be discharged from the POTW. (40 C.F.R. § 122.42(b)(3).)



## ATTACHMENT E – MONITORING AND REPORTING PROGRAM (MRP)

### Contents

I.	General Monitoring Provisions.....	E-2
II.	Monitoring Locations.....	E-2
III.	Effluent Monitoring Requirements .....	E-3
	A. Wet Weather Discharges .....	E-3
	B. Discharge Flap Gate Exercise Discharges.....	E-3
IV.	Receiving Water Monitoring Requirements .....	E-4
V.	Reporting Requirements .....	E-4
	A. General Monitoring and Reporting Requirements .....	E-4
	B. Self-Monitoring Reports (SMRs).....	E-5
	C. Discharge Monitoring Reports (DMRs).....	E-7
VI.	Modifications to Attachment G .....	E-7

### Tables

Table E-1.	Monitoring Locations.....	E-2
Table E-2.	Effluent Monitoring—Wet Weather .....	E-3
Table E-3.	Effluent Monitoring—Discharge Flap Gate Exercises .....	E-4
Table E-4.	Receiving Water Monitoring .....	E-4
Table E-5.	CIWQS Reporting.....	E-5
Table E-6.	Monitoring Periods .....	E-6

**ATTACHMENT E – MONITORING AND REPORTING PROGRAM (MRP)**

Clean Water Act section 308 and 40 C.F.R. sections 122.41(h), 122.41(j)-(l), 122.44(i), and 122.48 require that all NPDES permits specify monitoring and reporting requirements. Water Code sections 13267 and 13383 also authorize the Regional Water Board to establish monitoring, inspection, entry, reporting, and recordkeeping requirements. This MRP establishes monitoring, reporting, and recordkeeping requirements that implement federal and State laws and regulations.

**I. GENERAL MONITORING PROVISIONS**

- A. The Discharger shall comply with this MRP. The Executive Officer may amend this MRP pursuant to 40 C.F.R. sections 122.62, 122.63, and 124.5. If any discrepancies exist between this MRP and the “Regional Standard Provisions, and Monitoring and Reporting Requirements (Supplement to Attachment D) for NPDES Wastewater Discharge Permits” (Attachment G), this MRP shall prevail.
- B. The Discharger shall conduct all monitoring in accordance with Attachment D, section III, as supplemented by Attachment G. Equivalent test methods must be more sensitive than those specified in 40 C.F.R. section 136 and must be specified in this permit.

**II. MONITORING LOCATIONS**

The Discharger shall establish the following monitoring locations to demonstrate compliance with the effluent limitations, discharge specifications, and other requirements in this Order:

**Table E-1. Monitoring Locations**

Monitoring Location Type	Monitoring Location Name	Monitoring Location Description
Effluent	M-002D	A point at the treatment plant where all phases of treatment are complete (except dechlorination) just prior to where the Discharger transfers its effluent to the East Bay Dischargers Authority (EBDA) pipeline.
Effluent	EFF-WW	A point where all phases of treatment are complete (including dechlorination) just prior to discharge through Discharge Point No. 001.
Receiving Water	RSW-001	A point downstream in Old Alameda Creek between Discharge Point No. 001 and the Alvarado Flood Control Pump Station outfall. (Formerly RW-001)
Receiving Water	RSW-002	A point in Old Alameda Creek at least 100 feet upstream of Discharge Point No. 001 or, if access is limited, at the first accessible point upstream. If no wastewater is present, the monitoring location may be the same as Monitoring Location RSW-001.

### III. EFFLUENT MONITORING REQUIREMENTS

#### A. Wet Weather Discharges

When discharging to Old Alameda Creek during wet weather, the Discharger shall monitor plant effluent at Monitoring Locations M-002D and EFF-WW as follows:

**Table E-2. Effluent Monitoring—Wet Weather**

Parameter	Units	Sample Type	Minimum Sampling Frequency
<b>Monitoring Location M-002D</b>			
Carbonaceous Biochemical Oxygen Demand (5-day @ 20°C) (CBOD <sub>5</sub> )	mg/L	C-24 <sup>[1]</sup>	1/Discharge
Total Suspended Solids (TSS)	mg/L	C-24 <sup>[1]</sup>	1/Discharge
Oil and Grease <sup>[3]</sup>	mg/L	Grab	1/Discharge
pH	standard units	Grab	1/Discharge <sup>[4]</sup>
Lead, Total	µg/L	C-24 <sup>[1]</sup>	1/Discharge
Fecal Coliform	MPN/100mL <sup>[2]</sup>	Grab	1/Discharge
Ammonia, Total	mg/L as N	C-24 <sup>[1]</sup>	1/Discharge <sup>[4]</sup>
Temperature	°C	Grab	1/Discharge <sup>[4]</sup>
<b>Monitoring Location EFF-WW</b>			
Total Residual Chlorine	mg/L	Grab	Once every two hours during discharge
Discharge Duration	hours and minutes	Continuous	1/Discharge
Discharge Volume	gallons	Continuous	Continuous/D or 1/Discharge

Unit Abbreviations:

- mg/L = milligrams per liter
- µg/L = micrograms per liter
- MPN/100 mL = most probable number per 100 milliliters
- mg/L as N = milligrams per liter as nitrogen
- °C = degrees Celsius
- Continuous/D = monitored continuously and reported daily
- C-24 = 24-hour composite
- Grab = grab sample
- 1/Discharge = once per discharge event

Footnotes:

- <sup>[1]</sup> If the discharge is expected to last less than 24 hours, the Discharger may take a grab sample or a composite sample by mechanically or manually compositing samples once every two hours for the discharge duration.
- <sup>[2]</sup> Results may be reported as Colony Forming Units (CFU)/100 mL if the laboratory method used provides results in CFU/100 mL.
- <sup>[3]</sup> Oil and grease sampling and analysis shall be conducted in accordance with U.S. EPA Method 1664A.
- <sup>[4]</sup> Ammonia, temperature, and pH sampling shall occur concurrently to allow for the calculation of the un-ionized ammonia fraction.

#### B. Discharge Flap Gate Exercise Discharges

When discharging to Old Alameda Creek during discharge flap gate exercises, the Discharger shall monitor plant effluent at Monitoring Locations M-002D and EFF-WW as follows:

**Table E-3. Effluent Monitoring—Discharge Flap Gate Exercises**

Parameter	Units	Sample Type	Minimum Sampling Frequency
<b>Monitoring Location M-002D</b>			
Fecal Coliform	MPN/100mL <sup>[1]</sup>	Grab	1/Discharge
<b>Monitoring Location EFF-WW</b>			
Total Residual Chlorine	mg/L	Grab	1/Discharge
Discharge Duration	hours and minutes	Continuous	1/Discharge
Discharge Volume	gallons	Continuous	1/Discharge

Unit Abbreviations:

mg/L = milligrams per liter  
 MPN/100 mL = most probable number per 100 milliliters  
 1/Discharge = once per discharge event

Footnotes:

<sup>[1]</sup> Results may be reported as Colony Forming Units (CFU)/100 mL if the laboratory method used provides results in CFU/100 mL.

**IV. RECEIVING WATER MONITORING REQUIREMENTS**

When discharging to Old Alameda Creek, the Discharger shall monitor receiving waters at Monitoring Location RSW-001 as set follows:

**Table E-4. Receiving Water Monitoring**

Parameter	Units	Sample Type	Minimum Sampling Frequency
Standard Observations	See Attachment G section III.C.1		1/Discharge
pH	standard units	Grab	Once <sup>[2]</sup>
Temperature	°C	Grab	Once <sup>[2]</sup>
Salinity	ppt	Grab	Once <sup>[2]</sup>
Ammonia, Total	mg/L as N	Grab	Once <sup>[2]</sup>
Hardness	mg/L as CaCO <sub>3</sub>	Grab	Once
Dissolved Oxygen	mg/L	Grab	Once

Abbreviations:

°C = degrees Celsius  
 ppt = parts per thousand  
 mg/L = milligrams per liter  
 mg/L as CaCO<sub>3</sub> = milligrams per liter as calcium carbonate  
 mg/L as N = milligrams per liter as nitrogen  
 1/Discharge = once per discharge event

Footnotes:

<sup>[1]</sup> Samples shall be collected when discharging (e.g., during discharge flap gate exercises).  
<sup>[2]</sup> Ammonia, pH, temperature, and salinity monitoring shall occur concurrently.

**V. REPORTING REQUIREMENTS**

**A. General Monitoring and Reporting Requirements**

The Discharger shall comply with all Standard Provisions (Attachments D and G) related to monitoring, reporting, and recordkeeping, with modifications shown in section VII, below.

**B. Self-Monitoring Reports (SMRs)**

1. **SMR Format.** The Discharger shall electronically submit SMRs using the State Water Board’s California Integrated Water Quality System (CIWQS) Web site ([http://www.waterboards.ca.gov/water\\_issues/programs/ciwqs](http://www.waterboards.ca.gov/water_issues/programs/ciwqs)). The CIWQS website will provide additional information for SMR submittal in the event of a planned service interruption for electronic submittal.
2. **SMR Due Dates and Contents.** The Discharger shall submit SMRs by the due dates, and with the contents, specified below:
  - a. **Annual SMR** — Annual SMRs shall be due June 15 each year, covering the previous calendar year. The annual SMR shall contain the items described in sections V.C.1.f of Attachment G. See Provision VI.C.2 (Effluent Characterization Study and Report) and Provision VI.C.3 (Receiving Water Characterization Study and Report) of this Order for information that must also be reported with the annual SMR.
  - b. **Specifications for Submitting SMRs to CIWQS** — The Discharger shall submit analytical results and other information using one of the methods in the table below:

**Table E-5. CIWQS Reporting**

Parameter	Method of Reporting	
	EDF/CDF data upload or manual entry	Attached File
All parameters identified in influent, effluent, and receiving water monitoring tables (except Dissolved Oxygen and Temperature)	Required for all results	
Dissolved Oxygen Temperature	Required for monthly maximum and minimum results only <sup>[1]</sup>	Discharger may use this method for all results or keep records
Antimony Arsenic Beryllium Cadmium Chromium Copper Cyanide Lead Mercury Nickel Selenium Silver Thallium Zinc Dioxins & Furans (by U.S. EPA Method 1613) Other Pollutants (by U.S. EPA methods 601, 602, 608, 610, 614, 624, and 625)	Required for all results <sup>[2]</sup>	
Volume and Duration of Wet Weather Discharge	Required for all wet weather effluent discharges	
Analytical Method	Not required (Discharger may select “data unavailable”) <sup>[1]</sup>	
Collection Time Analysis Time	Not required (Discharger may select “0:00”) <sup>[1]</sup>	

Footnotes:

<sup>[1]</sup> The Discharger shall continue to monitor at the minimum frequency specified in this MRP, keep records of the measurements, and make the records available upon request.

<sup>[2]</sup> These parameters require EDF/CDF data upload or manual entry regardless of whether monitoring is required by this MRP or other provisions of this Order (except for biosolids, sludge, or ash provisions).

The Discharger shall arrange all reported data in a tabular format and summarize data to clearly illustrate whether the Facility is operating in compliance with effluent limitations. The Discharger is not required to duplicate the submittal of data entered in a tabular format within CIWQS. When electronic submittal of data is required and CIWQS does not provide for entry into a tabular format, the Discharger shall electronically submit the data in a tabular format as an attachment.

**3. Monitoring Periods.** Monitoring periods for all required monitoring shall be as set forth below unless otherwise specified:

**Table E-6. Monitoring Periods**

Sampling Frequency	Monitoring Period Begins On...	Monitoring Period
Continuous	Order effective date	All times
Once every two hours	Order effective date	Once every two-hour period, beginning at midnight (e.g., 12:00 a.m. through 1:59 a.m.)
1/Discharge	First moment of discharge	Anytime during discharge event
Once	Order effective date	Once during Order term such that result is included with application for permit reissuance.

**4. RL and MDL Reporting.** The Discharger shall report with each sample result the Reporting Level (RL) and Method Detection Limit (MDL) as determined by the procedure in 40 C.F.R. part 136. The Discharger shall report the results of analytical determinations for the presence of chemical constituents in a sample using the following reporting protocols:

- a. Sample results greater than or equal to the RL shall be reported as measured by the laboratory (i.e., the measured chemical concentration in the sample).
- b. Sample results less than the RL, but greater than or equal to the laboratory’s MDL, shall be reported as “Detected, but Not Quantified,” or DNQ. The estimated chemical concentration of the sample shall also be reported.

For purposes of data collection, the laboratory shall write the estimated chemical concentration next to DNQ. The laboratory may, if such information is available, include numerical estimates of the data quality for the reported result. Numerical estimates of data quality may be percent accuracy (+/- a percentage of the reported value), numerical ranges (low to high), or any other means the laboratory considers appropriate.

- c. Sample results less than the laboratory’s MDL shall be reported as “Not Detected,” or ND.
- d. The Discharger shall instruct laboratories to establish calibration standards so that the minimum level (ML) value (or its equivalent if there is differential treatment of samples relative to calibration standards) is the lowest calibration standard. At no time is the Discharger to use analytical data derived from extrapolation beyond the lowest point of the calibration curve.

- 5. Compliance Determination.** Compliance with effluent limitations for priority pollutants shall be determined using sample reporting protocols defined above and in the Fact Sheet and Attachments A, D, and G. For purposes of reporting and administrative enforcement by the Regional Water Board and State Water Board, the Discharger shall be deemed out of compliance with effluent limitations if the concentration of the priority pollutant in the monitoring sample is greater than the effluent limitation and greater than or equal to the reporting level (RL).

### **C. Discharge Monitoring Reports (DMRs)**

The Discharger shall electronically certify and submit DMRs and SMRs using the Electronic Self-Monitoring Reports module eSMR 2.5 or any upgraded version. Electronic DMR submittal shall be in addition to electronic SMR submittal. Information about electronic DMR submittal is available at the DMR website at [http://www.waterboards.ca.gov/water\\_issues/programs/discharge\\_monitoring](http://www.waterboards.ca.gov/water_issues/programs/discharge_monitoring).

As of the effective date of this Order, if the Discharger does not operate a “major” facility as designated on page 1 of this Order, electronic DMR submittal is not required. However, at any time during the term of this Order, the State Water Board or Regional Water Board may notify and require the Discharger to submit DMRs.

## **VI. MODIFICATIONS TO ATTACHMENT G**

This MRP modifies Attachment G as indicated below:

### **A. Attachment G section V.C.1.c.2 is revised as follows:**

- 2) When determining compliance with an average monthly or maximum daily effluent limitation, and more than one sample result is available, the Discharger shall compute the arithmetic mean unless the data set contains one or more reported determinations of detected but not quantified (DNQ) or nondetect (ND). In those cases, the Discharger shall compute the median in place of the arithmetic mean in accordance with the following procedure:
  - i. The data set shall be ranked from low to high, reported ND determinations lowest, DNQ determinations next, followed by quantified values (if any). The order of the individual ND or DNQ determinations is unimportant.
  - ii. The median value of the data set shall be determined. If the data set has an odd number of data points, then the median is the middle value. If the data set has an even number of data points, then the median is the average of the two values around the middle unless one or both of the points are ND or DNQ, in which case the median value shall be the lower of the two data points where DNQ is lower than a value and ND is lower than DNQ.

If a sample result, or the arithmetic mean or median of multiple sample results, is below the reporting limit, and there is evidence that the priority pollutant is present in the effluent above an effluent limitation and the Discharger conducts a Pollutant Minimization Program, the Discharger shall not be deemed out of compliance.

**B. Attachment G sections V.C.1.f and V.C.1.g are revised as follows, and section V.C.1.h (Reporting data in electronic format) is deleted:**

f. Annual self-monitoring report requirements

By the date specified in the MRP, the Discharger shall submit an annual report to the Regional Water Board covering the previous calendar year. The report shall contain the following:

- 1) Annual compliance summary table of treatment plant performance, including documentation of any blending events (this summary table is not required if the Discharger has submitted the year's monitoring results to CIWQS in electronic reporting format by EDF/CDF upload or manual entry);
- 2) Comprehensive discussion of treatment plant performance and compliance with the permit (This discussion shall include any corrective actions taken or planned, such as changes to facility equipment or operation practices that may be needed to achieve compliance, and any other actions taken or planned that are intended to improve performance and reliability of the Discharger's wastewater collection, treatment, or disposal practices.);
- 3) Both tabular and graphical summaries of the monitoring data for the previous year if parameters are monitored at a frequency of monthly or greater (this item is not required if the Discharger has submitted the year's monitoring results to CIWQS in electronic reporting format by EDF/CDF upload or manual entry);
- 4) List of approved analyses, including the following:
  - (i) List of analyses for which the Discharger is certified;
  - (ii) List of analyses performed for the Discharger by a separate certified laboratory (copies of reports signed by the laboratory director of that laboratory shall not be submitted but be retained onsite); and
  - (iii) List of "waived" analyses, as approved;
- 5) Plan view drawing or map showing the Discharger's facility, flow routing, and sampling and observation station locations;
- 6) Results of annual facility inspection to verify that all elements of the SWPP Plan are accurate and up to date (only required if the Discharger does not route all stormwater to the headworks of its wastewater treatment plant); and
- 7) Results of facility report reviews (The Discharger shall regularly review, revise, and update, as necessary, the O&M Manual, the Contingency Plan, the Spill Prevention Plan, and Wastewater Facilities Status Report so that these documents remain useful and relevant to current practices. At a minimum, reviews shall be conducted annually. The Discharger shall include, in each Annual Report, a description or summary of review and evaluation procedures, recommended or planned actions, and an estimated time schedule for implementing these actions.



The Discharger shall complete changes to these documents to ensure they are up-to-date.).

g. Report submittal

The Discharger shall submit SMRs addressed as follows, unless the Discharger submits SMRs electronically to CIWQS:

California Regional Water Quality Control Board  
San Francisco Bay Region  
1515 Clay Street, Suite 1400  
Oakland, CA 94612  
Attn: NPDES Wastewater Division

h. Reporting data in electronic format – *Deleted*

**C. Attachment G sections V.E.2, V.E.2.a, and V.E.2.c are revised as follows, and sections V.E.2.b (24-hour Certification) and V.E.2.d (Communication Protocol) are deleted:**

2. Unauthorized Discharges from Municipal Wastewater Treatment Plants<sup>1</sup>

The following requirements apply to municipal wastewater treatment plants that experience an unauthorized discharge at their treatment facilities and supersede requirements imposed on the Discharger by the Executive Officer by letter of May 1, 2008:

a. Two (2)-Hour Notification

For any unauthorized discharges that enter a drainage channel or a surface water, the Discharger shall, as soon as possible, but not later than two (2) hours after becoming aware of the discharge, notify the California Office of Emergency Services (CalOES, currently 800-852-7550), the local health officers or directors of environmental health with jurisdiction over the affected water bodies, and the Regional Water Board. Timely notification by the Discharger to CalOES also satisfies notification to the Regional Water Board. Notification shall include the following:

- 1) Incident description and cause;
- 2) Location of threatened or involved waterway(s) or storm drains;
- 3) Date and time the unauthorized discharge started;
- 4) Estimated quantity and duration of the unauthorized discharge (to the extent known), and the estimated amount recovered;

---

<sup>1</sup> California Code of Regulations, Title 23, Section 2250(b), defines an unauthorized discharge to be a discharge, not regulated by waste discharge requirements, of treated, partially treated, or untreated wastewater resulting from the intentional or unintentional diversion of wastewater from a collection, treatment or disposal system.

- 5) Level of treatment prior to discharge (e.g., raw wastewater, primary treated, undisinfected secondary treated, and so on); and
  - 6) Identity of the person reporting the unauthorized discharge.
- b. 24-hour Certification – *Deleted*
- c. 5-day Written Report

Within five business days, the Discharger shall submit a written report that includes, in addition to the information required above, the following:

- 1) Methods used to delineate the geographical extent of the unauthorized discharge within receiving waters;
  - 2) Efforts implemented to minimize public exposure to the unauthorized discharge;
  - 3) Visual observations of the impacts (if any) noted in the receiving waters (e.g., fish kill, discoloration of water) and the extent of sampling if conducted;
  - 4) Corrective measures taken to minimize the impact of the unauthorized discharge;
  - 5) Measures to be taken to minimize the chances of a similar unauthorized discharge occurring in the future;
  - 6) Summary of Spill Prevention Plan or O&M Manual modifications to be made, if necessary, to minimize the chances of future unauthorized discharges; and
  - 7) Quantity and duration of the unauthorized discharge, and the amount recovered.
- d. Communication Protocol – *Deleted*

## ATTACHMENT F - FACT SHEET

### Contents

I.	Permit Information.....	F-2
II.	Facility Description.....	F-3
	A. Wastewater Collection and Treatment .....	F-3
	B. Discharge Point and Receiving Water.....	F-4
	C. Summary of Previous Requirements and Monitoring Data .....	F-4
	D. Compliance Summary .....	F-5
	E. Planned Changes .....	F-5
III.	Applicable Plans, Policies, and Regulations.....	F-6
IV.	Rationale For Effluent Limitations and Discharge Specifications .....	F-8
	A. Discharge Prohibitions .....	F-8
	B. Conventional and Non-Conventional Pollutant Effluent Limitations .....	F-10
	1. Scope and Authority .....	F-10
	2. Effluent Limitations .....	F-10
	C. Toxic Pollutant Effluent Limitations.....	F-11
	1. Scope and Authority .....	F-11
	2. Beneficial Uses and Water Quality Criteria and Objectives .....	F-11
	3. Need for Water Quality-Based Effluent Limitations (Reasonable Potential Analysis) ..	F-13
	4. Effluent Limitations .....	F-18
	D. Discharge Requirement Considerations .....	F-19
V.	Rationale for Receiving Water Limitations .....	F-21
VI.	Rationale for Provisions.....	F-21
	A. Standard Provisions .....	F-21
	B. Monitoring and Reporting .....	F-21
	C. Special Provisions .....	F-21
	1. Reopener Provisions .....	F-22
	2. Effluent Characterization Study and Report .....	F-22
	3. Receiving Water Characterization Study and Report.....	F-22
	4. Pollutant Minimization Program .....	F-22
VII.	Rationale for Monitoring and Reporting Program .....	F-22
VIII.	Public Participation .....	F-24

### Tables

Table F-1.	Facility Information.....	F-2
Table F-2.	Historic Effluent Limitations and Monitoring Data.....	F-5
Table F-3.	Beneficial Uses.....	F-6
Table F-4.	Secondary Treatment Requirements .....	F-10
Table F-5.	Priority Pollutant Reasonable Potential Analysis.....	F-14
Table F-6.	WQBEL Calculations.....	F-18
Table F-7.	Monitoring Requirements Summary.....	F-23

## ATTACHMENT F – FACT SHEET

This Fact Sheet includes the legal requirements and technical rationale that serve as the basis for the requirements of this Order. As described in section II.B of the Order, the Regional Water Board incorporates this Fact Sheet as findings supporting the issuance of the Order.

### I. PERMIT INFORMATION

The following table summarizes administrative information related to the facility:

**Table F-1. Facility Information**

<b>WDID</b>	2 019060002
<b>CIWQS Place ID</b>	269042
<b>CIWQS Party ID</b>	47792
<b>Discharger</b>	Union Sanitary District
<b>Facility Name</b>	Raymond A. Boege Alvarado Wastewater Treatment Plant – Old Alameda Creek Intermittent Wet Weather Discharge
<b>Facility Address</b>	5072 Benson Road Union City, CA 94587 Alameda County
<b>Facility Contact, Title, Phone</b>	Armando Lopez, Manager, Treatment and Disposal Services, (510) 477-7517
<b>Authorized Person to Sign and Submit Reports</b>	Same as facility contact
<b>Mailing Address</b>	5072 Benson Road Union City, CA 94587
<b>Billing Address</b>	Same as mailing address
<b>Facility Type</b>	Publicly Owned Treatment Works (POTW)
<b>Major or Minor Facility</b>	Minor
<b>Threat to Water Quality</b>	2
<b>Complexity</b>	B
<b>Pretreatment Program</b>	NPDES Permit No. CA0037869
<b>Mercury and PCBs Requirements</b>	NPDES Permit No. CA0038849
<b>Nutrient Requirements</b>	NPDES Permit No. CA0038873
<b>Flap Gate Exercise Permitted Flow</b>	140,000 gallons per discharge
<b>EBDA Pipeline Contract Capacity</b>	42.9 million gallons per day (MGD)
<b>Watershed</b>	Lower San Francisco Bay
<b>Receiving Water</b>	Old Alameda Creek
<b>Receiving Water Type</b>	Freshwater (during wet weather events, for the purposes of this Order)

- A. The Union Sanitary District (Discharger) owns and operates the Raymond A. Boege Alvarado Wastewater Treatment (plant) and its associated wastewater collection system (collectively, the Facility). The plant provides secondary treatment of wastewater collected from its service area and, during wet weather, discharges treated effluent to Old Alameda Creek, a water of the United States within the Lower San Francisco Bay watershed.

For purposes of this Order, references to the “discharger” or “permittee” in applicable federal and State laws, regulations, plans, and policies are held to be equivalent to references to the Discharger herein.

The Discharger is authorized to discharge subject to waste discharge requirements in this Order at the discharge location described in Table 2 of this Order. Regulations at 40 C.F.R. section 122.46 limit the duration of NPDES permits to a fixed term not to exceed five years. Accordingly, Table 3 of this Order limits the effective period for the discharge authorization. Pursuant to California Code of Regulations, title 23, section 2235.4, the terms and conditions of an expired permit are automatically continued pending reissuance of the permit if the Discharger complies with all federal NPDES regulation requirements for continuation of expired permits.

- B.** The Discharger's wet weather discharges are regulated pursuant to National Pollutant Discharge Elimination System (NPDES) Permit No. CA0038733. The Discharger was previously subject to Order No. R2-2010-0097 (previous order), which became effective on September 1, 2010, and was administratively extended by operation of law beyond its stated expiration date (August 31, 2015).

The Discharger is a member of the East Bay Dischargers Authority (EBDA). EBDA operates under a Joint Exercise of Powers Agreement among the City of Hayward, City of San Leandro, Union Sanitary District, Oro Loma Sanitary District, Castro Valley Sanitary District, and the Livermore-Amador Valley Water Management Agency. By contractual agreement, EBDA transports treated wastewater from its member agencies to its dechlorination station near the San Leandro Marina and then to its deep-water outfall for discharge to San Francisco Bay. The discharge through the deep-water outfall is regulated under NPDES Permit No. CA0037869.

The Discharger also discharges to Hayward Marsh, a constructed wastewater marsh system owned and operated by the East Bay Regional Park District. NPDES Permit No. CA0038636 regulates the Hayward Marsh discharge. That permit does not regulate wet weather discharges to Old Alameda Creek.

The Discharger is also regulated under NPDES Permit Nos. CA0038849 and CA0038873, which establish requirements on mercury and polychlorinated biphenyls (PCBs) and nutrients from wastewater discharges to San Francisco Bay. Those permits do not regulate wet weather discharges to Old Alameda Creek.

- C.** When applicable, State law requires dischargers to file a petition with the State Water Resources Control Board (State Water Board), Division of Water Rights, and receive approval for any change in the point of discharge, place of use, or purpose of use of treated wastewater that decreases the flow in any portion of a watercourse. The State Water Board retains separate jurisdictional authority to enforce such requirements under Water Code section 1211. This is not an NPDES permit requirement.
- D.** The Discharger filed a Report of Waste Discharge and submitted an application for reissuance of its Waste Discharge Requirements (WDRs) and NPDES permit on February 26, 2015.

## **II. FACILITY DESCRIPTION**

### **A. Wastewater Collection and Treatment**

- 1. Location and Service Area.** The plant is located at 5072 Benson Road in Union City. It provides secondary treatment of domestic and commercial wastewater from Fremont, Newark, and Union City. The estimated service area population is about 340,000.

Attachment B provides a map of the area around the Facility.

2. **Collection System.** The Discharger operates approximately 811 miles of separate sewer lines and three pump stations. There is one pump station for each of three basins in the service area: Alvarado Basin, Newark Basin, and Irvington Basin. Wastewater in each basin flows by gravity to the pump station.
3. **Treatment.** Wastewater treatment processes at the plant include screening, primary sedimentation, activated sludge, secondary clarification, and chlorination. Attachment C provides a plant flow schematic. The average dry weather design treatment capacity of the plant is 33 million gallons per day (MGD).

## **B. Discharge Point and Receiving Water**

Two pipelines transport plant effluent. One leads to the EBDA common outfall pipeline and Hayward Marsh. The other leads to the intermittent wet weather outfall (Discharge Point No. 001), which is the subject of this Order.

The wet weather outfall is a shallow water outfall that does not have a diffuser. The discharge location is about three miles upstream of Lower San Francisco Bay. There are two types of discharges from the wet weather outfall: discharges during peak wet weather conditions and discharges from exercising the discharge flap gate located in the wet weather outfall pipeline for maintenance purposes.

The agreement with EBDA and its other agencies allots 42.9 MGD of capacity in the EBDA outfall pipeline to the Discharger. Due to hydraulic limitations, the actual instantaneous maximum capacity available may be more or less than 42.9 MGD during wet weather. The average discharge rate to the EBDA pipeline over the previous order term was 24 MGD. If flow exceeds the maximum hydraulic capacity of the EBDA pipeline, the Discharger must discharge to the wet weather outfall to avoid flooding and damaging the plant.

The Discharger exercises the discharge flap gate to ensure that the line is flushed and the gate is operational when it is necessary to use the outfall during wet weather. The discharge flap gate is exercised briefly up to twice per year during the wet season (November 1 to April 30) during storms that produce a significant increase in Old Alameda Creek flow. These discharges have ranged from about 57,000 to 91,000 gallons.

Other than discharges during discharge flap gate exercises, no wet weather discharges to Old Alameda Creek have occurred since February 1998. On three days that month, discharge volumes ranged from 980,000 gallons to 1,340,000 gallons, and discharge durations ranged from two to three hours each time. Future discharges are expected to be infrequent (approximately once every 10 years) and are only expected during peak wet weather events when natural flows in Old Alameda Creek are high.

## **C. Summary of Previous Requirements and Monitoring Data**

The effluent limitations in the previous order and representative monitoring data from the previous order term are presented below:

**Table F-2. Historic Effluent Limitations and Monitoring Data**

Parameter	Units	Effluent Limitations			Monitoring Data (9/1/2010-4/30/2015)		
		Monthly Average	Weekly Average	Daily Maximum	No. of Samples / No. Below Detection Limit	Highest Daily Discharge	Average ± Standard Deviation <sup>[1]</sup>
Biochemical Oxygen Demand (BOD <sub>5</sub> )	mg/L	---	40	---	487 / 9 <sup>[2]</sup>	16 <sup>[2]</sup>	6.3±2.1 <sup>[2]</sup>
Total Suspended Solids (TSS)	mg/L	---	45	---	1,724 / 9	33	14±4.3
Oil and Grease	mg/L	---	---	20	4 / 4	<2.2	2.0±1.0
pH	standard units	6.5 - 8.5			511 / 0	7.0 - 7.4 <sup>[3]</sup>	7.2±1.0
Residual Chlorine, Total	mg/L	0.0 maximum			6 / 0	0.5	0.1±0.2
Fecal Coliform	MPN/100 ml	---	---	400	439 / 0	900 <sup>[4]</sup>	70±90
Copper, Total	µg/L	31	---	63	56 / 0	11	5.5±1.5
Lead, Total	µg/L	3.8	---	8.5	56 / 7	0.92	0.13±0.12
Cyanide, Total	µg/L	44	---	137	70 / 62	DNQ 4.7	1.5±0.9

Unit Abbreviations:

mg/L = milligrams per liter  
 µg/L = micrograms per liter  
 MPN/100ml = most probable number per 100 milliliters  
 DNQ = detected but not quantified

Footnotes:

- <sup>[1]</sup> Samples below the detection limit are assumed to be one half the detection limit.  
<sup>[2]</sup> Measured as CBOD<sub>5</sub>.  
<sup>[3]</sup> Lowest and highest values.  
<sup>[4]</sup> The Discharger did not violate the daily maximum effluent limitation of 400 MPN/100 mL in this instance because this maximum value was observed in dry weather discharge to the EBDA common outfall. The maximum value observed in discharge to Old Alameda Creek was 53 MPN/100 mL.

**D. Compliance Summary**

The Discharger violated its effluent limitation once during the previous order term on December 11, 2014, when it measured a total residual chlorine concentration of 0.5 mg/L during a discharge flap gate exercise. The instantaneous maximum effluent limitation was 0.0 mg/L.

The reason for the residual chlorine limitation exceedance was that the dechlorination pump responded too slowly to changes in discharge flow. The Discharger has since improved the responsiveness of its dechlorination system to prevent future violations. Enforcement for this violation is pending.

**E. Planned Changes**

No changes are planned for the term of this Order.

### III. APPLICABLE PLANS, POLICIES, AND REGULATIONS

#### A. Legal Authorities

This Order serves as WDRs pursuant to California Water Code article 4, chapter 4, division 7 (commencing with § 13260). This Order is also issued pursuant to Clean Water Act (CWA) section 402 and implementing regulations adopted by U.S. EPA and Water Code chapter 5.5, division 7 (commencing with § 13370). It shall serve as an NPDES permit for point source discharges from this facility to surface waters.

#### B. California Environmental Quality Act

Under Water Code section 13389, this action to adopt an NPDES permit is exempt from the provisions of the California Environmental Quality Act, Public Resources Code division 13, chapter 3 (commencing with § 21100).

#### C. State and Federal Regulations, Policies, and Plans

- 1. Water Quality Control Plan.** The Regional Water Board adopted the *Water Quality Control Plan for the San Francisco Bay Basin* (Basin Plan), which designates beneficial uses, establishes water quality objectives, and contains implementation programs and policies to achieve those objectives for all waters addressed through the plan. Requirements in this Order implement the Basin Plan.

The Basin Plan implements State Water Board Resolution No. 88-63, which establishes State policy that all waters, with certain exceptions, should be considered suitable or potentially suitable for municipal or domestic supply. Total dissolved solids levels in Old Alameda Creek commonly exceed 3,000 milligrams per liter (mg/L), even during the wet season from November 1 to April 30, because of the tidal influence of San Francisco Bay. Old Alameda Creek may exhibit freshwater conditions during peak wet weather when discharges are necessary, but these short-term circumstances are too short-lived to provide a good source of drinking water and support the municipal and domestic supply beneficial use. Therefore, Old Alameda Creek meets an exception to State Water Board Resolution No. 88-63. The table below lists beneficial uses applicable to Old Alameda Creek:

**Table F-3. Beneficial Uses**

Discharge Points	Receiving Waters	Beneficial Uses
001	Old Alameda Creek	Estuarine Habitat (EST) Wildlife Habitat (WILD) Water Contact Recreation (REC1) Non-Contact Water Recreation (REC2)

- 2. National Toxics Rule (NTR) and California Toxics Rule (CTR).** U.S. EPA adopted the NTR on December 22, 1992, and amended it on May 4, 1995 and November 9, 1999. About 40 criteria in the NTR apply in California. On May 18, 2000, U.S. EPA adopted the CTR. The CTR promulgated new toxics criteria for California and incorporated the previously adopted NTR criteria that applied in the State. U.S. EPA amended the CTR on February 13, 2001. These rules contain water quality criteria for priority pollutants.



- 3. State Implementation Policy.** On March 2, 2000, the State Water Board adopted the *Policy for Implementation of Toxics Standards for Inland Surface Waters, Enclosed Bays, and Estuaries of California* (State Implementation Policy or SIP). The SIP became effective on April 28, 2000, with respect to the priority pollutant criteria U.S. EPA promulgated for California through the NTR and the priority pollutant objectives the Regional Water Board established in the Basin Plan. The SIP became effective on May 18, 2000, with respect to the priority pollutant criteria U.S. EPA promulgated through the CTR. The State Water Board adopted amendments to the SIP on February 24, 2005, that became effective on July 13, 2005. The SIP establishes implementation provisions for priority pollutant criteria and objectives, and provisions for chronic toxicity control. Requirements of this Order implement the SIP.
- 4. Antidegradation Policy.** Federal regulations at 40 C.F.R. section 131.12 requires that state water quality standards include an antidegradation policy consistent with the federal policy. The State Water Board established California's antidegradation policy through State Water Board Resolution No. 68-16, *Statement of Policy with Respect to Maintaining High Quality of Waters in California*, which is deemed to incorporate the federal antidegradation policy where the federal policy applies under federal law. Resolution No. 68-16 requires that existing water quality be maintained unless degradation is justified based on specific findings. The Basin Plan implements, and incorporates by reference, both the State and federal antidegradation policies. Permitted discharges must be consistent with the antidegradation provisions of 40 C.F.R. section 131.12 and State Water Board Resolution No. 68-16.
- 5. Anti-Backsliding Requirements.** CWA sections 402(o) and 303(d)(4) and 40 C.F.R. section 122.44(l) restrict backsliding in NPDES permits. These anti-backsliding provisions require that effluent limitations in a reissued permit be as stringent as those in the previous order, with some exceptions in which limitations may be relaxed.
- 6. Endangered Species Act Requirements.** This Order does not authorize any act that results in the taking of a threatened or endangered species or any act that is now prohibited, or becomes prohibited in the future, under either the California Endangered Species Act (Fish and Game Code, §§ 2050 to 2097) or the Federal Endangered Species Act (16 U.S.C.A. §§ 1531 to 1544). This Order requires compliance with effluent limits, receiving water limits, and other requirements to protect the beneficial uses of waters of the State. The Discharger is responsible for meeting all applicable Endangered Species Act requirements.

#### **D. Impaired Waters on CWA 303(d) List**

In October 2011, U.S. EPA approved a revised list of impaired waters pursuant to CWA section 303(d), which requires identification of specific water bodies where it is expected that water quality standards will not be met after implementation of technology-based effluent limitations on point sources. Where it has not done so already, the Regional Water Board plans to adopt total maximum daily loads (TMDLs) for pollutants on the 303(d) list. TMDLs establish wasteload allocations for point sources and load allocations for non-point sources and are established to achieve the water quality standards for the impaired waters.

Old Alameda Creek is listed as impaired for trash. The discharge is not a source of trash because it is screened and treated to secondary treatment standards.

## IV. RATIONALE FOR EFFLUENT LIMITATIONS AND DISCHARGE SPECIFICATIONS

The CWA requires point source dischargers to control the amount of conventional, non-conventional, and toxic pollutants discharged into waters of the United States. The control of pollutants discharged is established through effluent limitations and other requirements in NPDES permits. There are two principal bases for effluent limitations: 40 C.F.R. section 122.44(a) requires that permits include applicable technology-based limitations and standards, and 40 C.F.R. section 122.44(d) requires that permits include water quality-based effluent limitations to attain and maintain applicable numeric and narrative water quality criteria to protect the beneficial uses of receiving waters.

### A. Discharge Prohibitions

#### 1. Prohibitions in this Order

- a. **Discharge Prohibition III.A (Discharge different than as described in this Order is prohibited):** This prohibition is based on 40 C.F.R. section 122.21(a) and Water Code section 13260, which require filing an application and Report of Waste Discharge before a discharge can occur. Discharges not described in the application and Report of Waste Discharge, and subsequently in this Order, are prohibited.
- b. **Discharge Prohibition III.B (Discharge is prohibited, except during peak wet weather):** This prohibition ensures that discharges to Old Alameda Creek occur only during peak wet weather when the maximum hydraulic capacity available in the EBDA pipeline is fully utilized and when exercising the discharge flap gate. Peak wet weather discharges are expected to exceed the available capacity in the EBDA pipeline approximately once every 10 years. Flows above 140,000 gallons are prohibited during flap gate exercises so discharges only occur to the extent necessary to complete the tests. This volume is about 50 percent greater than the largest volume the Discharger has discharged in the past when exercising the flap gate. Prohibiting discharges except under these conditions is consistent with Basin Plan Discharge Prohibition 1 (Basin Plan Table 4-1).
- c. **Discharge Prohibition III.C (Bypass is prohibited):** This prohibition is based on 40 C.F.R. section 122.41(m) (see Attachment D section I.G).
- d. **Discharge Prohibition III.D (Discharge during discharge flap gate exercises more than twice per year is prohibited):** This prohibition restricts potential water quality impacts on Old Alameda Creek resulting from discharge flap gate exercises by limiting such discharges to twice per year and requiring that they occur during significant wet weather events when flow in Old Alameda Creek is high. This prohibition ensures that discharges only occur when Old Alameda Creek flows provide significant mixing and dilution, and during conditions that reflect the assumptions underlying the reasonable potential analysis, effluent limitations, and other requirements of this Order.

#### 2. Shallow Water Discharge Prohibition

The Discharger has not demonstrated that the discharge receives an initial dilution of at least 10:1 as it enters the shallow waters of Old Alameda Creek. Basin Plan Table 4-1, Discharge

Prohibition 1, prohibits wastewater discharges that have particular characteristics of concern to beneficial uses if they do not receive a minimum initial dilution of at least 10:1. The purpose of Discharge Prohibition 1 is to protect against the following:

- continuous effects of waste discharge;
- effects of abnormal discharges caused by temporary plant upsets or malfunctions;
- public contact with undiluted waste; and
- visual impacts.

Treated sewage and other discharges subject to treatment process upsets are assumed to have particular characteristics of concern unless the discharge of inadequately treated waste will be reliably prevented. In this case, discharge of inadequately-treated waste is reliably prevented, and the discharge does not have particular characteristics of concern to the beneficial uses of Old Alameda Creek for the following reasons:

- The discharge of inadequately treated waste is reliably prevented because, under most possible upset conditions, Facility effluent would flow to the EBDA common outfall and Hayward Marsh. Discharge to the wet weather outfall requires an intentional flow diversion. In the few instances of discharges from the wet weather outfall, wastewater receives reliable treatment because the plant has a good compliance record. The few instances of past problems have been resolved (see Fact Sheet section II.D).
- Discharges are infrequent. Wet weather discharges occur approximately once every 10 years, and discharge flap gate exercises occur no more than twice per year. Discharges do not have continuous effects on Old Alameda Creek beneficial uses because they occur only during wet weather, when discharges are flushed by at least 250 MGD of increased creek flows (*Draft Hydrology and Hydraulics Report for the East-West Connector*, WRECO, March 2009; *Mixing Zone Analysis Update*, RMC, March 2015) and stormwater from the Alvarado Flood Control Pump Station outfall located about 100 feet downstream.

Therefore, Discharge Prohibition 1 does not apply to this discharge. However, if it did, Basin Plan section 4.2 provides for exceptions under certain circumstances:

- An inordinate burden would be placed on the Discharger relative to the beneficial uses protected, and an equivalent level of environmental protection can be achieved by alternate means;
- A discharge is approved as part of a reclamation project;
- Net environmental benefits will be derived as a result of the discharge; or
- A discharge is approved as part of a groundwater cleanup project.

The Basin Plan further states:

Significant factors to be considered by the Regional Water Board in reviewing requests for exceptions will be the reliability of the discharger's system in preventing inadequately treated wastewater from being discharged to the receiving water and the environmental consequence of such discharges.

The discharge would qualify for an exception to Discharge Prohibition 1 based on the following:

- a. Moving the discharge to a deep-water outfall (e.g., expanding the capacity of the EBDA common pipeline) would constitute an inordinate burden on the Discharger because it would be unreasonably costly for a discharge that only occurs approximately once every 10 years.
- b. The Discharger provides an equivalent level of environmental protection by preventing discharges that occur more frequently than approximately once every 10 years. Moreover, the Discharger reliably prevents inadequately treated wastewater from being discharged because, under most possible upset conditions, effluent would flow to the EBDA common outfall and Hayward Marsh, not Old Alameda Creek.

**B. Conventional and Non-Conventional Pollutant Effluent Limitations**

**1. Scope and Authority**

CWA section 301(b) and 40 C.F.R. section 122.44 require that permits include conditions meeting technology-based requirements, at a minimum, and any more stringent effluent limitations necessary to meet water quality standards. The discharges authorized by this Order must meet minimum federal technology-based requirements based on the Secondary Treatment Standards at 40 C.F.R. section 133 as summarized below. In addition, the 30-day average percent removal for biochemical oxygen demand (BOD<sub>5</sub>) (or carbonaceous biochemical oxygen demand [CBOD<sub>5</sub>]) and total suspended solids (TSS), by concentration, is not to be less than 85 percent. The Basin Plan contains additional requirements for certain pollutants.

**Table F-4. Secondary Treatment Requirements**

Parameter	Units	Monthly Average	Weekly Average	Instantaneous Minimum	Instantaneous Maximum
BOD <sub>5</sub> <sup>[1]</sup>	mg/L	30	45	---	---
CBOD <sub>5</sub> <sup>[1]</sup>	mg/L	25	40	---	---
TSS	mg/L	30	45	---	---
pH	standard units	---	---	6.5	8.5

Unit Abbreviation:

mg/L = milligrams per liter

Footnote:

<sup>[1]</sup> CBOD<sub>5</sub> effluent limitations may be substituted for BOD<sub>5</sub> limitations.

**2. Effluent Limitations**

- a. **CBOD<sub>5</sub> and TSS.** The CBOD<sub>5</sub> and TSS effluent limitations are based on the Secondary Treatment Standards and Basin Plan Table 4-2. Due to the infrequent nature of the discharge, this Order contains only the weekly average limitations, not the monthly average limitations. NPDES Permit No. CA0037869 (for the EBDA common outfall) ensures that the Facility satisfies monthly average effluent limitations in accordance with the Secondary Treatment Standards.
- b. **Oil and Grease.** The oil and grease effluent limitation is based on Basin Plan Table 4-2.

- c. **pH.** The pH effluent limitation is based on the Secondary Treatment Standards and Basin Plan Table 4-2.
- d. **Total Residual Chlorine.** The total residual chlorine effluent limitation is based on Basin Plan Table 4-2.
- e. **Fecal Coliform.** The fecal coliform effluent limitation is based on Basin Plan Table 4-2A, footnotes b and c. Footnote b says the Regional Water Board will establish total coliform limitations in lieu of enterococcus limitations for intermittent discharges. Footnote c allows the Regional Water Board to substitute fecal coliform limits for total coliform limits if such substitution will not result in unacceptable adverse impacts to beneficial uses.

The daily maximum fecal coliform limit of 400 MPN/100ml is protective of the water contact recreation beneficial use because it is based on the fecal coliform water quality objective for water contact recreation shown in Basin Plan Table 3-1. In fact, because the limit is expressed as a daily maximum, it is more protective than the water contact recreation water quality objective, which is expressed as a 90<sup>th</sup> percentile. Expressing the limit as a daily maximum is more practical than using a 90<sup>th</sup> percentile due to the short duration of the discharge.

## C. Toxic Pollutant Effluent Limitations

### 1. Scope and Authority

For toxic pollutants, this Order contains water quality based effluent limitations (WQBELs) that implement water quality objectives that protect beneficial uses. CWA section 301(b) and 40 C.F.R. section 122.44(d) require that permits include limitations more stringent than federal technology-based requirements where necessary to achieve applicable water quality standards. According to 40 C.F.R. section 122.44(d)(1)(i), permits must include effluent limitations for all pollutants that are or may be discharged at levels that have a reasonable potential to cause or contribute to an exceedance of a water quality standard, including numeric and narrative objectives within a standard. Where reasonable potential has been established for a pollutant, but there is no numeric criterion or objective, WQBELs must be established using (1) U.S. EPA criteria guidance under CWA section 304(a), supplemented where necessary by other relevant information; (2) an indicator parameter for the pollutant of concern; or (3) a calculated numeric water quality criterion, such as a proposed state criterion or policy interpreting a narrative criterion, supplemented with relevant information (40 C.F.R. § 122.44[d][1][vi]). The process for determining reasonable potential and calculating WQBELs is intended to achieve applicable water quality objectives and criteria, and protect designated uses of receiving waters as specified in the Basin Plan. This Order imposes numeric effluent limitations for toxic pollutants with reasonable potential to cause or contribute to exceedances of water quality standards.

### 2. Beneficial Uses and Water Quality Criteria and Objectives

Discharge Point No. 001 discharges to Old Alameda Creek. Fact Sheet section III.C.1, above, identifies the beneficial uses of the Old Alameda Creek. Water quality criteria and objectives to protect these beneficial uses are described below:

- a. Basin Plan Objectives.** The Basin Plan specifies numeric water quality objectives for 10 priority pollutants and several narrative water quality objectives. The narrative toxicity objective states, “All waters shall be maintained free of toxic substances in concentrations that are lethal to or that produce other detrimental responses in aquatic organisms.”
- b. CTR Criteria.** The CTR specifies numeric aquatic life and human health criteria for numerous priority pollutants. These criteria apply to inland surface waters and enclosed bays and estuaries. Some human health criteria are for consumption of “water and organisms” and others are for consumption of “organisms only.” The criteria applicable to “organisms only” apply to Old Alameda Creek because it is not a potential source of drinking water.
- c. NTR Criteria.** The NTR establishes numeric aquatic life and human health criteria for a number of toxic pollutants for San Francisco Bay waters upstream to and including Suisun Bay and the Sacramento-San Joaquin Delta. The NTR criteria apply to Old Alameda Creek.
- d. Receiving Water Salinity.** Basin Plan section 4.6.2 (like the CTR and NTR) states that the salinity characteristics (i.e., freshwater vs. saltwater) of the receiving water are to be considered in determining applicable water quality objectives. Freshwater criteria apply to discharges to waters with salinities equal to or less than 1 part per thousand (ppt) at least 95 percent of the time. Saltwater criteria apply to discharges to waters with salinities equal to or greater than 10 ppt at least 95 percent of the time in a normal water year. For discharges to waters with salinities between these two categories, or tidally-influenced freshwaters that support estuarine beneficial uses, the water quality objectives are the lower of the salt or freshwater objectives (the latter calculated based on ambient hardness) for each substance.

The receiving water receives upstream freshwater flows but is tidally influenced, being located approximately three miles upstream from Lower San Francisco Bay. However, under peak wet weather conditions the receiving water is freshwater because of the large amount of stormwater flow from upstream. Because the receiving water would be freshwater during wet weather discharges, this Order’s effluent limitations are based on the freshwater water quality objectives and criteria in the Basin Plan, NTR, and CTR.
- e. Receiving Water Hardness.** Ambient hardness data were used to calculate freshwater water quality objectives that are hardness dependent. The Discharger collected receiving water hardness data between March 2009 and December 2014. Within this data set, eight data points reflect freshwater conditions (salinity less than or equal to 1 ppt). The adjusted geometric mean of these eight data points is 133 mg/L. This value was used to calculate the objectives.
- f. Site-Specific Metals Translators.** Effluent limitations for metals must be expressed as total recoverable metal (40 C.F.R. § 122.45[c]). Since the water quality objectives for metals are typically expressed as dissolved metal, translators must be used to convert metals concentrations from dissolved to total recoverable and vice versa. In general, dissolved metals are more available and more toxic to aquatic life than other forms. This Order relies on CTR default translators.

### 3. Need for Water Quality-Based Effluent Limitations (Reasonable Potential Analysis)

Assessing whether a pollutant has reasonable potential to exceed a water quality objective is the fundamental step in determining whether a WQBEL is required.

- a. Available Information.** The reasonable potential analysis for this Order is based on effluent monitoring data the Discharger collected between September 2010 and October 2014 and ambient background data collected in November 2012 and February 2014.

In some cases, reasonable potential cannot be determined because effluent or ambient background data are limited or water quality objective criteria have not been developed. Provision VI.C.2 of the Order requires the Discharger to continue monitoring for such constituents in its effluent using analytical methods that provide the best feasible detection limitations. When additional data become available, further analysis will be conducted to determine whether numeric effluent limitations are necessary.

This Order does not contain WQBELs for constituents that do not demonstrate reasonable potential; however, Provision VI.C.2 of the Order still requires monitoring for such pollutants. If concentrations are found to have increased significantly, Provision VI.C.2 of the Order requires the Discharger to investigate the sources of the increases and implement remedial measures if the increases pose a threat to receiving water quality.

- b. Priority Pollutants.** For the priority pollutants, the reasonable potential analysis for this Order is based on the methodology set forth in SIP section 1.3. The analysis begins with identifying the maximum effluent concentration (MEC) observed for each pollutant based on available effluent concentration data and the ambient background concentration (B). SIP section 1.4.3 states that ambient background concentrations are either the maximum ambient concentration observed or, for water quality objectives intended to protect human health, the arithmetic mean of observed concentrations. There are three triggers in determining reasonable potential:

- i. Trigger 1** is activated if the maximum effluent concentration is greater than or equal to the lowest applicable water quality objective ( $MEC \geq$  water quality objective).
- ii. Trigger 2** is activated if the ambient background concentration observed in the receiving water is greater than the lowest applicable water quality objective ( $B >$  water quality objective) *and* the pollutant is detected in any effluent sample.
- iii. Trigger 3** is activated if a review of other information indicates that a WQBEL is needed to protect beneficial uses.

The maximum effluent concentrations (MECs), most stringent applicable water quality criteria and objectives, and background concentrations used in the analysis are presented below, along with the reasonable potential analysis results (yes or no) for each pollutant. Lead exhibits reasonable potential by Trigger 2 based on a sample collected in February 2014.

**Table F-5. Priority Pollutant Reasonable Potential Analysis**

CTR No.	Pollutants	Governing Criterion or Objective (µg/L)	MEC or Minimum DL (µg/L) <sup>[1][2]</sup>	B or Minimum DL (µg/L) <sup>[1][2]</sup>	RPA Results <sup>[3]</sup>
1	Antimony	4,300	0.42	1.4	No
2	Arsenic	150	1.4	2.1	No
3	Beryllium	No Criteria	<0.03	0.047	U
4	Cadmium	1.03	0.4	0.097	No
5a	Chromium (III)	172	---	---	U
5b	Chromium (VI)	11	5.1	6.6	No
6	Copper	12	11	9.9	No
<b>7</b>	<b>Lead</b>	<b>4.6</b>	<b>0.92</b>	<b>6.2</b>	<b>Yes</b>
8	Mercury(303d listed)	0.025	0.011	0.014	No
9	Nickel	43	5.7	8.3	No
10	Selenium (303d listed)	5.0	0.54	1.3	No
11	Silver	2.8	0.086	<0.041	No
12	Thallium	6.3	0.25	<0.2	No
13	Zinc	99	26	32	No
14	Cyanide	5.2	4.7	<0.003	No
16	2,3,7,8-TCDD	$1.4 \times 10^{-8}$	$< 1.6 \times 10^{-7}$	$< 1.6 \times 10^{-7}$	U
17	Acrolein	780	<0.94	<2.9	No
18	Acrylonitrile	0.66	<0.31	<0.42	No
19	Benzene	71	<0.1	<0.1	No
20	Bromoform	360	0.3	<0.18	No
21	Carbon Tetrachloride	4.4	<0.11	<0.14	No
22	Chlorobenzene	21,000	<0.12	<0.12	No
23	Chlorodibromomethane	34	0.29	<0.13	No
24	Chloroethane	No Criteria	<0.11	<0.18	U
25	2-Chloroethylvinyl ether	No Criteria	<0.17	<0.25	U
26	Chloroform	No Criteria	1.5	<0.15	U
27	Dichlorobromomethane	46	0.33	<0.2	No
28	1,1-Dichloroethane	No Criteria	<0.097	<0.13	U
29	1,2-Dichloroethane	99	<0.1	<0.14	No
30	1,1-Dichloroethylene	3.2	<0.1	<0.19	No
31	1,2-Dichloropropane	39	<0.11	<0.13	No
32	1,3-Dichloropropylene	1,700	<0.18	<0.13	No
33	Ethylbenzene	29,000	<0.08	<0.13	No
34	Methyl Bromide	4,000	<0.23	<0.23	No
35	Methyl Chloride	No Criteria	<0.21	<0.32	U
36	Methylene Chloride	1,600	2.1	<0.24	No
37	1,1,2,2-Tetrachloroethane	11	<0.12	<0.12	No
38	Tetrachloroethylene	8.9	<0.09	<0.18	No
39	Toluene	200,000	0.91	<0.11	No
40	1,2-Trans-Dichloroethylene	140,000	<0.11	<0.19	No
41	1,1,1-Trichloroethane	No Criteria	<0.14	<0.16	U
42	1,1,2-Trichloroethane	42	<0.098	<0.2	No
43	Trichloroethylene	81	<0.1	<0.16	No



CTR No.	Pollutants	Governing Criterion or Objective (µg/L)	MEC or Minimum DL (µg/L) <sup>[1][2]</sup>	B or Minimum DL (µg/L) <sup>[1][2]</sup>	RPA Results <sup>[3]</sup>
44	Vinyl Chloride	525	<0.09	<0.09	No
45	2-Chlorophenol	400	<0.55	<0.56	No
46	2,4-Dichlorophenol	790	<0.6	<0.61	No
47	2,4-Dimethylphenol	2,300	<0.36	<0.36	No
48	2-Methyl- 4,6-Dinitrophenol	765	<0.96	<0.98	No
49	2,4-Dinitrophenol	14,000	<0.96	<0.98	No
50	2-Nitrophenol	No Criteria	<0.49	<0.5	U
51	4-Nitrophenol	No Criteria	<1.8	<1.9	U
52	3-Methyl 4-Chlorophenol	No Criteria	<0.55	<0.56	U
53	Pentachlorophenol	6.7	<1.7	<1.8	No
54	Phenol	4,600,000	<0.93	<0.95	No
55	2,4,6-Trichlorophenol	6.5	<0.58	<0.59	No
56	Acenaphthene	2,700	<0.03	<0.052	No
57	Acenaphthylene	No Criteria	<0.03	<0.039	U
58	Anthracene	110,000	<0.012	<0.064	No
59	Benzidine	0.00054	<4.8	<4.9	U
60	Benzo(a)Anthracene	0.049	<0.012	<0.02	No
61	Benzo(a)Pyrene	0.049	<0.012	<0.044	No
62	Benzo(b)Fluoranthene	0.049	<0.029	<0.031	No
63	Benzo(ghi)Perylene	No Criteria	<0.023	<0.023	U
64	Benzo(k)Fluoranthene	0.049	<0.015	<0.015	No
65	Bis(2-Chloroethoxy)Methane	No Criteria	<0.54	<0.55	U
66	Bis(2-Chloroethyl)Ether	1.4	<0.71	<0.73	No
67	Bis(2-Chloroisopropyl)Ether	170,000	<0.53	<0.54	No
68	Bis(2-Ethylhexyl)Phthalate	5.9	5.2	3	No
69	4-Bromophenyl Phenyl Ether	No Criteria	<0.6	<0.62	U
70	Butylbenzyl Phthalate	5,200	4	<0.65	No
71	2-Chloronaphthalene	4,300	<0.47	<0.48	No
72	4-Chlorophenyl Phenyl Ether	No Criteria	<0.58	<0.59	U
73	Chrysene	0.049	<0.017	<0.017	No
74	Dibenzo(a,h)Anthracene	0.049	<0.016	<0.016	No
75	1,2-Dichlorobenzene	17,000	<0.13	<0.13	No
76	1,3-Dichlorobenzene	2,600	<0.17	<0.17	No
77	1,4-Dichlorobenzene	2,600	<0.14	<0.15	No
78	3,3 Dichlorobenzidine	0.077	<0.57	<0.58	U
79	Diethyl Phthalate	120,000	1.4	1.4	No
80	Dimethyl Phthalate	2,900,000	<0.18	<0.19	No
81	Di-n-Butyl Phthalate	12,000	5.7	<0.86	No
82	2,4-Dinitrotoluene	9.1	<0.49	<0.5	No
83	2,6-Dinitrotoluene	No Criteria	<0.46	<0.47	U
84	Di-n-Octyl Phthalate	No Criteria	<0.96	<0.98	U
85	1,2-Diphenylhydrazine	0.54	<0.54	<0.55	U
86	Fluoranthene	370	<0.027	<0.027	No
87	Fluorene	14,000	<0.028	<0.049	No

CTR No.	Pollutants	Governing Criterion or Objective (µg/L)	MEC or Minimum DL (µg/L) <sup>[1][2]</sup>	B or Minimum DL (µg/L) <sup>[1][2]</sup>	RPA Results <sup>[3]</sup>
88	Hexachlorobenzene	0.00077	<0.49	<0.5	U
89	Hexachlorobutadiene	50	<0.55	<0.56	No
90	Hexachlorocyclopentadiene	17,000	<3.1	<3.1	No
91	Hexachloroethane	8.9	<0.48	<0.49	No
92	Indeno(1,2,3-cd)Pyrene	0.049	<0.016	<0.016	No
93	Isophorone	600	<0.56	<0.57	No
94	Naphthalene	No Criteria	<0.033	<0.071	U
95	Nitrobenzene	1,900	<0.68	<0.7	No
96	N-Nitrosodimethylamine	8.1	<0.72	<0.74	No
97	N-Nitrosodi-n-Propylamine	1.4	<0.8	<0.81	No
98	N-Nitrosodiphenylamine	16	<0.58	<0.59	No
99	Phenanthrene	No Criteria	<0.025	<0.042	U
100	Pyrene	11,000	<0.018	<0.029	No
101	1,2,4-Trichlorobenzene	No Criteria	<0.49	<0.5	U
102	Aldrin	0.00014	<0.0021	<0.0029	U
103	Alpha-BHC	0.013	<0.0029	<0.0029	No
104	Beta-BHC	0.046	<0.0019	<0.0029	No
105	Gamma-BHC	0.063	<0.0019	0.0092	No
106	Delta-BHC	No Criteria	<0.0029	<0.0029	U
107	Chlordane (303(d) listed)	0.00059	<0.013	<0.014	U
108	4,4'-DDT (303(d) listed)	0.00059	<0.0038	<0.0039	U
109	4,4'-DDE (linked to DDT)	0.00059	<0.0029	<0.0029	U
110	4,4'-DDD	0.00084	<0.0019	<0.0019	U
111	Dieldrin (303d listed)	0.00014	<0.0025	<0.0039	U
112	Alpha-Endosulfan	0.0087	<0.0019	<0.0039	No
113	beta-Endosulfan	0.0087	<0.0019	<0.0039	No
114	Endosulfan Sulfate	240	<0.0019	<0.0019	No
115	Endrin	0.0023	<0.0019	<0.0029	U
116	Endrin Aldehyde	0.81	<0.0029	<0.0039	No
117	Heptachlor	0.00021	<0.0029	<0.0029	U
118	Heptachlor Epoxide	0.00011	<0.0019	<0.0029	U
119-125	PCBs sum (303(d) listed)	0.00017	<0.019	<0.0194	U
126	Toxaphene	0.0002	<0.068	<0.069	U

**Abbreviations:**

MEC = maximum effluent concentration  
 B = background concentration  
 WQC = water quality criterion or objective  
 DL = minimum detection level

**Footnotes:**

- <sup>[1]</sup> The maximum effluent concentration and ambient background concentration are the actual detected concentrations unless preceded by a “<” sign, in which case the value shown is the DL.
- <sup>[2]</sup> The maximum effluent concentration or ambient background concentration is “Unavailable” when there are no monitoring data for the constituent.
- <sup>[3]</sup> RPA Results = Yes, if MEC ≥ WQC, B > WQC and MEC is detected, or Trigger 3  
 = No, if MEC and B are < WQC or all effluent data are undetected

= Unknown (U), if no criteria have been promulgated or data are insufficient.

**c. Ammonia**

- i. Methodology.** Ammonia is a toxic pollutant but not a priority pollutant; therefore, the procedure outlined in the *Technical Support Document for Water Quality-based Toxics Control* (Technical Support Document) (EPA/505/2-90-001, March 1991) was used to determine if ammonia in the discharge has a reasonable potential to cause water quality objectives to be exceeded in the receiving water. The Technical Support Document allows the use of measured receiving water concentrations or receiving water concentrations projected from effluent data to perform the reasonable potential analysis. In either case, the receiving water concentrations are compared to the Basin Plan objectives.

Data are available for total ammonia, but not un-ionized ammonia, because (1) sampling and laboratory methods are unavailable to analyze for un-ionized ammonia, and (2) the fraction of total ammonia that exists in the toxic un-ionized form depends on pH, salinity, and temperature. Total ammonia concentrations (as nitrogen) can be converted into un-ionized ammonia concentrations when concurrent pH and temperature data are available as follows (U.S. EPA, 1989, *Ambient Water Quality Criteria for Ammonia (Saltwater)—1989*, EPA Publication 440/5-88-004):

$$\text{For salinity} < 1 \text{ ppt: fraction of NH}_3 = \frac{1}{1 + 10^{(pK - pH)}}$$

Where:

$$pK = 0.09018 + 2729.92/T$$

T = Temperature (Kelvin)

Effluent un-ionized ammonia concentrations cannot be calculated because total ammonia, temperature, and pH data were not collected concurrently. Accordingly, the ammonia reasonable potential analysis is based only on receiving water data.

- ii. Ammonia Objective.** Basin Plan section 3.3.20 contains un-ionized ammonia water quality objectives of 0.025 mg/L as an annual median and 0.4 mg/L as a maximum for South San Francisco Bay, the water body to which Old Alameda Creek flows. The annual median objective is irrelevant for this Order because the discharge is so infrequent that it cannot affect the annual median concentration in Old Alameda Creek.
- iii. Analysis.** Two receiving water sampling events for total ammonia, pH, salinity, and temperature took place in November 2012 and February 2014. The highest un-ionized ammonia concentration of 0.003 mg/L (as nitrogen) was less than the maximum water quality objective of 0.4 mg/L. Therefore, there appears to be no reasonable potential for ammonia. The MRP requires additional ammonia monitoring.
- d. Whole Effluent Toxicity.** Because wet weather discharges are rare (occurring approximately once every 10 years), the Discharger does not conduct acute or chronic toxicity bioassays, and toxicity effluent limitations are unwarranted due to the short-term and infrequent nature of the discharge. Moreover, in accordance with NPDES Permit

No. CA0037869, whole effluent toxicity is indirectly limited as part of the Discharger's discharge to the EBDA common outfall.

#### 4. Effluent Limitations

WQBELs were developed for lead because it was determined to have reasonable potential to cause or contribute to exceedances of water quality objectives. The WQBEL calculations are based on SIP section 1.4 as shown in the following table:

**Table F-6. WQBEL Calculations**

<b>PRIORITY POLLUTANTS</b>	<b>Lead</b>
<b>Units</b>	<b>ug/L</b>
Basis and Criteria type	CTR Freshwater Criteria
Criteria -Acute	117
Criteria -Chronic	4.6
SSO Criteria -Acute	-----
SSO Criteria -Chronic	-----
Water Effects ratio (WER)	1
Lowest WQO	4.6
Site Specific Translator - MDEL	-----
Site Specific Translator - AMEL	-----
Dilution Factor (D) (if applicable)	0
No. of samples per month	4
Aquatic life criteria analysis required? (Y/N)	Y
HH criteria analysis required? (Y/N)	N
Applicable Acute WQO	117
Applicable Chronic WQO	4.6
HH criteria	-----
Background (Maximum Conc for Aquatic Life calc)	6.2
Background (Average Conc for Human Health calc)	-----
Is the pollutant on the 303d list and/or bioaccumulative (Y/N)?	N
ECA acute	117
ECA chronic	4.6
ECA HH	-----
No. of data points <10 or at least 80% of data reported non detect? (Y/N)	N
Avg of effluent data points	0.13
Std Dev of effluent data points	0.12
CV calculated	0.91
CV (Selected) - Final	0.91
ECA acute mult99	0.22
ECA chronic mult99	0.40
LTA acute	26
LTA chronic	1.8
minimum of LTAs	1.8

<b>PRIORITY POLLUTANTS</b>	<b>Lead</b>
<b>Units</b>	<b>ug/L</b>
AMEL mult95	1.9
MDEL mult99	4.5
AMEL (aq life)	3.4
MDEL(aq life)	8.3
MDEL/AMEL Multiplier	2.4
AMEL (human hlth)	-----
MDEL (human hlth)	-----
minimum of AMEL for Aq. life vs HH	3.4
minimum of MDEL for Aq. Life vs HH	8.3
Previous order limit (average monthly)	3.8
Previous order limit (maximum daily)	8.5
Final limit - AMEL	<b>3.4</b>
Final limit - MDEL	<b>8.3</b>

**D. Discharge Requirement Considerations**

- 1. Anti-backsliding.** This Order complies with the anti-backsliding provisions of CWA sections 402(o) and 303(d)(4), and 40 C.F.R. section 122.44(1), which generally require effluent limitations and requirements in a reissued permit to be as stringent as those in the previous order. The requirements of this Order are at least as stringent as those in the previous order, with the exceptions noted below.

This Order corrects a technical error in the previous order, which had imposed a weekly average BOD<sub>5</sub> effluent limitation of 40 mg/L instead of a CBOD<sub>5</sub> limitation of 40 mg/L. The previous BOD<sub>5</sub> limitation was inconsistent with the minimum federal Secondary Treatment Standards and Basin Plan Table 4-2. It was also clearly a mistake because the previous order Fact Sheet indicated that the BOD<sub>5</sub> limitation was retained from its preceding order (Order No. R2-2004-0002), which had contained a weekly average CBOD<sub>5</sub> limit of 40 mg/L. Consistent with CWA section 402(o)(2)(B)(ii), this Order corrects the typographical error and imposes a weekly average CBOD<sub>5</sub> effluent limitation of 40 mg/L.

This Order does not retain the average monthly percent removal requirement for CBOD<sub>5</sub> and TSS from the previous order because of the infrequent nature of the discharge. NPDES Permit No. CA0037869 (for the EBDA common outfall) requires the average monthly percent removal and ensures that the Facility will continue to meet the Secondary Treatment Standards.

This Order also does not retain cyanide and copper effluent limits from the previous order because there is no reasonable potential for cyanide or copper to exceed water quality objectives. This is consistent with State Water Board Order No. WQ 2001-16.

- 2. Antidegradation.** This Order complies with the antidegradation provisions of 40 C.F.R. section 131.12 and State Water Board Resolution No. 68-16. It continues the status quo with

respect to the level of discharge authorized in the previous order, which is the baseline by which to measure whether degradation will occur. This Order does not allow for a reduced level of treatment.

The weekly average CBOD<sub>5</sub> effluent limitation in this Order (40 mg/L) is arguably less stringent than the weekly average BOD<sub>5</sub> effluent limitation in the previous order (also 40 mg/L). However, because the Facility treatment processes will not change, and because the Facility will continue to provide secondary treatment, no change in effluent quality is expected. More importantly, even if a minor change in effluent quality were to occur, it would not degrade Old Alameda Creek water quality because discharges will be very infrequent and occur only during wet weather when Old Alameda Creek flows are relatively high.

The removal of the average monthly percent removal requirement for CBOD<sub>5</sub> and TSS will not result in a decrease in effluent quality because the Facility's treatment processes will not change. NPDES Permit No. CA0037869 (for the EBDA common outfall) contains average monthly percent removal requirements that ensure that the Facility will continue to meet the Secondary Treatment Standards.

This Order does not retain the maximum discharge flow limitation of 8.4 MG per discharge event. The previous order's basis for the 8.4 MG limitation was the expected flow from a storm with a 20-year return frequency (i.e., a 20-year storm) as determined from the Discharger's 1994 *District Wide Master Plan* and 1999 *Wastewater Equalization Storage Facilities Pre-Design*. Because the purpose of this Order is to regulate discharges during peak wet weather events, discharges covered will involve those from more intense storms with longer return frequencies (e.g., 25-year or 100-year storms). This Order replaces the discharge flow limitation of 8.4 MG with a standard prohibition against the bypass of treatment systems (see Discharge Prohibition III.C of the Order.)

The removal of the 8.4 MG discharge flow limitation will not degrade Old Alameda Creek water quality because 8.4 MG was the expected maximum discharge flow resulting from a 20-year storm. Peak wet weather discharge flows are expected once every 10 years and will be less than 8.4 MG. Future flows from a 20-year storm are unchanged and will likely not be greater than 8.4 MGD. Discharge flows resulting from more intense storms will not degrade Old Alameda Creek water quality because these discharges will be less frequent than 20-year storms and will occur only during wet weather when Old Alameda Creek flows are already relatively high.

- 3. Stringency of Requirements for Individual Pollutants.** This Order contains both technology-based and WQBELs for individual pollutants. This Order's technology-based requirements implement minimum, applicable federal technology-based requirements. In addition, this Order contains more stringent effluent limitations as necessary to meet water quality standards. Collectively, this Order's restrictions on individual pollutants are no more stringent than required to implement CWA requirements.

This Order's WQBELs have been derived to implement water quality objectives that protect beneficial uses. The beneficial uses and water quality objectives have been approved pursuant to federal law and are the applicable federal water quality standards. To the extent that WQBELs were derived from the CTR, the CTR is the applicable standard pursuant to

40 C.F.R. section 131.38. The procedures for calculating these WQBELs are based on the CTR, as implemented in accordance with the SIP, which U.S. EPA approved on May 18, 2000. U.S. EPA approved most Basin Plan beneficial uses and water quality objectives prior to May 30, 2000. Beneficial uses and water quality objectives submitted to U.S. EPA prior to May 30, 2000, but not approved by U.S. EPA before that date, are nonetheless “applicable water quality standards for purposes of the CWA” pursuant to 40 C.F.R. section 131.21(c)(1). U.S. EPA approved the remaining beneficial uses and water quality objectives so they are applicable water quality standards pursuant to 40 C.F.R. section 131.21(c)(2).

## **V. RATIONALE FOR RECEIVING WATER LIMITATIONS**

The receiving water limitations in sections V.A and V.B of the Order are based on Basin Plan narrative and numeric water quality objectives. The receiving water limitation in section V.C of the Order requires compliance with federal and State water quality standards in accordance with the CWA and regulations adopted thereunder.

## **VI. RATIONALE FOR PROVISIONS**

### **A. Standard Provisions**

Attachment D contains standard provisions that apply to all NPDES permits in accordance with 40 C.F.R. section 122.41 and additional conditions applicable to specific categories of permits in accordance with 40 C.F.R. section 122.42. The Discharger must comply with these provisions. The conditions set forth in 40 C.F.R. sections 122.41(a)(1) and (b) through (n) apply to all state-issued NPDES permits and must be incorporated into the permits either expressly or by reference.

In accordance with 40 C.F.R. section 123.25(a)(12), states may omit or modify conditions to impose more stringent requirements. Attachment G contains standard provisions that supplement the federal standard provisions in Attachment D. This Order omits federal conditions that address enforcement authority specified in 40 C.F.R. sections 122.41(j)(5) and (k)(2) because the State’s enforcement authority under the Water Code is more stringent. In lieu of these conditions, this Order incorporates Water Code section 13387(e) by reference.

### **B. Monitoring and Reporting**

CWA section 308 and 40 C.F.R. sections 122.41(h), 122.41(j)-(l), 122.44(i), and 122.48 require that NPDES permits specify monitoring and reporting requirements. Water Code sections 13267 and 13383 also authorize the Regional Water Board to establish monitoring, inspection, entry, reporting, and recordkeeping requirements. The Monitoring and Reporting Program (Attachment E) establishes monitoring, reporting, and recordkeeping requirements that implement federal and State requirements. For more background regarding these requirements, see Fact Sheet section VII.

### **C. Special Provisions**

In addition to the special provisions listed below, the Discharger is subject to special provisions that require best management practices and a pollution minimization program, a pretreatment

program, sludge and biosolids management, and sewer system management as specified in NPDES Permit No. CA0037869 for the EBDA common outfall.

### **1. Reopener Provisions**

These provisions are based on 40 C.F.R. sections 122.62 and 122.63 and allow modification of this Order and its effluent limitations as necessary in response to updated water quality objectives, regulations, or other new and relevant information that may become available in the future, and other circumstances as allowed by law.

### **2. Effluent Characterization Study and Report**

This Order does not include effluent limitations for pollutants that do not demonstrate reasonable potential, but this provision requires the Discharger to continue monitoring for these pollutants as described in the MRP and Attachment G. Monitoring data are necessary to verify that the “no” and “unknown” reasonable potential analysis conclusions of this Order remain valid. This requirement is authorized pursuant to Water Code section 13267 and is necessary to inform the next permit reissuance and to ensure that the Discharger takes timely steps in response to any unanticipated change in effluent quality during the term of this Order.

### **3. Receiving Water Characterization Study and Report**

This Order does not include effluent limitations for pollutants that do not demonstrate reasonable potential, but this provision requires the Discharger to continue monitoring for these pollutants as described in the MRP and Attachment G. Monitoring data are necessary to verify that the “no” and “unknown” reasonable potential analysis conclusions of this Order remain valid. This requirement is authorized pursuant to Water Code section 13267 and is necessary to inform the next permit reissuance.

### **4. Pollutant Minimization Program**

This provision is based on SIP section 2.4.5.

## **VII. RATIONALE FOR MONITORING AND REPORTING PROGRAM**

Attachment E contains the MRP for this Order, which specifies sampling stations, pollutants to be monitored (including all parameters for which effluent limitations are specified), monitoring frequencies, and reporting requirements. The following provides the rationale for the MRP requirements:

### **A. MRP Requirements Rationale**

- 1. Effluent Monitoring.** Effluent monitoring at Monitoring Location M-002D is necessary to evaluate compliance with most of this Order’s effluent limitations and to conduct future reasonable potential analyses. Effluent monitoring at Monitoring Location EFF-WW is necessary to evaluate compliance with Discharge Prohibition III.B (discharge during peak wet weather) and Discharge Prohibition III.C (discharge during discharge flap gate exercises) and to evaluate compliance with this Order’s total chlorine residual effluent limitation (the



Discharger dechlorinates the effluent after it passes Monitoring Location M-002D but before discharge to Old Alameda Creek).

The allowance for determining false positives for chlorine residual when using continuous devices is based on the fact that continuous instruments occasionally have anomalous spikes, and it is chemically improbable to have free chlorine present in the presence of sodium bisulfite. The allowance for using only on-the-hour measurements for mandatory minimum penalty assessment purposes under Water Code section 13385.1 is based on a 2004 strategy developed between the Regional Water Board and the Bay Area Clean Water Agencies.

- 2. Receiving Water Monitoring.** Receiving water monitoring is necessary to conduct future reasonable potential analyses. Monitoring at Monitoring Location RSW-001 is necessary to ascertain background conditions. Monitoring at Monitoring Location RSW-002 is necessary to ascertain the effect of the discharge on Old Alameda Creek and to evaluate compliance with this Order’s receiving water limitations. Hardness monitoring is necessary to calculate applicable water quality objectives. Temperature, salinity, and pH monitoring is necessary to estimate un-ionized ammonia concentrations from total ammonia measurements.

**B. Monitoring Requirements Summary.** The table below summarizes routine monitoring requirements. This table is for informational purposes only. The actual requirements are specified in the MRP and elsewhere in this Order.

**Table F-7. Monitoring Requirements Summary**

Parameter	Effluent M-002D	Effluent EFF-WW	Receiving Water RSW-001	Receiving Water RSW-002
Carbonaceous Biochemical Oxygen Demand (5-day @ 20°C) (CBOD <sub>5</sub> )	1/Discharge <sup>[1]</sup>	---	---	---
Total Suspended Solids (TSS)	1/Discharge <sup>[1]</sup>	---	---	---
Oil and Grease	1/Discharge <sup>[1]</sup>	---	----	---
pH	1/Discharge <sup>[1]</sup>	---	Once	---
Lead, Total	1/Discharge <sup>[1]</sup>	---	---	Once <sup>[2]</sup>
Fecal Coliform	1/Discharge	---	---	---
Ammonia, Total	1/Discharge <sup>[1]</sup>	---	Once	---
Temperature	1/Discharge <sup>[1]</sup>	---	Once	---
Total Residual Chlorine	---	Once every two hours during discharge	---	---
Discharge Duration	---	1/Discharge	---	---
Discharge Volume	---	Continuous/D or 1/Discharge	---	---
Standard Observations	---	---	1/Discharge	---
Salinity	---	---	Once	---
Hardness	---	---	Once	---
Dissolved Oxygen	---	---	Once	---
Other priority pollutants	Once <sup>[2]</sup>	---	---	Once <sup>[2]</sup>

Abbreviations:

Continuous/D = measured continuously, and recorded and reported daily  
1/Discharge = once per discharge event

Footnotes:

- <sup>[1]</sup> Monitoring is not required during discharge flap gate exercises.  
<sup>[2]</sup> Provisions VI.C.2 and VI.C.3 of the Order require this monitoring.

## VIII. PUBLIC PARTICIPATION

The Regional Water Board considered the issuance of WDRs that will serve as an NPDES permit for the Facility. As a step in the WDR adoption process, Regional Water Board staff developed tentative WDRs and encouraged public participation in the WDR adoption process.

- A. Notification of Interested Parties.** The Regional Water Board notified the Discharger and interested agencies and persons of its intent to prescribe WDRs for the discharge and provided an opportunity to submit written comments and recommendations. Notification was provided through *The Argus*. The public had access to the agenda and any changes in dates and locations through the Regional Water Board's website at <http://www.waterboards.ca.gov/sanfranciscobay>.
- B. Written Comments.** Interested persons were invited to submit written comments concerning the tentative WDRs as explained through the notification process. Comments were to be submitted either in person or by mail to the Executive Officer at the Regional Water Board at 1515 Clay Street, Suite 1400, Oakland, California 94612, Attention: James Parrish.

For full staff response and Regional Water Board consideration, the written comments were due at the Regional Water Board office by 5:00 p.m. on October 19, 2015.

- C. Public Hearing.** The Regional Water Board held a public hearing on the tentative WDRs during its regular meeting at the following date and time, and at the following location:

Date: **November 18, 2015**  
Time: 9:00 a.m.  
Location: Elihu Harris State Office Building  
1515 Clay Street, 1<sup>st</sup> Floor Auditorium  
Oakland, CA 94612  
Contact: James Parrish, (510) 622- 2381, [James.Parrish@waterboards.ca.gov](mailto:James.Parrish@waterboards.ca.gov).

Interested persons were invited to attend. At the public hearing, the Regional Water Board heard testimony pertinent to the discharge, WDRs, and permit. For accuracy of the record, important testimony was requested to be in writing.

Dates and venues change. The Regional Water Board web address is <http://www.waterboards.ca.gov/sanfranciscobay>, where one could access the current agenda for changes in dates and locations.

- D. Reconsideration of Waste Discharge Requirements.** Any aggrieved person may petition the State Water Board to review the Regional Water Board decision regarding the final WDRs. The State Water Board must receive the petition at the following address within 30 calendar days of the Regional Water Board action:

State Water Resources Control Board  
Office of Chief Counsel  
P.O. Box 100, 1001 I Street  
Sacramento, CA 95812-0100

For instructions on how to file a petition for review, see  
[http://www.waterboards.ca.gov/public\\_notices/petitions/water\\_quality/wqpetition\\_instr.shtml](http://www.waterboards.ca.gov/public_notices/petitions/water_quality/wqpetition_instr.shtml).

- E. Information and Copying.** The Report of Waste Discharge, related supporting documents, and comments received are on file and may be inspected at the address above at any time between 9:00 a.m. and 5:00 p.m., Monday through Friday. Copying of documents may be arranged by calling (510) 622-2300.
- F. Register of Interested Persons.** Any person interested in being placed on the mailing list for information regarding the WDRs and NPDES permit should contact the Regional Water Board, reference the Facility, and provide a name, address, and phone number.
- G. Additional Information.** Requests for additional information or questions regarding this Order should be directed to James Parrish, at (510) 622- 2381 or [James.Parrish@waterboards.ca.gov](mailto:James.Parrish@waterboards.ca.gov).

**CALIFORNIA REGIONAL WATER QUALITY CONTROL BOARD  
SAN FRANCISCO BAY REGION**

**ATTACHMENT G  
REGIONAL STANDARD PROVISIONS, AND MONITORING  
AND REPORTING REQUIREMENTS  
(SUPPLEMENT TO ATTACHMENT D)**

For

**NPDES WASTEWATER DISCHARGE PERMITS**

March 2010

## Contents

<b>I. STANDARD PROVISIONS - PERMIT COMPLIANCE.....</b>	<b>G-1</b>
A. Duty to Comply .....	G-1
B. Need to Halt or Reduce Activity Not a Defense .....	G-1
C. Duty to Mitigate .....	G-1
1. Contingency Plan .....	G-1
2. Spill Prevention Plan.....	G-2
D. Proper Operation & Maintenance.....	G-2
1. Operation and Maintenance (O&M) Manual.....	G-2
2. Wastewater Facilities Status Report .....	G-2
3. Proper Supervision and Operation of Publicly Owned Treatment Works (POTWs) .....	G-3
E. Property Rights.....	G-3
F. Inspection and Entry.....	G-3
G. Bypass .....	G-3
H. Upset.....	G-3
I. Other .....	G-3
J. Storm water .....	G-3
1. Storm water Pollution Prevention Plan (SWPP Plan).....	G-3
2. Source Identification.....	G-4
3. Storm water Management Controls .....	G-5
4. Annual Verification of SWPP Plan.....	G-6
K. Biosolids Management .....	G-6
<b>II. STANDARD PROVISIONS – PERMIT ACTION.....</b>	<b>G-7</b>
<b>III. STANDARD PROVISIONS – MONITORING .....</b>	<b>G-7</b>
A. Sampling and Analyses .....	G-7
1. Use of Certified Laboratories.....	G-7
2. Use of Appropriate Minimum Levels .....	G-7
3. Frequency of Monitoring .....	G-7
B. Biosolids Monitoring.....	G-10
1. Biosolids Monitoring Frequency .....	G-10
2. Biosolids Pollutants to Monitor .....	G-10
C. Standard Observations.....	G-10
1. Receiving Water Observations .....	G-10
2. Wastewater Effluent Observations .....	G-11
3. Beach and Shoreline Observations .....	G-11
4. Land Retention or Disposal Area Observations.....	G-11
5. Periphery of Waste Treatment and/or Disposal Facilities Observations .....	G-12
<b>IV. STANDARD PROVISIONS – RECORDS .....</b>	<b>G-12</b>
A. Records to be Maintained.....	G-12
B. Records of monitoring information .....	G-12
1. Analytical Information.....	G-12
2. Flow Monitoring Data.....	G-12
3. Wastewater Treatment Process Solids .....	G-13
4. Disinfection Process.....	G-13
5. Treatment Process Bypasses .....	G-13
6. Treatment Facility Overflows .....	G-14
C. Claims of Confidentiality .....	G-14
<b>V. STANDARD PROVISIONS – REPORTING .....</b>	<b>G-14</b>
A. Duty to Provide Information .....	G-14

B. Signatory and Certification Requirements .....G-14  
C. Monitoring Reports .....G-14  
    1. Self Monitoring Reports .....G-14  
D. Compliance Schedules .....G-18  
E. Twenty-Four Hour Reporting .....G-18  
    1. Spill of Oil or Other Hazardous Material Reports .....G-18  
    2. Unauthorized Discharges from Municipal Wastewater Treatment Plants .....G-19  
F. Planned Changes .....G-22  
G. Anticipated Noncompliance .....G-22  
H. Other Noncompliance.....G-22  
I. Other Information.....G-22  
**VI. STANDARD PROVISION – ENFORCEMENT ..... G-22**  
**VII. ADDITIONAL PROVISIONS – NOTIFICATION LEVELS ..... G-22**  
**VIII. DEFINITIONS ..... G-22**

**CALIFORNIA REGIONAL WATER QUALITY CONTROL BOARD  
SAN FRANCISCO BAY REGION**

**REGIONAL STANDARD PROVISIONS, AND MONITORING AND  
REPORTING REQUIREMENTS  
(SUPPLEMENT TO ATTACHMENT D)**

**FOR**

**NPDES WASTEWATER DISCHARGE PERMITS**

**APPLICABILITY**

This document applies to dischargers covered by a National Pollutant Discharge Elimination System (NPDES) permit. This document does not apply to Municipal Separate Storm Sewer System (MS4) NPDES permits.

The purpose of this document is to supplement the requirements of Attachment D, Standard Provisions. The requirements in this supplemental document are designed to ensure permit compliance through preventative planning, monitoring, recordkeeping, and reporting. In addition, this document requires proper characterization of issues as they arise, and timely and full responses to problems encountered. To provide clarity on which sections of Attachment D this document supplements, this document is arranged in the same format as Attachment D.

**I. STANDARD PROVISIONS - PERMIT COMPLIANCE**

**A. Duty to Comply** – Not Supplemented

**B. Need to Halt or Reduce Activity Not a Defense** – Not Supplemented

**C. Duty to Mitigate** – This supplements I.C. of Standard Provisions (Attachment D)

- 1. Contingency Plan** - The Discharger shall maintain a Contingency Plan as originally required by Regional Water Board Resolution 74-10 and as prudent in accordance with current municipal facility emergency planning. The Contingency Plan shall describe procedures to ensure that existing facilities remain in, or are rapidly returned to, operation in the event of a process failure or emergency incident, such as employee strike, strike by suppliers of chemicals or maintenance services, power outage, vandalism, earthquake, or fire. The Discharger may combine the Contingency Plan and Spill Prevention Plan into one document. Discharge in violation of the permit where the Discharger has failed to develop and implement a Contingency Plan as described below will be the basis for considering the discharge a willful and negligent violation of the permit pursuant to California Water Code Section 13387. The Contingency Plan shall, at a minimum, contain the provisions of a. through g. below.
  - a. Provision of personnel for continued operation and maintenance of sewerage facilities during employee strikes or strikes against contractors providing services.

- b. Maintenance of adequate chemicals or other supplies and spare parts necessary for continued operations of sewerage facilities.
  - c. Provisions of emergency standby power.
  - d. Protection against vandalism.
  - e. Expeditious action to repair failures of, or damage to, equipment and sewer lines.
  - f. Report of spills and discharges of untreated or inadequately treated wastes, including measures taken to clean up the effects of such discharges.
  - g. Programs for maintenance, replacement, and surveillance of physical condition of equipment, facilities, and sewer lines.
2. **Spill Prevention Plan** - The Discharger shall maintain a Spill Prevention Plan to prevent accidental discharges and minimize the effects of such events. The Spill Prevention Plan shall:
- a. Identify the possible sources of accidental discharge, untreated or partially treated waste bypass, and polluted drainage;
  - b. Evaluate the effectiveness of present facilities and procedures, and state when they became operational; and
  - c. Predict the effectiveness of the proposed facilities and procedures, and provide an implementation schedule containing interim and final dates when they will be constructed, implemented, or operational.

This Regional Water Board, after review of the Contingency and Spill Prevention Plans or their updated revisions, may establish conditions it deems necessary to control accidental discharges and to minimize the effects of such events. Such conditions may be incorporated as part of the permit upon notice to the Discharger.

**D. Proper Operation & Maintenance** – This supplements I.D of Standard Provisions (Attachment D)

1. **Operation and Maintenance (O&M) Manual** - The Discharger shall maintain an O&M Manual to provide the plant and regulatory personnel with a source of information describing all equipment, recommended operational strategies, process control monitoring, and maintenance activities. To remain a useful and relevant document, the O&M Manual shall be kept updated to reflect significant changes in treatment facility equipment and operational practices. The O&M Manual shall be maintained in usable condition and be available for reference and use by all relevant personnel and Regional Water Board staff.
2. **Wastewater Facilities Status Report** - The Discharger shall regularly review, revise, or update, as necessary, its Wastewater Facilities Status Report. This report shall document how the Discharger operates and maintains its wastewater collection, treatment, and disposal facilities to ensure that all facilities are adequately staffed, supervised, financed, operated, maintained, repaired, and upgraded as necessary to provide adequate and reliable transport, treatment, and disposal of all wastewater from both existing and planned future wastewater sources under the Discharger's service responsibilities.



3. Proper Supervision and Operation of Publicly Owned Treatment Works (POTWs) - POTWs shall be supervised and operated by persons possessing certificates of appropriate grade pursuant to Division 4, Chapter 14, Title 23 of the California Code of Regulations.

**E. Property Rights** – Not Supplemented

**F. Inspection and Entry** – Not Supplemented

**G. Bypass** – Not Supplemented

**H. Upset** – Not Supplemented

**I. Other** – This section is an addition to Standard Provisions (Attachment D)

1. Neither the treatment nor the discharge of pollutants shall create pollution, contamination, or nuisance as defined by California Water Code Section 13050.
2. Collection, treatment, storage, and disposal systems shall be operated in a manner that precludes public contact with wastewater, except in cases where excluding the public is infeasible, such as private property. If public contact with wastewater could reasonably occur on public property, warning signs shall be posted.
3. If the Discharger submits a timely and complete Report of Waste Discharge for permit reissuance, this permit continues in force and effect until a new permit is issued or the Regional Water Board rescinds the permit.

**J. Storm Water** – This section is an addition to Standard Provisions (Attachment D)

These provisions apply to facilities that do not direct all storm water flows from the facility to the wastewater treatment plant headworks.

**1. Storm Water Pollution Prevention Plan (SWPP Plan)**

The SWPP Plan shall be designed in accordance with good engineering practices and shall address the following objectives:

- a. To identify pollutant sources that may affect the quality of storm water discharges; and
- b. To identify, assign, and implement control measures and management practices to reduce pollutants in storm water discharges.

The SWPP Plan may be combined with the existing Spill Prevention Plan as required in accordance with Section C.2. The SWPP Plan shall be retained on-site and made available upon request of a representative of the Regional Water Board.

## 2. Source Identification

The SWPP Plan shall provide a description of potential sources that may be expected to add significant quantities of pollutants to storm water discharges, or may result in non-storm water discharges from the facility. The SWPP Plan shall include, at a minimum, the following items:

- a. A topographical map (or other acceptable map if a topographical map is unavailable), extending one-quarter mile beyond the property boundaries of the facility, showing the wastewater treatment facility process areas, surface water bodies (including springs and wells), and discharge point(s) where the facility's storm water discharges to a municipal storm drain system or other points of discharge to waters of the State. The requirements of this paragraph may be included in the site map required under the following paragraph if appropriate.
- b. A site map showing the following:
  - 1) Storm water conveyance, drainage, and discharge structures;
  - 2) An outline of the storm water drainage areas for each storm water discharge point;
  - 3) Paved areas and buildings;
  - 4) Areas of actual or potential pollutant contact with storm water or release to storm water, including but not limited to outdoor storage and process areas; material loading, unloading, and access areas; and waste treatment, storage, and disposal areas;
  - 5) Location of existing storm water structural control measures (i.e., berms, coverings, etc.);
  - 6) Surface water locations, including springs and wetlands; and
  - 7) Vehicle service areas.
- c. A narrative description of the following:
  - 1) Wastewater treatment process activity areas;
  - 2) Materials, equipment, and vehicle management practices employed to minimize contact of significant materials of concern with storm water discharges;
  - 3) Material storage, loading, unloading, and access areas;
  - 4) Existing structural and non-structural control measures (if any) to reduce pollutants in storm water discharges; and
  - 5) Methods of on-site storage and disposal of significant materials.
- d. A list of pollutants that have a reasonable potential to be present in storm water discharges in significant quantities.

### 3. Storm Water Management Controls

The SWPP Plan shall describe the storm water management controls appropriate for the facility and a time schedule for fully implementing such controls. The appropriateness and priorities of controls in the SWPP Plan shall reflect identified potential sources of pollutants. The description of storm water management controls to be implemented shall include, as appropriate:

a. Storm water pollution prevention personnel

Identify specific individuals (and job titles) that are responsible for developing, implementing, and reviewing the SWPP Plan.

b. Good housekeeping

Good housekeeping requires the maintenance of clean, orderly facility areas that discharge storm water. Material handling areas shall be inspected and cleaned to reduce the potential for pollutants to enter the storm drain conveyance system.

c. Spill prevention and response

Identify areas where significant materials can spill into or otherwise enter storm water conveyance systems and their accompanying drainage points. Specific material handling procedures, storage requirements, and cleanup equipment and procedures shall be identified, as appropriate. The necessary equipment to implement a cleanup shall be available, and personnel shall be trained in proper response, containment, and cleanup of spills. Internal reporting procedures for spills of significant materials shall be established.

d. Source control

Source controls include, for example, elimination or reduction of the use of toxic pollutants, covering of pollutant source areas, sweeping of paved areas, containment of potential pollutants, labeling of all storm drain inlets with “No Dumping” signs, isolation or separation of industrial and non-industrial pollutant sources so that runoff from these areas does not mix, etc.

e. Storm water management practices

Storm water management practices are practices other than those that control the sources of pollutants. Such practices include treatment or conveyance structures, such as drop inlets, channels, retention and detention basins, treatment vaults, infiltration galleries, filters, oil/water separators, etc. Based on assessment of the potential of various sources to contribute pollutants to storm water discharges in significant quantities, additional storm water management practices to remove pollutants from storm water discharges shall be implemented and design criteria shall be described.

f. Sediment and erosion control

Measures to minimize erosion around the storm water drainage and discharge points, such as riprap, revegetation, slope stabilization, etc., shall be described.

g. Employee training

Employee training programs shall inform all personnel responsible for implementing the SWPP Plan. Training shall address spill response, good housekeeping, and material management practices. New employee and refresher training schedules shall be identified.

h. Inspections

All inspections shall be done by trained personnel. Material handling areas shall be inspected for evidence of, or the potential for, pollutants entering storm water discharges. A tracking or follow up procedure shall be used to ensure appropriate response has been taken in response to an inspection. Inspections and maintenance activities shall be documented and recorded. Inspection records shall be retained for five years.

i. Records

A tracking and follow-up procedure shall be described to ensure that adequate response and corrective actions have been taken in response to inspections.

**4. Annual Verification of SWPP Plan**

An annual facility inspection shall be conducted to verify that all elements of the SWPP Plan are accurate and up-to-date. The results of this review shall be reported in the Annual Report to the Regional Water Board described in Section V.C.f.

**K. Biosolids Management** – This section is an addition to Standard Provisions (Attachment D)

Biosolids must meet the following requirements prior to land application. The Discharger must either demonstrate compliance or, if it sends the biosolids to another party for further treatment or distribution, must give the recipient the information necessary to ensure compliance.

1. Exceptional quality biosolids meet the pollutant concentration limitations in Table III of 40 C.F.R. Part 503.13, Class A pathogen limitations, and one of the vector attraction reduction requirements in 503.33(b)(1)-(b)(8). Such biosolids do not have to be tracked further for compliance with general requirements (503.12) and management practices (503.14).
2. Biosolids used for agricultural land, forest, or reclamation shall meet the pollutant limitations in Table I (ceiling concentrations) and Table II or Table III (cumulative loadings or pollutant concentration limitations) of 503.13. They shall also meet the general requirements (503.12) and management practices (503.14) (if not exceptional quality biosolids) for Class A or Class B pathogen levels with associated access restrictions (503.32) and one of the 10 vector attraction reduction requirements in 503.33(b)(1)-(b)(10).
3. Biosolids used for lawn or home gardens must meet exceptional quality biosolids limitations.
4. Biosolids sold or given away in a bag or other container must meet the pollutant limitations in either Table III or Table IV (pollutant concentration limitations or annual pollutant loading rate limitations) of 503.13. If Table IV is used, a label or information sheet must be attached to the biosolids packing that explains Table IV (see 503.14). The biosolids must also meet the Class A pathogen limitations and one of the vector attraction reduction requirements in 503.33(b)(1)-(b)(8).

**II. STANDARD PROVISIONS – PERMIT ACTION** – Not Supplemented

### III. STANDARD PROVISIONS – MONITORING

#### A. Sampling and Analyses – This section is a supplement to III.A and III.B of Standard Provisions (Attachment D)

##### 1. Use of Certified Laboratories

Water and waste analyses shall be performed by a laboratory certified for these analyses in accordance with California Water Code Section 13176.

##### 2. Use of Appropriate Minimum Levels

Table C lists the suggested analytical methods for the 126 priority pollutants and other toxic pollutants that should be used, unless a particular method or minimum level (ML) is required in the MRP.

For priority pollutant monitoring, when there is more than one ML value for a given substance, the Discharger may select any one of the analytical methods cited in Table C for compliance determination, or any other method described in 40 C.F.R. part 136 or approved by U.S. EPA (such as the 1600 series) if authorized by the Regional Water Board. However, the ML must be below the effluent limitation and water quality objective. If no ML value is below the effluent limitation and water quality objective, then the method must achieve an ML no greater than the lowest ML value indicated in Table C. All monitoring instruments and equipment shall be properly calibrated and maintained to ensure accuracy of measurements.

##### 3. Frequency of Monitoring

The minimum schedule of sampling analysis is specified in the MRP portion of the permit.

###### a. Timing of Sample Collection

- 1) The Discharger shall collect samples of influent on varying days selected at random and shall not include any plant recirculation or other sidestream wastes, unless otherwise stipulated by the MRP.
- 2) The Discharger shall collect samples of effluent on days coincident with influent sampling unless otherwise stipulated by the MRP or the Executive Officer. The Executive Officer may approve an alternative sampling plan if it is demonstrated to be representative of plant discharge flow and in compliance with all other permit requirements.
- 3) The Discharger shall collect grab samples of effluent during periods of day-time maximum peak effluent flows (or peak flows through secondary treatment units for facilities that recycle effluent flows).
- 4) Effluent sampling for conventional pollutants shall occur on at least one day of any multiple-day bioassay test the MRP requires. During the course of the test, on at least one day, the Discharger shall collect and retain samples of the discharge. In the event a bioassay test does

not comply with permit limitations, the Discharger shall analyze these retained samples for pollutants that could be toxic to aquatic life and for which it has effluent limitations.

- i. The Discharger shall perform bioassay tests on final effluent samples; when chlorine is used for disinfection, bioassay tests shall be performed on effluent after chlorination-dechlorination; and
- ii. The Discharger shall analyze for total ammonia nitrogen and calculate the amount of un-ionized ammonia whenever test results fail to meet the percent survival specified in the permit.

b. Conditions Triggering Accelerated Monitoring

- 1) If the results from two consecutive samples of a constituent monitored in a 30-day period exceed the monthly average limit for any parameter (or if the required sampling frequency is once per month and the monthly sample exceeds the monthly average limit), the Discharger shall, within 24 hours after the results are received, increase its sampling frequency to daily until the results from the additional sampling show that the parameter is in compliance with the monthly average limit.
- 2) If any maximum daily limit is exceeded, the Discharger shall increase its sampling frequency to daily within 24 hours after the results are received that indicate the exceedance of the maximum daily limit until two samples collected on consecutive days show compliance with the maximum daily limit.
- 3) If final or intermediate results of an acute bioassay test indicate a violation or threatened violation (e.g., the percentage of surviving test organisms of any single acute bioassay test is less than 70 percent), the Discharger shall initiate a new test as soon as practical, and the Discharger shall investigate the cause of the mortalities and report its findings in the next self monitoring report (SMR).
- 4) The Discharger shall calibrate chlorine residual analyzers against grab samples as frequently as necessary to maintain accurate control and reliable operation. If an effluent violation is detected, the Discharger shall collect grab samples at least every 30 minutes until compliance with the limit is achieved, unless the Discharger monitors chlorine residual continuously. In such cases, the Discharger shall continue to conduct continuous monitoring as required by its permit.
- 5) When a bypass occurs (except one subject to provision III.A.3.b.6 below), the Discharger shall monitor flows and collect samples on a daily basis for all constituents at affected discharge points that have effluent limitations for the duration of the bypass (including acute toxicity using static renewals), except chronic toxicity, unless otherwise stipulated by the MRP.
- 6) Unless otherwise stipulated by the MRP, when a bypass approved pursuant to Attachment D, Standard Provisions, Sections I.G.2 or I.G.4, occurs, the Discharger shall monitor flows and, using appropriate procedures as specified in the MRP, collect and retain samples for affected discharge points on a daily basis for the duration of the bypass. The Discharger shall analyze for total suspended solids (TSS) using 24-hour composites (or more frequent increments) and for bacteria indicators with effluent limitations using grab samples. If TSS exceeds 45 mg/L in any composite sample, the Discharger shall also analyze the retained samples for that discharge for all other constituents that have effluent limitations, except oil and grease,

mercury, dioxin-TEQ, and acute and chronic toxicity. Additionally, at least once each year, the Discharger shall analyze the retained samples for one approved bypass discharge event for all other constituents that have effluent limitations, except oil and grease, mercury, dioxin-TEQ, and acute and chronic toxicity. This monitoring shall be in addition to the minimum monitoring specified in the MRP.

c. Storm Water Monitoring

The requirements of this section only apply to facilities that are not covered by an NPDES permit for storm water discharges and where not all site storm drainage from process areas (i.e., areas of the treatment facility where chemicals or wastewater could come in contact with storm water) is directed to the headworks. For storm water not directed to the headworks during the wet season (October 1 to April 30), the Discharger shall:

- 1) Conduct visual observations of the storm water discharge locations during daylight hours at least once per month during a storm event that produces significant storm water discharge to observe the presence of floating and suspended materials, oil and grease, discoloration, turbidity, and odor, etc.
- 2) Measure (or estimate) the total volume of storm water discharge, collect grab samples of storm water discharge from at least two storm events that produce significant storm water discharge, and analyze the samples for oil and grease, pH, TSS, and specific conductance.

The grab samples shall be taken during the first 30 minutes of the discharge. If collection of the grab samples during the first 30 minutes is impracticable, grab samples may be taken during the first hour of the discharge, and the Discharger shall explain in the Annual Report why the grab sample(s) could not be taken in the first 30 minutes.

- 3) Testing for the presence of non-storm water discharges shall be conducted no less than twice during the dry season (May 1 to September 30) at all storm water discharge locations. Tests may include visual observations of flows, stains, sludges, odors, and other abnormal conditions; dye tests; TV line surveys; or analysis and validation of accurate piping schematics. Records shall be maintained describing the method used, date of testing, locations observed, and test results.
- 4) Samples shall be collected from all locations where storm water is discharged. Samples shall represent the quality and quantity of storm water discharged from the facility. If a facility discharges storm water at multiple locations, the Discharger may sample a reduced number of locations if it establishes and documents through the monitoring program that storm water discharges from different locations are substantially identical.
- 5) Records of all storm water monitoring information and copies of all reports required by the permit shall be retained for a period of at least three years from the date of sample, observation, or report.

d. Receiving Water Monitoring

The requirements of this section only apply when the MRP requires receiving water sampling.

- 1) Receiving water samples shall be collected on days coincident with effluent sampling for conventional pollutants.
- 2) Receiving water samples shall be collected at each station on each sampling day during the period within one hour following low slack water. Where sampling during lower slack water is impractical, sampling shall be performed during higher slack water. Samples shall be collected within the discharge plume and down current of the discharge point so as to be representative, unless otherwise stipulated in the MRP.
- 3) Samples shall be collected within one foot of the surface of the receiving water, unless otherwise stipulated in the MRP.

**B. Biosolids Monitoring** – This section supplements III.B of Standard Provisions (Attachment D)

When biosolids are sent to a landfill, sent to a surface disposal site, or applied to land as a soil amendment, they must be monitored as follows:

**1. Biosolids Monitoring Frequency**

Biosolids disposal must be monitored at the following frequency:

<u>Metric tons biosolids/365 days</u>	<u>Frequency</u>
0-290	Once per year
290-1500	Quarterly
1500-15,000	Six times per year
Over 15,000	Once per month

(Metric tons are on a dry weight basis)

**2. Biosolids Pollutants to Monitor**

Biosolids shall be monitored for the following constituents:

- Land Application: Arsenic, cadmium, copper, mercury, molybdenum, nickel, lead, selenium, and zinc
- Municipal Landfill: Paint filter test (pursuant to 40 C.F.R. 258)
- Biosolids-only Landfill or Surface Disposal Site (if no liner and leachate system): arsenic, chromium, and nickel

**C. Standard Observations** – This section is an addition to III of Standard Provisions (Attachment D)

**1. Receiving Water Observations**

The requirements of this section only apply when the MRP requires standard observations of the receiving water. Standard observations shall include the following:



- a. *Floating and suspended materials* (e.g., oil, grease, algae, and other macroscopic particulate matter): presence or absence, source, and size of affected area.
- b. *Discoloration and turbidity*: description of color, source, and size of affected area.
- c. *Odor*: presence or absence, characterization, source, distance of travel, and wind direction.
- d. *Beneficial water use*: presence of water-associated waterfowl or wildlife, fisherpeople, and other recreational activities in the vicinity of each sampling station.
- e. *Hydrographic condition*: time and height of corrected high and low tides (corrected to nearest National Oceanic and Atmospheric Administration location for the sampling date and time of sample collection).
- f. *Weather conditions*:
  - 1) Air temperature; and
  - 2) Total precipitation during the five days prior to observation.

## 2. Wastewater Effluent Observations

The requirements of this section only apply when the MRP requires wastewater effluent standard observations. Standard observations shall include the following:

- a. *Floating and suspended material of wastewater origin* (e.g., oil, grease, algae, and other macroscopic particulate matter): presence or absence.
- b. *Odor*: presence or absence, characterization, source, distance of travel, and wind direction.

## 3. Beach and Shoreline Observations

The requirements of this section only apply when the MRP requires beach and shoreline standard observations. Standard observations shall include the following:

- a. *Material of wastewater origin*: presence or absence, description of material, estimated size of affected area, and source.
- b. *Beneficial use*: estimate number of people participating in recreational water contact, non-water contact, or fishing activities.

## 4. Land Retention or Disposal Area Observations

The requirements of this section only apply to facilities with on-site surface impoundments or disposal areas that are in use. This section applies to both liquid and solid wastes, whether confined or unconfined. The Discharger shall conduct the following for each impoundment:

- a. Determine the amount of freeboard at the lowest point of dikes confining liquid wastes.
- b. Report evidence of leaching liquid from area of confinement and estimated size of affected area. Show affected area on a sketch and volume of flow (e.g., gallons per minute [gpm]).

- c. Regarding odor, describe presence or absence, characterization, source, distance of travel, and wind direction.
- d. Estimate number of waterfowl and other water-associated birds in the disposal area and vicinity.

#### 5. Periphery of Waste Treatment and/or Disposal Facilities Observations

The requirements of this section only apply when the MRP specifies periphery standard observations. Standard observations shall include the following:

- a. *Odor*: presence or absence, characterization, source, and distance of travel.
- b. *Weather conditions*: wind direction and estimated velocity.

### IV. STANDARD PROVISIONS – RECORDS

#### A. Records to be Maintained – This supplements IV.A of Standard Provisions (Attachment D)

The Discharger shall maintain records in a manner and at a location (e.g., wastewater treatment plant or Discharger offices) such that the records are accessible to Regional Water Board staff. The minimum period of retention specified in Section IV, Records, of the Federal Standard Provisions shall be extended during the course of any unresolved litigation regarding the subject discharge, or when requested by the Regional Water Board or Regional Administrator of U.S. EPA, Region IX.

A copy of the permit shall be maintained at the discharge facility and be available at all times to operating personnel.

#### B. Records of monitoring information shall include – This supplements IV.B of Standard Provision (Attachment D)

##### 1. Analytical Information

Records shall include analytical method detection limitations, minimum levels, reporting levels, and related quantification parameters.

##### 2. Flow Monitoring Data

For all required flow monitoring (e.g., influent and effluent flows), the additional records shall include the following, unless otherwise stipulated by the MRP:

- a. Total volume for each day; and
- b. Maximum, minimum, and average daily flows for each calendar month.

### 3. Wastewater Treatment Process Solids

- a. For each treatment unit process that involves solids removal from the wastewater stream, records shall include the following:
  - 1) Total volume or mass of solids removed from each collection unit (e.g., grit, skimmings, undigested biosolids, or combination) for each calendar month or other time period as appropriate, but not to exceed annually; and
  - 2) Final disposition of such solids (e.g., landfill, other subsequent treatment unit).
- b. For final dewatered biosolids from the treatment plant as a whole, records shall include the following:
  - 1) Total volume or mass of dewatered biosolids for each calendar month;
  - 2) Solids content of the dewatered biosolids; and
  - 3) Final disposition of dewatered biosolids (disposal location and disposal method).

### 4. Disinfection Process

For the disinfection process, these additional records shall be maintained documenting process operation and performance:

- a. For bacteriological analyses:
  - 1) Wastewater flow rate at the time of sample collection; and
  - 2) Required statistical parameters for cumulative bacterial values (e.g., moving median or geometric mean for the number of samples or sampling period identified in this Order).
- b. For the chlorination process, when chlorine is used for disinfection, at least daily average values for the following:
  - 1) Chlorine residual of treated wastewater as it enters the contact basin (mg/L);
  - 2) Chlorine dosage (kg/day); and
  - 3) Dechlorination chemical dosage (kg/day).

### 5. Treatment Process Bypasses

A chronological log of all treatment process bypasses, including wet weather blending, shall include the following:

- a. Identification of the treatment process bypassed;
- b. Dates and times of bypass beginning and end;
- c. Total bypass duration;

- d. Estimated total bypass volume; and
- e. Description of, or reference to other reports describing, the bypass event, the cause, the corrective actions taken (except for wet weather blending that is in compliance with permit conditions), and any additional monitoring conducted.

## 6. Treatment Facility Overflows

This section applies to records for overflows at the treatment facility. This includes the headworks and all units and appurtenances downstream. The Discharger shall retain a chronological log of overflows at the treatment facility and records supporting the information provided in section V.E.2.

## C. Claims of Confidentiality – Not Supplemented

# V. STANDARD PROVISIONS – REPORTING

## A. Duty to Provide Information – Not Supplemented

## B. Signatory and Certification Requirements – Not Supplemented

## C. Monitoring Reports – This section supplements V.C of Standard Provisions (Attachment D)

### 1. Self Monitoring Reports

For each reporting period established in the MRP, the Discharger shall submit an SMR to the Regional Water Board in accordance with the requirements listed in this document and at the frequency the MRP specifies. The purpose of the SMR is to document treatment performance, effluent quality, and compliance with the waste discharge requirements of this Order.

#### a. Transmittal letter

Each SMR shall be submitted with a transmittal letter. This letter shall include the following:

- 1) Identification of all violations of effluent limitations or other waste discharge requirements found during the reporting period;
- 2) Details regarding violations: parameters, magnitude, test results, frequency, and dates;
- 3) Causes of violations;
- 4) Discussion of corrective actions taken or planned to resolve violations and prevent recurrences, and dates or time schedule of action implementation (if previous reports have been submitted that address corrective actions, reference to the earlier reports is satisfactory);
- 5) Data invalidation (Data should not be submitted in an SMR if it does not meet quality assurance/quality control standards. However, if the Discharger wishes to invalidate any measurement after it was submitted in an SMR, a letter shall identify the measurement suspected to be invalid and state the Discharger's intent to submit, within 60 days, a formal request to invalidate the measurement. This request shall include the original measurement in question, the reason for invalidating the measurement, all relevant documentation that supports invalidation [e.g., laboratory sheet, log entry, test results, etc.], and discussion of the

corrective actions taken or planned [with a time schedule for completion] to prevent recurrence of the sampling or measurement problem.);

- 6) If the Discharger blends, the letter shall describe the duration of blending events and certify whether blended effluent was in compliance with the conditions for blending; and
- 7) Signature (The transmittal letter shall be signed according to Section V.B of this Order, Attachment D – Standard Provisions.).

b. Compliance evaluation summary

Each report shall include a compliance evaluation summary. This summary shall include each parameter for which the permit specifies effluent limitations, the number of samples taken during the monitoring period, and the number of samples that exceed applicable effluent limitations.

c. Results of analyses and observations

- 1) Tabulations of all required analyses and observations, including parameter, date, time, sample station, type of sample, test result, method detection limit, method minimum level, and method reporting level, if applicable, signed by the laboratory director or other responsible official.
- 2) When determining compliance with an average monthly effluent limitation and more than one sample result is available in a month, the Discharger shall compute the arithmetic mean unless the data set contains one or more reported determinations of detected but not quantified (DNQ) or nondetect (ND). In those cases, the Discharger shall compute the median in place of the arithmetic mean in accordance with the following procedure:
  - i. The data set shall be ranked from low to high, reported ND determinations lowest, DNQ determinations next, followed by quantified values (if any). The order of the individual ND or DNQ determinations is unimportant.
  - ii. The median value of the data set shall be determined. If the data set has an odd number of data points, then the median is the middle value. If the data set has an even number of data points, then the median is the average of the two values around the middle unless one or both of the points are ND or DNQ, in which case the median value shall be the lower of the two data points where DNQ is lower than a value and ND is lower than DNQ.

If a sample result, or the arithmetic mean or median of multiple sample results, is below the reporting limit, and there is evidence that the priority pollutant is present in the effluent above an effluent limitation and the Discharger conducts a Pollutant Minimization Program, the Discharger shall not be deemed out of compliance.

- 3) Dioxin-TEQ Reporting: The Discharger shall report for each dioxin and furan congener the analytical results of effluent monitoring, including the quantifiable limit (reporting level), the method detection limit, and the measured concentration. The Discharger shall report all measured values of individual congeners, including data qualifiers. When calculating dioxin-TEQ, the Discharger shall set congener concentrations below the minimum levels (ML) to zero. The Discharger shall calculate and report dioxin-TEQs using the following formula, where the MLs, toxicity equivalency factors (TEFs), and bioaccumulation equivalency factors (BEFs) are as provided in Table A:

$$\text{Dioxin-TEQ} = \sum (C_x \times \text{TEF}_x \times \text{BEF}_x)$$

where:  $C_x$  = measured or estimated concentration of congener  $x$   
 $\text{TEF}_x$  = toxicity equivalency factor for congener  $x$   
 $\text{BEF}_x$  = bioaccumulation equivalency factor for congener  $x$

**Table A**  
 Minimum Levels, Toxicity Equivalency Factors,  
 and Bioaccumulation Equivalency Factors

Dioxin or Furan Congener	Minimum Level (pg/L)	1998 Toxicity Equivalency Factor (TEF)	Bioaccumulation Equivalency Factor (BEF)
2,3,7,8-TCDD	10	1.0	1.0
1,2,3,7,8-PeCDD	50	1.0	0.9
1,2,3,4,7,8-HxCDD	50	0.1	0.3
1,2,3,6,7,8-HxCDD	50	0.1	0.1
1,2,3,7,8,9-HxCDD	50	0.1	0.1
1,2,3,4,6,7,8-HpCDD	50	0.01	0.05
OCDD	100	0.0001	0.01
2,3,7,8-TCDF	10	0.1	0.8
1,2,3,7,8-PeCDF	50	0.05	0.2
2,3,4,7,8-PeCDF	50	0.5	1.6
1,2,3,4,7,8-HxCDF	50	0.1	0.08
1,2,3,6,7,8-HxCDF	50	0.1	0.2
1,2,3,7,8,9-HxCDF	50	0.1	0.6
2,3,4,6,7,8-HxCDF	50	0.1	0.7
1,2,3,4,6,7,8-HpCDF	50	0.01	0.01
1,2,3,4,7,8,9-HpCDF	50	0.01	0.4
OCDF	100	0.0001	0.02

d. Data reporting for results not yet available

The Discharger shall make all reasonable efforts to obtain analytical data for required parameter sampling in a timely manner. Certain analyses require additional time to complete analytical processes and report results. For cases where required monitoring parameters require additional time to complete analytical processes and reports, and results are not available in time to be included in the SMR for the subject monitoring period, the Discharger shall describe such circumstances in the SMR and include the data for these parameters and relevant discussions of any observed exceedances in the next SMR due after the results are available.

e. Flow data

The Discharger shall provide flow data tabulation pursuant to Section IV.B.2.

f. Annual self monitoring report requirements

By the date specified in the MRP, the Discharger shall submit an annual report to the Regional Water Board covering the previous calendar year. The report shall contain the following:

- 1) Annual compliance summary table of treatment plant performance, including documentation of any blending events;
- 2) Comprehensive discussion of treatment plant performance and compliance with the permit (This discussion shall include any corrective actions taken or planned, such as changes to facility equipment or operation practices that may be needed to achieve compliance, and any other actions taken or planned that are intended to improve performance and reliability of the Discharger's wastewater collection, treatment, or disposal practices.);
- 3) Both tabular and graphical summaries of the monitoring data for the previous year if parameters are monitored at a frequency of monthly or greater;
- 4) List of approved analyses, including the following:
  - (i) List of analyses for which the Discharger is certified;
  - (ii) List of analyses performed for the Discharger by a separate certified laboratory (copies of reports signed by the laboratory director of that laboratory shall not be submitted but be retained onsite); and
  - (iii) List of "waived" analyses, as approved;
- 5) Plan view drawing or map showing the Discharger's facility, flow routing, and sampling and observation station locations;
- 6) Results of annual facility inspection to verify that all elements of the SWPP Plan are accurate and up to date (only required if the Discharger does not route all storm water to the headworks of its wastewater treatment plant); and
- 7) Results of facility report reviews (The Discharger shall regularly review, revise, and update, as necessary, the O&M Manual, the Contingency Plan, the Spill Prevention Plan, and Wastewater Facilities Status Report so that these documents remain useful and relevant to current practices. At a minimum, reviews shall be conducted annually. The Discharger shall include, in each Annual Report, a description or summary of review and evaluation procedures, recommended or planned actions, and an estimated time schedule for implementing these actions. The Discharger shall complete changes to these documents to ensure they are up-to-date.).

g. Report submittal

The Discharger shall submit SMRs to:

California Regional Water Quality Control Board

San Francisco Bay Region  
1515 Clay Street, Suite 1400  
Oakland, CA 94612  
Attn: NPDES Wastewater Division

h. Reporting data in electronic format

The Discharger has the option to submit all monitoring results in an electronic reporting format approved by the Executive Officer. If the Discharger chooses to submit SMRs electronically, the following shall apply:

- 1) *Reporting Method*: The Discharger shall submit SMRs electronically via a process approved by the Executive Officer (see, for example, the letter dated December 17, 1999, "Official Implementation of Electronic Reporting System [ERS]" and the progress report letter dated December 17, 2000).
- 2) *Monthly or Quarterly Reporting Requirements*: For each reporting period (monthly or quarterly as specified in the MRP), the Discharger shall submit an electronic SMR to the Regional Water Board in accordance with the provisions of Section V.C.1.a-e, except for requirements under Section V.C.1.c(1) where ERS does not have fields for dischargers to input certain information (e.g., sample time). However, until U.S. EPA approves the electronic signature or other signature technologies, dischargers that use ERS shall submit a hard copy of the original transmittal letter, an ERS printout of the data sheet, and a violation report (a receipt of the electronic transmittal shall be retained by the Discharger). This electronic SMR submittal suffices for the signed tabulations specified under Section V.C.1.c(1).
- 3) *Annual Reporting Requirements*: Dischargers who have submitted data using the ERS for at least one calendar year are exempt from submitting the portion of the annual report required under Section V.C.1.f(1) and (3).

**D. Compliance Schedules** – Not supplemented

**E. Twenty-Four Hour Reporting** – This section supplements V.E of Standard Provision (Attachment D)

**1. Spill of Oil or Other Hazardous Material Reports**

- a. Within 24 hours of becoming aware of a spill of oil or other hazardous material that is not contained onsite and completely cleaned up, the Discharger shall report by telephone to the Regional Water Board at (510) 622-2369.
- b. The Discharger shall also report such spills to the State Office of Emergency Services [telephone (800) 852-7550] only when the spills are in accordance with applicable reporting quantities for hazardous materials.
- c. The Discharger shall submit a written report to the Regional Water Board within five working days following telephone notification unless directed otherwise by Regional Water Board staff. A report submitted electronically is acceptable. The written report shall include the following:
  - 1) Date and time of spill, and duration if known;



- 2) Location of spill (street address or description of location);
- 3) Nature of material spilled;
- 4) Quantity of material involved;
- 5) Receiving water body affected, if any;
- 6) Cause of spill;
- 7) Estimated size of affected area;
- 8) Observed impacts to receiving waters (e.g., oil sheen, fish kill, water discoloration);
- 9) Corrective actions taken to contain, minimize, or clean up the spill;
- 10) Future corrective actions planned to be taken to prevent recurrence, and schedule of implementation; and
- 11) Persons or agencies notified.

## 2. Unauthorized Discharges from Municipal Wastewater Treatment Plants<sup>1</sup>

The following requirements apply to municipal wastewater treatment plants that experience an unauthorized discharge at their treatment facilities and are consistent with and supercede requirements imposed on the Discharger by the Executive Officer by letter of May 1, 2008, issued pursuant to California Water Code Section 13383.

### a. Two (2)-Hour Notification

For any unauthorized discharges that result in a discharge to a drainage channel or a surface water, the Discharger shall, as soon as possible, but not later than two (2) hours after becoming aware of the discharge, notify the State Office of Emergency Services (telephone 800-852-7550), the local health officers or directors of environmental health with jurisdiction over the affected water bodies, and the Regional Water Board. The notification to the Regional Water Board shall be via the Regional Water Board's online reporting system at [www.wbers.net](http://www.wbers.net), and shall include the following:

- 1) Incident description and cause;
- 2) Location of threatened or involved waterway(s) or storm drains;
- 3) Date and time the unauthorized discharge started;
- 4) Estimated quantity and duration of the unauthorized discharge (to the extent known), and the estimated amount recovered;

---

<sup>1</sup> California Code of Regulations, Title 23, Section 2250(b), defines an unauthorized discharge to be a discharge, not regulated by waste discharge requirements, of treated, partially treated, or untreated wastewater resulting from the intentional or unintentional diversion of wastewater from a collection, treatment or disposal system.

- 5) Level of treatment prior to discharge (e.g., raw wastewater, primary treated, undisinfected secondary treated, and so on); and
- 6) Identity of the person reporting the unauthorized discharge.

b. 24-hour Certification

Within 24 hours, the Discharger shall certify to the Regional Water Board, at [www.wbers.net](http://www.wbers.net), that the State Office of Emergency Services and the local health officers or directors of environmental health with jurisdiction over the affected water bodies have been notified of the unauthorized discharge.

c. 5-Day Written Report

Within five business days, the Discharger shall submit a written report, via the Regional Water Board's online reporting system at [www.wbers.net](http://www.wbers.net), that includes, in addition to the information required above, the following:

- 1) Methods used to delineate the geographical extent of the unauthorized discharge within receiving waters;
- 2) Efforts implemented to minimize public exposure to the unauthorized discharge;
- 3) Visual observations of the impacts (if any) noted in the receiving waters (e.g., fish kill, discoloration of water) and the extent of sampling if conducted;
- 4) Corrective measures taken to minimize the impact of the unauthorized discharge;
- 5) Measures to be taken to minimize the chances of a similar unauthorized discharge occurring in the future;
- 6) Summary of Spill Prevention Plan or O&M Manual modifications to be made, if necessary, to minimize the chances of future unauthorized discharges; and
- 7) Quantity and duration of the unauthorized discharge, and the amount recovered.

d. Communication Protocol

To clarify the multiple levels of notification, certification, and reporting, the current communication requirements for unauthorized discharges from municipal wastewater treatment plants are summarized in Table B that follows.

**Table B**  
 Summary of Communication Requirements for Unauthorized Discharges<sup>1</sup> from  
 Municipal Wastewater Treatment Plants

<b>Discharger is required to:</b>	<b>Agency Receiving Information</b>	<b>Time frame</b>	<b>Method for Contact</b>
1. Notify	California Emergency Management Agency (Cal EMA)	As soon as possible, but not later than <b>2 hours</b> after becoming aware of the unauthorized discharge.	Telephone – (800) 852-7550 (obtain a control number from Cal EMA)
	Local health department	As soon as possible, but not later than <b>2 hours</b> after becoming aware of the unauthorized discharge.	Depends on local health department
	Regional Water Board	As soon as possible, but not later than <b>2 hours</b> after becoming aware of the unauthorized discharge.	Electronic <sup>2</sup> <a href="http://www.wbers.net">www.wbers.net</a>
2. Certify	Regional Water Board	As soon as possible, but not later than <b>24 hours</b> after becoming aware of the unauthorized discharge.	Electronic <sup>3</sup> <a href="http://www.wbers.net">www.wbers.net</a>
3. Report	Regional Water Board	Within <b>5 business days</b> of becoming aware of the unauthorized discharge.	Electronic <sup>4</sup> <a href="http://www.wbers.net">www.wbers.net</a>

<sup>1</sup> California Code of Regulations, Title 23, Section 2250(b), defines an unauthorized discharge to be a discharge, not regulated by waste discharge requirements, of treated, partially treated, or untreated wastewater resulting from the intentional or unintentional diversion of wastewater from a collection, treatment or disposal system.

<sup>2</sup> In the event that the Discharger is unable to provide online notification within 2 hours of becoming aware of an unauthorized discharge, it shall phone the Regional Water Board’s spill hotline at (510) 622-2369 and convey the same information contained in the notification form. In addition, within 3 business days of becoming aware of the unauthorized discharge, the Discharger shall enter the notification information into the Regional Water Board’s online system in electronic format.

<sup>3</sup> In most instances, the 2-hour notification will also satisfy 24-hour certification requirements. This is because the notification form includes fields for documenting that OES and the local health department have been contacted. In other words, if the Discharger is able to complete all the fields in the notification form within 2 hours, certification requirements are also satisfied. In the event that the Discharger is unable to provide online certification within 24 hours of becoming aware of an unauthorized discharge, it shall phone the Regional Water Board’s spill hotline at (510) 622-2369 and convey the same information contained in the certification form. In addition, within 3 business days of becoming aware of the unauthorized discharge, the Discharger shall enter the certification information into the Regional Water Board’s online system in electronic format.

<sup>4</sup> If the Discharger cannot satisfy the 5-day reporting requirements via the Regional Water Board’s online reporting system, it shall submit a written report (preferably electronically in pdf) to the appropriate Regional Water Board case manager. In cases where the Discharger cannot satisfy the 5-day reporting requirements via the online reporting system, it must still complete the Regional Water Board’s online reporting requirements within 15 calendar days of becoming aware of the unauthorized discharge.

**F. Planned Changes** – Not supplemented

**G. Anticipated Noncompliance** – Not supplemented

**H. Other Noncompliance** – Not supplemented

**I. Other Information** – Not supplemented

**VI. STANDARD PROVISION – ENFORCEMENT** – Not Supplemented

**VII. ADDITIONAL PROVISIONS – NOTIFICATION LEVELS** – Not Supplemented

**VIII. DEFINITIONS** – This section is an addition to Standard Provisions (Attachment D)

More definitions can be found in Attachment A of this NPDES Permit.

1. Arithmetic Calculations

- a. Geometric mean is the antilog of the log mean or the back-transformed mean of the logarithmically transformed variables, which is equivalent to the multiplication of the antilogarithms. The geometric mean can be calculated with either of the following equations:

$$\text{Geometric Mean} = \text{Antilog} \left( \frac{1}{N} \sum_{i=1}^N \text{Log}(C_i) \right)$$

or

$$\text{Geometric Mean} = (C_1 * C_2 * \dots * C_N)^{1/N}$$

Where “N” is the number of data points for the period analyzed and “C” is the concentration for each of the “N” data points.

- b. Mass emission rate is obtained from the following calculation for any calendar day:

$$\text{Mass emission rate (lb/day)} = \frac{8.345}{N} \sum_{i=1}^N Q_i C_i$$

$$\text{Mass emission rate (kg/day)} = \frac{3.785}{N} \sum_{i=1}^N Q_i C_i$$

In which “N” is the number of samples analyzed in any calendar day and “Q<sub>i</sub>” and “C<sub>i</sub>” are the flow rate (MGD) and the constituent concentration (mg/L) associated with each of the “N” grab samples that may be taken in any calendar day. If a composite sample is taken, “C<sub>i</sub>” is the concentration measured in the composite sample and “Q<sub>i</sub>” is the average flow rate occurring during the period over which the samples are composited. The daily concentration of a constituent measured over any calendar day shall be determined from the flow-weighted average of the same constituent in the combined waste streams as follows:

$$C_d = \text{Average daily concentration} = \frac{1}{Q_t} \sum_{i=1}^N Q_i C_i$$

In which “N” is the number of component waste streams and “Q” and “C” are the flow rate (MGD) and the constituent concentration (mg/L) associated with each of the “N” waste streams. “Q<sub>t</sub>” is the total flow rate of the combined waste streams.

- c. Maximum allowable mass emission rate, whether for a 24-hour, weekly 7-day, monthly 30-day, or 6-month period, is a limitation expressed as a daily rate determined with the formulas in the paragraph above, using the effluent concentration limit specified in the permit for the period and the specified allowable flow.
- d. POTW removal efficiency is the ratio of pollutants removed by the treatment facilities to pollutants entering the treatment facilities (expressed as a percentage). The Discharger shall determine removal efficiencies using monthly averages (by calendar month unless otherwise specified) of pollutant concentration of influent and effluent samples collected at about the same time and using the following equation (or its equivalent):

$$\text{Removal Efficiency (\%)} = 100 \times [1 - (\text{Effluent Concentration} / \text{Influent Concentration})]$$

2. Biosolids means the solids, semi-liquid suspensions of solids, residues, screenings, grit, scum, and precipitates separated from or created in wastewater by the unit processes of a treatment system. It also includes, but is not limited to, all supernatant, filtrate, centrate, decantate, and thickener overflow and underflow in the solids handling parts of the wastewater treatment system.
3. Blending is the practice of recombining wastewater that has been biologically treated with wastewater that has bypassed around biological treatment units.
4. Bottom sediment sample is (1) a separate grab sample taken at each sampling station for the determination of selected physical-chemical parameters, or (2) four grab samples collected from different locations in the immediate vicinity of a sampling station while the boat is anchored and analyzed separately for macroinvertebrates.
5. Composite sample is a sample composed of individual grab samples collected manually or by an automatic sampling device on the basis of time or flow as specified in the MRP. For flow-based composites, the proportion of each grab sample included in the composite sample shall be within plus or minus five percent (+/-5%) of the representative flow rate of the waste stream being measured at the time of grab sample collection. Alternatively, equal volume grab samples may be individually analyzed with the flow-weighted average calculated by averaging flow-weighted ratios of each grab sample analytical result. Grab samples comprising time-based composite samples shall be collected at intervals not greater than those specified in the MRP. The quantity of each grab sample comprising a time-based composite sample shall be a set of flow proportional volumes as specified in the MRP. If a particular time-based or flow-based composite sampling protocol is not specified in the MRP, the Discharger shall determine and implement the most representative sampling protocol for the given parameter subject to Executive Officer approval.
6. Depth-integrated sample is defined as a water or waste sample collected by allowing a sampling device to fill during a vertical traverse in the waste or receiving water body being sampled. The Discharger shall collect depth-integrated samples in such a manner that the collected sample will be representative of the waste or water body at that sampling point.

7. Flow sample is an accurate measurement of the average daily flow volume using a properly calibrated and maintained flow measuring device.
8. Grab sample is an individual sample collected in a short period of time not exceeding 15 minutes. Grab samples represent only the condition that exists at the time the wastewater is collected.
9. Initial dilution is the process that results in the rapid and irreversible turbulent mixing of wastewater with receiving water around the point of discharge.
10. Overflow is the intentional or unintentional spilling or forcing out of untreated or partially treated wastes from a transport system (e.g., through manholes, at pump stations, and at collection points) upstream from the treatment plant headworks or from any part of a treatment plant facility.
11. Priority pollutants are those constituents referred to in 40 C.F.R. Part 122 as promulgated in the Federal Register, Vol. 65, No. 97, Thursday, May 18, 2000, also known as the California Toxics Rule, the presence or discharge of which could reasonably be expected to interfere with maintaining designated uses.
12. Storm water means storm water runoff, snow melt runoff, and surface runoff and drainage. It excludes infiltration and runoff from agricultural land.
13. Toxic pollutant means any pollutant listed as toxic under federal Clean Water Act section 307(a)(1) or under 40 C.F.R. 401.15.
14. Untreated waste is raw wastewater.
15. Waste, waste discharge, discharge of waste, and discharge are used interchangeably in the permit. The requirements of the permit apply to the entire volume of water, and the material therein, that is disposed of to surface and ground waters of the State of California.

**Table C**  
List of Monitoring Parameters and Analytical Methods

CTR No.	Pollutant/Parameter	Analytical Method <sup>6</sup>	Minimum Levels <sup>7</sup> (µg/l)											
			GC	GCMS	LC	Color	FAA	GFAA	ICP	ICP MS	SPGFAA	HYD RIDE	CVAA	DCP
1.	Antimony	204.2					10	5	50	0.5	5	0.5		1000
2.	Arsenic	206.3				20		2	10	2	2	1		1000
3.	Beryllium						20	0.5	2	0.5	1			1000
4.	Cadmium	200 or 213					10	0.5	10	0.25	0.5			1000
5a.	Chromium (III)	SM 3500												
5b.	Chromium (VI)	SM 3500				10	5							1000
	Chromium (total) <sup>8</sup>	SM 3500					50	2	10	0.5	1			1000
6.	Copper	200.9					25	5	10	0.5	2			1000
7.	Lead	200.9					20	5	5	0.5	2			10,000
8.	Mercury	1631 (note) <sup>9</sup>												
9.	Nickel	249.2					50	5	20	1	5			1000
10.	Selenium	200.8 or SM 3114B or C						5	10	2	5	1		1000
11.	Silver	272.2					10	1	10	0.25	2			1000
12.	Thallium	279.2					10	2	10	1	5			1000
13.	Zinc	200 or 289					20		20	1	10			
14.	Cyanide	SM 4500 CN <sup>-</sup> C or I				5								
15.	Asbestos (only required for dischargers to MUN waters) <sup>10</sup>	0100.2 <sup>11</sup>												
16.	2,3,7,8-TCDD and 17 congeners (Dioxin)	1613												
17.	Acrolein	603	2.0	5										
18.	Acrylonitrile	603	2.0	2										
19.	Benzene	602	0.5	2										
33.	Ethylbenzene	602	0.5	2										
39.	Toluene	602	0.5	2										
20.	Bromoform	601	0.5	2										
21.	Carbon Tetrachloride	601	0.5	2										
22.	Chlorobenzene	601	0.5	2										
23.	Chlorodibromomethane	601	0.5	2										

<sup>6</sup> The suggested method is the U.S. EPA Method unless otherwise specified (SM = Standard Methods). The Discharger may use another U.S. EPA-approved or recognized method if that method has a level of quantification below the applicable water quality objective. Where no method is suggested, the Discharger has the discretion to use any standard method.

<sup>7</sup> Minimum levels are from the *State Implementation Policy*. They are the concentration of the lowest calibration standard for that technique based on a survey of contract laboratories. Laboratory techniques are defined as follows: GC = Gas Chromatography; GCMS = Gas Chromatography/Mass Spectrometry; LC = High Pressure Liquid Chromatography; Color = Colorimetric; FAA = Flame Atomic Absorption; GFAA = Graphite Furnace Atomic Absorption; ICP = Inductively Coupled Plasma; ICPMS = Inductively Coupled Plasma/Mass Spectrometry; SPGFAA = Stabilized Platform Graphite Furnace Atomic Absorption (i.e., U.S. EPA 200.9); Hydride = Gaseous Hydride Atomic Absorption; CVAA = Cold Vapor Atomic Absorption; DCP = Direct Current Plasma.

<sup>8</sup> Analysis for total chromium may be substituted for analysis of chromium (III) and chromium (VI) if the concentration measured is below the lowest hexavalent chromium criterion (11 µg/l).

<sup>9</sup> The Discharger shall use ultra-clean sampling (U.S. EPA Method 1669) and ultra-clean analytical methods (U.S. EPA Method 1631) for mercury monitoring. The minimum level for mercury is 2 ng/l (or 0.002 µg/l).

<sup>10</sup> MUN = Municipal and Domestic Supply. This designation, if applicable, is in the Findings of the permit.

<sup>11</sup> Determination of Asbestos Structures over 10 [micrometers] in Length in Drinking Water Using MCE Filters, U.S. EPA 600/R-94-134, June 1994.

CTR No.	Pollutant/Parameter	Analytical Method <sup>6</sup>	Minimum Levels <sup>7</sup> (µg/l)											
			GC	GCMS	LC	Color	FAA	GFAA	ICP	ICP MS	SPGFAA	HYD RIDE	CVAA	DCP
24.	Chloroethane	601	0.5	2										
25.	2-Chloroethylvinyl Ether	601	1	1										
26.	Chloroform	601	0.5	2										
75.	1,2-Dichlorobenzene	601	0.5	2										
76.	1,3-Dichlorobenzene	601	0.5	2										
77.	1,4-Dichlorobenzene	601	0.5	2										
27.	Dichlorobromomethane	601	0.5	2										
28.	1,1-Dichloroethane	601	0.5	1										
29.	1,2-Dichloroethane	601	0.5	2										
30.	1,1-Dichloroethylene or 1,1-Dichloroethene	601	0.5	2										
31.	1,2-Dichloropropane	601	0.5	1										
32.	1,3-Dichloropropylene or 1,3-Dichloropropene	601	0.5	2										
34.	Methyl Bromide or Bromomethane	601	1.0	2										
35.	Methyl Chloride or Chloromethane	601	0.5	2										
36.	Methylene Chloride or Dichloromethane	601	0.5	2										
37.	1,1,2,2-Tetrachloroethane	601	0.5	1										
38.	Tetrachloroethylene	601	0.5	2										
40.	1,2-Trans-Dichloroethylene	601	0.5	1										
41.	1,1,1-Trichloroethane	601	0.5	2										
42.	1,1,2-Trichloroethane	601	0.5	2										
43.	Trichloroethene	601	0.5	2										
44.	Vinyl Chloride	601	0.5	2										
45.	2-Chlorophenol	604	2	5										
46.	2,4-Dichlorophenol	604	1	5										
47.	2,4-Dimethylphenol	604	1	2										
48.	2-Methyl-4,6-Dinitrophenol or Dinitro-2-methylphenol	604	10	5										
49.	2,4-Dinitrophenol	604	5	5										
50.	2-Nitrophenol	604		10										
51.	4-Nitrophenol	604	5	10										
52.	3-Methyl-4-Chlorophenol	604	5	1										
53.	Pentachlorophenol	604	1	5										
54.	Phenol	604	1	1		50								
55.	2,4,6-Trichlorophenol	604	10	10										
56.	Acenaphthene	610 HPLC	1	1	0.5									
57.	Acenaphthylene	610 HPLC		10	0.2									
58.	Anthracene	610 HPLC		10	2									
60.	Benzo(a)Anthracene or 1,2 Benzanthracene	610 HPLC	10	5										
61.	Benzo(a)Pyrene	610 HPLC		10	2									
62.	Benzo(b)Fluoranthene or 3,4 Benzo(b)fluoranthene	610 HPLC		10	10									
63.	Benzo(ghi)Perylene	610 HPLC		5	0.1									
64.	Benzo(k)Fluoranthene	610 HPLC		10	2									
74.	Dibenzo(a,h)Anthracene	610 HPLC		10	0.1									
86.	Fluoranthene	610 HPLC	10	1	0.05									
87.	Fluorene	610 HPLC		10	0.1									
92.	Indeno(1,2,3-cd) Pyrene	610 HPLC		10	0.05									
100.	Pyrene	610 HPLC		10	0.05									



CTR No.	Pollutant/Parameter	Analytical Method <sup>6</sup>	Minimum Levels <sup>7</sup> (µg/l)												
			GC	GCMS	LC	Color	FAA	GFAA	ICP	ICP MS	SPGFAA	HYD RIDE	CVAA	DCP	
68.	Bis(2-Ethylhexyl)Phthalate	606 or 625	10	5											
70.	Butylbenzyl Phthalate	606 or 625	10	10											
79.	Diethyl Phthalate	606 or 625	10	2											
80.	Dimethyl Phthalate	606 or 625	10	2											
81.	Di-n-Butyl Phthalate	606 or 625		10											
84.	Di-n-Octyl Phthalate	606 or 625		10											
59.	Benzidine	625		5											
65.	Bis(2-Chloroethoxy)Methane	625		5											
66.	Bis(2-Chloroethyl)Ether	625	10	1											
67.	Bis(2-Chloroisopropyl)Ether	625	10	2											
69.	4-Bromophenyl Phenyl Ether	625	10	5											
71.	2-Chloronaphthalene	625		10											
72.	4-Chlorophenyl Phenyl Ether	625		5											
73.	Chrysene	625		10	5										
78.	3,3'-Dichlorobenzidine	625		5											
82.	2,4-Dinitrotoluene	625	10	5											
83.	2,6-Dinitrotoluene	625		5											
85.	1,2-Diphenylhydrazine (note) <sup>12</sup>	625		1											
88.	Hexachlorobenzene	625	5	1											
89.	Hexachlorobutadiene	625	5	1											
90.	Hexachlorocyclopentadiene	625	5	5											
91.	Hexachloroethane	625	5	1											
93.	Isophorone	625	10	1											
94.	Naphthalene	625	10	1	0.2										
95.	Nitrobenzene	625	10	1											
96.	N-Nitrosodimethylamine	625	10	5											
97.	N-Nitrosodi-n-Propylamine	625	10	5											
98.	N-Nitrosodiphenylamine	625	10	1											
99.	Phenanthrene	625		5	0.05										
101.	1,2,4-Trichlorobenzene	625	1	5											
102.	Aldrin	608	0.005												
103.	α-BHC	608	0.01												
104.	β-BHC	608	0.005												
105.	γ-BHC (Lindane)	608	0.02												
106.	δ-BHC	608	0.005												
107.	Chlordane	608	0.1												
108.	4,4'-DDT	608	0.01												
109.	4,4'-DDE	608	0.05												
110.	4,4'-DDD	608	0.05												
111.	Dieldrin	608	0.01												
112.	Endosulfan (alpha)	608	0.02												
113.	Endosulfan (beta)	608	0.01												
114.	Endosulfan Sulfate	608	0.05												
115.	Endrin	608	0.01												
116.	Endrin Aldehyde	608	0.01												
117.	Heptachlor	608	0.01												

<sup>12</sup> Measurement for 1,2-Diphenylhydrazine may use azobenzene as a screen: if azobenzene is measured at >1 ug/l, then the Discharger shall analyze for 1,2-Diphenylhydrazine.

CTR No.	Pollutant/Parameter	Analytical Method <sup>6</sup>	Minimum Levels <sup>7</sup> (µg/l)											
			GC	GCMS	LC	Color	FAA	GFAA	ICP	ICP MS	SPGFAA	HYD RIDE	CVAA	DCP
118.	Heptachlor Epoxide	608	0.01											
119-125	PCBs: Aroclors 1016, 1221, 1232, 1242, 1248, 1254, 1260	608	0.5											
126.	Toxaphene	608	0.5											