

**CALIFORNIA REGIONAL WATER QUALITY CONTROL BOARD**

**SAN DIEGO REGION**

9174 Sky Park Court, Suite 100, San Diego, CA 92123-4340  
 Phone (858) 467-2952 • Fax (858) 571-6972  
<http://www.waterboards.ca.gov/sandiego/>

**SUPPORTING  
DOCUMENT 3**

**TENTATIVE ORDER NO. R9-2008-0096  
 NPDES NO. CA0109347**

**WASTE DISCHARGE REQUIREMENTS  
 FOR THE MARINE CORPS BASE, CAMP PENDLETON  
 SOUTHERN REGION TERTIARY TREATMENT PLANT  
 DISCHARGE TO THE PACIFIC OCEAN THROUGH THE  
 OCEANSIDE OCEAN OUTFALL, SAN DIEGO COUNTY**

The following Discharger is subject to waste discharge requirements as set forth in this Order:

**Table 1. Discharger Information**

<b>Discharger</b>	<b>Marine Corps Base, Camp Pendleton</b>
<b>Name of Facility</b>	<b>Southern Region Tertiary Treatment Plant (SRTTP)</b>
<b>Facility Address</b>	<b>Marine Corps Base</b>
	<b>Camp Pendleton, CA 92055</b>
	<b>San Diego County</b>
The U.S. Environmental Protection Agency (USEPA) and the Regional Water Quality Control Board have classified this discharge as a major discharge.	

The discharge by the Marine Corps Base, Camp Pendleton from the discharge points identified below is subject to waste discharge requirements as set forth in this Order:

**Table 2. Discharge Location**

<b>Discharge Point</b>	<b>Effluent Description</b>	<b>Discharge Point Latitude</b>	<b>Discharge Point Longitude</b>	<b>Receiving Water</b>
001	<b>Secondary- and Tertiary-treated Effluent</b>	33° 09' 46" N	117° 23' 28" W	Pacific Ocean

**Table 3. Administrative Information**

This Order was adopted by the Regional Water Quality Control Board on:	<b>September 10, 2008</b>
This Order shall become effective on:	<b>November 1, 2008</b>
This Order shall expire on:	<b>November 1, 2013</b>
The Discharger shall file a Report of Waste Discharge in accordance with title 23, California Code of Regulations, as application for issuance of new waste discharge requirements no later than:	<b>180 days prior to the Order expiration date</b>

I, John Robertus, Executive Officer, do hereby certify that this Order with all attachments is a full, true, and correct copy of an Order adopted by the California Regional Water Quality Control Board, San Diego Region, on September 10, 2008.

TENTATIVE  
 John Robertus, Executive Officer

## Table of Contents

I.	Facility Information .....	4
II.	Findings .....	5
III.	Discharge Prohibitions.....	11
IV.	Effluent Limitations and Discharge Specifications .....	12
	A. Effluent Limitations and Performance Goals – Discharge Point No. 001 .....	12
	B. Land Discharge Specifications – Not Applicable.....	18
	C. Reclamation Specifications – Not Applicable.....	18
V.	Receiving Water Limitations .....	19
	A. Surface Water Limitation.....	19
	B. Groundwater Limitations – Not Applicable .....	21
VI.	Provisions .....	22
	A. Standard Provisions.....	22
	B. Monitoring and Reporting Program (MRP) Requirements .....	24
	C. Special Provisions.....	24
	1. Reopener Provisions.....	24
	2. Special Studies, Technical Reports and Additional Monitoring Requirements.....	25
	3. Best Management Practices and Pollution Prevention – Not Applicable .....	26
	4. Construction, Operation and Maintenance Specifications – Not Applicable.....	26
	5. Special Provisions for Municipal Facilities (POTWs Only) .....	26
	6. Other Special Provisions – Not Applicable.....	30
	7. Compliance Schedules – Not Applicable .....	30
VII.	Compliance Determination .....	31
	A. Compliance with Average Monthly Effluent Limitation (AMEL) .....	31
	B. Compliance with Average Weekly Effluent Limitation (AWEL).....	31
	C. Compliance with Maximum Daily Effluent Limitation (MDEL) .....	31
	D. Compliance with Instantaneous Minimum Effluent Limitation .....	31
	E. Compliance with Instantaneous Maximum Effluent Limitation .....	32
	F. Compliance with Six-month Median Effluent Limitation .....	32
	G. Mass and Concentration Limitations .....	32
	H. Percent Removal .....	32
	I. 2005 California Ocean Plan Provisions for Table B Constituents .....	33
	1. Sampling Reporting Protocols .....	33
	2. Compliance Determination.....	33

## List of Tables

Table 1.	Discharger Information .....	1
Table 2.	Discharge Location .....	1
Table 3.	Administrative Information .....	1
Table 4.	Facility Information.....	4
Table 5.	Basin Plan Beneficial Uses .....	7
Table 6.	Ocean Plan Beneficial Uses .....	8
Table 7.	Effluent Limitations Based on Secondary Treatment Requirements and Table A of the Ocean Plan.....	12
Table 8.	Effluent Limitations Based on the Ocean Plan .....	12
Table 9.	Performance Goals Based on the Ocean Plan.....	13

**List of Attachments**

Attachment A – Definitions.....A-1  
Attachment B – Map .....B-1  
Attachment C – Flow Schematic .....C-1  
Attachment D – Standard Provisions .....D-1  
Attachment E – Monitoring and Reporting Program .....E-1  
Attachment F – Fact Sheet .....F-1  
Attachment G – Basin Plan and Ocean Plan Requirements.....A-1  
Attachment H – Sanitary Sewer Overflow Requirements .....A-1

**I. FACILITY INFORMATION**

The following Discharger is subject to waste discharge requirements as set forth in this Order:

**Table 4. Facility Information**

<b>Discharger</b>	<b>Marine Corps Base, Camp Pendleton</b>
<b>Name of Facility</b>	<b>Southern Region Tertiary Treatment Plant (SRTTP)</b>
<b>Facility Address</b>	<b>Marine Corps Base</b>
	<b>Camp Pendleton, CA 92055</b>
	<b>San Diego County</b>
<b>Facility Contact, Title, and Phone</b>	<b>Khalique Khan, Environmental Engineering Division Head, Assistant Chief of Staff, Environmental Security, (760) 725-0141</b>
<b>Mailing Address</b>	<b>Box 555008, Camp Pendleton, CA 92055</b>
<b>Type of Facility</b>	<b>Wastewater Treatment Facility for Military Base (Federal Facility)</b>
<b>Facility Design Flow</b>	<b>3.6 million gallons per day (MGD) (Permitted); 5.0 MGD (Design)</b>

## II. FINDINGS

The California Regional Water Quality Control Board, San Diego Region (hereinafter Regional Water Board), finds:

- A. **Background.** The Marine Corps Base, Camp Pendleton (hereinafter Discharger) is currently discharging pursuant to Order No. R9-2003-0155 and National Pollutant Discharge Elimination System (NPDES) Permit No. CA0109347. The Discharger submitted a Report of Waste Discharge (ROWD), dated February 14, 2007, and applied for a NPDES permit renewal to discharge up to 3.6 MGD of secondary- and tertiary-treated wastewater from the Southern Region Tertiary Treatment Plant (SRTTP), hereinafter Facility. Supplemental information was requested on March 19, 2008 and received on April 3, 2008.

For the purposes of this Order, references to the “discharger” or “permittee” in applicable federal and State laws, regulations, plans, or policy are held to be equivalent to references to the Discharger herein.

- B. **Facility Description.** SRTTP’s treatment train consists of a mechanical bar screen (and one manual backup), two grit vortexes, alum injection, five sequencing batch reactors (SBRs), two equalization basins for the SBRs, three disk filters, and two chlorine contact basins. Chlorination will only be performed on effluent that is distributed as reclaimed water.

A biofilter has been installed for odor control. Foul air from the influent pump station, the screening channels, the grit collector and the sludge processing room is routed to the biofilter to receive natural biological removal of the odors through a bed of wood chip and compost filter media.

Submersible pumps in the SBRs pump waste activated sludge to two aerobic digesters. Each digester is equipped with a surface aerator and a decanting mechanism to thicken the sludge. Digested sludge is pumped to two dewatering belt filter presses. A gravity belt thickener is available as a back-up for the decanters on the digesters. Dewatered solids are conveyed by a belt conveyor to a trailer and hauled to sludge drying beds for additional drying if necessary. Biosolids are hauled to an approved landfill off-base.

The SRTTP has a certified daily average flow capacity of 5 MGD (with daily peaks of 10 MGD). However, capacity limitations for discharges through the Oceanside Ocean Outfall (OOO) currently limit the discharge of wastewater from Camp Pendleton to the Pacific Ocean through the OOO to 3.6 MGD.

- C. **Legal Authorities.** This Order is issued pursuant to section 402 of the federal Clean Water Act (CWA) and implementing regulations adopted by the U.S. Environmental Protection Agency (USEPA) and chapter 5.5, division 7 of the California Water Code (commencing with section 13370). It shall serve as a NPDES permit for point source discharges from this facility to surface waters. This Order also serves as Waste

Discharge Requirements (WDRs) pursuant to article 4, chapter 4, division 7 of the Water Code (commencing with section 13260).

- D. **Background and Rationale for Requirements.** The Regional Water Board developed the requirements in this Order based on information submitted as part of the application, through monitoring and reporting programs, and other available information. The Fact Sheet (Attachment F), which contains background information and rationale for Order requirements, is hereby incorporated into this Order and constitutes part of the Findings for this Order. Attachments A through E and H are also incorporated into this Order.
- E. **California Environmental Quality Act (CEQA).** Under Water Code section 13389, this action to adopt an NPDES permit is exempt from the provisions of CEQA, Public Resources Code sections 21100-21177.
- F. **Technology-based Effluent Limitations.** Section 301(b) of the CWA and implementing USEPA permit regulations at Title 40 of the Code of Federal Regulations (CFR)<sup>1</sup>, Part 122.44 (40 CFR 122.44) require that permits include conditions meeting applicable technology-based requirements at a minimum, and any more stringent effluent limitations necessary to meet applicable water quality standards. The discharge authorized by this Order must meet minimum federal technology-based requirements based on Secondary Treatment Standards at 40 CFR 133. A detailed discussion of the technology-based effluent limitations development is included in the Fact Sheet (Attachment F).
- G. **Water Quality-based Effluent Limitations.** Section 301(b) of the CWA and section 122.44(d) require that permits include limitations more stringent than applicable federal technology-based requirements where necessary to achieve applicable water quality standards.

Section 122.44(d)(1)(i) mandates that permits include effluent limitations for all pollutants that are or may be discharged at levels that have the reasonable potential to cause or contribute to an exceedance of a water quality standard, including numeric and narrative objectives within a standard. Where reasonable potential has been established for a pollutant, but there is no numeric criterion or objective for the pollutant, water quality-based effluent limitations (WQBELs) must be established using: (1) USEPA criteria guidance under CWA section 304(a), supplemented where necessary by other relevant information; (2) an indicator parameter for the pollutant of concern; or (3) a calculated numeric water quality criterion, such as a proposed State criterion or policy interpreting the State's narrative criterion, supplemented with other relevant information, as provided in section 122.44(d)(1)(vi).

- H. **Water Quality Control Plans.** The Regional Water Board adopted a Water Quality Control Plan for the San Diego Region (hereinafter Basin Plan) on September 8, 1994 that designates beneficial uses, establishes water quality objectives, and contains implementation programs and policies to achieve those objectives for the Pacific Ocean and other receiving waters addressed through the plan. Subsequent revisions to the

---

<sup>1</sup> All further statutory references are to title 40 of the Code of Federal Regulations unless otherwise indicated.

Basin Plan have also been adopted by the Regional Water Board and approved by the State Water Board. Beneficial uses applicable to the Pacific Ocean specified in the Basin Plan are as follows:

**Table 5. Basin Plan Beneficial Uses**

Discharge Point	Receiving Water Name	Beneficial Use(s)
001	Pacific Ocean	Industrial Service Supply; navigation; contact water recreation; non-contact water recreation; commercial and sport fishing; preservation of biological habitats of special significance; wildlife habitat; rare, threatened, or endangered species, marine habitat, aquaculture, migration of aquatic organisms; spawning, reproduction, and/or early development; shellfish harvesting

The Basin Plan relies primarily on the requirements of the Water Quality Control Plan for Ocean Waters of California (Ocean Plan) for protection of the beneficial uses of the State ocean waters. The Basin Plan, however, may contain additional water quality objectives applicable to the Discharger.

Under section 303(d) of the 1972 Clean Water Act, states, territories and authorized tribes are required to develop lists of water quality limited segments. The waters on these lists do not meet water quality standards, even after point sources of pollution have installed the minimum required levels of pollution control technology. On November 30, 2006 USEPA gave final approval to California’s 2006 section 303(d) List of Water Quality Limited Segments. The 303 (d) list includes the following sections of Pacific Ocean shoreline within the proximity of the OOO as impaired for bacteria indicators: 0.5 miles of Pacific Ocean shoreline at the mouth of the San Luis Rey River; 1.1 miles of Pacific Ocean shoreline at the mouth of Loma Alta Creek; and 1.2 miles of Pacific Ocean shoreline at Buena Vista Creek. Impairment has been detected at the shorelines indicated above; however, the receiving waters in the immediate vicinity of the discharge point are not included on the current 303 (d) list.

The State Water Board adopted the *Water Quality Control Plan for Control of Temperature in the Coastal and Interstate Water and Enclosed Bays and Estuaries of California* (Thermal Plan) on May 18, 1972, and amended this plan on September 18, 1975. This plan contains temperature objectives for surface waters.

Requirements of this Order implement the Basin Plan.

- I. **California Ocean Plan.** The State Water Board adopted the *Water Quality Control Plan for Ocean Waters of California, California Ocean Plan* (Ocean Plan) in 1972 and amended it in 1978, 1983, 1988, 1990, 1997, 2000, and 2005. The State Water Board adopted the latest amendment on April 21, 2005 and it became effective on February 14, 2006. The Ocean Plan is applicable, in its entirety, to point source discharges to the ocean. The Ocean Plan identifies beneficial uses of ocean waters of the State to be protected as summarized below:

**Table 6. Ocean Plan Beneficial Uses**

Discharge Point	Receiving Water	Beneficial Uses
001	Pacific Ocean	Industrial water supply; water contact and non-contact recreation, including aesthetic enjoyment; navigation; commercial and sport fishing; mariculture; preservation and enhancement of designated Areas of Special Biological Significance (ASBS); rare and endangered species; marine habitat; fish spawning and shellfish harvesting

In order to protect the beneficial uses, the Ocean Plan establishes water quality objectives and a program of implementation. Requirements of this Order implement the Ocean Plan.

- J. **Alaska Rule.** On March 30, 2000, USEPA revised its regulation that specifies when new and revised State and tribal water quality standards (WQS) become effective for CWA purposes. (40 CFR § 131.21; 65 Fed. Reg. 24641 (April 27, 2000)) Under the revised regulation (also known as the Alaska rule), new and revised standards submitted to USEPA after May 30, 2000, must be approved by USEPA before being used for CWA purposes. The final rule also provides that standards already in effect and submitted to USEPA by May 30, 2000 may be used for CWA purposes, whether or not approved by USEPA.
- K. **Stringency of Requirements for Individual Pollutants.** This Order contains both technology-based and water quality-based effluent limitations for individual pollutants. The technology-based effluent limitations consist of restrictions on biochemical oxygen demand 5-day @ 20 °C (BOD<sub>5</sub>), total suspended solids (TSS), oil and grease, settleable solids, turbidity, and pH. Restrictions on BOD<sub>5</sub>, TSS, oil and grease, settleable solids, turbidity, and pH are discussed in section IV.B.2 of the Fact Sheet. This Order’s technology-based pollutant restrictions implement the minimum, applicable federal technology-based requirements. These limitations are not more stringent than required by the CWA.

Water quality-based effluent limitations have been scientifically derived to implement water quality objectives that protect beneficial uses. Both the beneficial uses and the water quality objectives have been approved pursuant to federal law and are the applicable federal water quality standards. The scientific procedures for calculating the individual water quality-based effluent limitations are based on the Ocean Plan, which was approved by USEPA on February 14, 2006. All beneficial uses and water quality objectives contained in the Basin Plan were approved under State law and submitted to and approved by USEPA prior to May 30, 2000. Any water quality objectives and beneficial uses submitted to USEPA prior to May 30, 2000, but not approved by USEPA before that date, are nonetheless “applicable water quality standards for purposes of the CWA” pursuant to section 131.21(c)(1). Collectively, this Order’s restrictions on individual pollutants are no more stringent than required to implement the requirements of the CWA.

- L. **Antidegradation Policy.** Section 131.12 requires that the State water quality standards include an antidegradation policy consistent with the federal policy. The



State Water Board established California's antidegradation policy in State Water Board Resolution No. 68-16. Resolution No. 68-16 incorporates the federal antidegradation policy where the federal policy applies under federal law. Resolution No. 68-16 requires that existing quality of waters be maintained unless degradation is justified based on specific findings. The Regional Water Board's Basin Plan implements, and incorporates by reference, both the State and federal antidegradation policies. As discussed in detail in the Fact Sheet the permitted discharge is consistent with the antidegradation provision of section 131.12 and State Water Board Resolution No. 68-16.

- M. Anti-Backsliding Requirements.** Sections 402(o)(2) and 303(d)(4) of the CWA and federal regulations at title 40, Code of Federal Regulations section 122.44(l) prohibit backsliding in NPDES permits. These anti-backsliding provisions require effluent limitations in a reissued permit to be as stringent as those in the previous permit, with some exceptions where limitations may be relaxed. Some effluent limitations in this Order are less stringent than those in the previous Order. As discussed in detail in the Fact Sheet this relaxation of effluent limitations is consistent with the anti-backsliding requirements of the CWA and federal regulations.
- N. Endangered Species Act.** This Order does not authorize any act that results in the taking of a threatened or endangered species or any act that is now prohibited, or becomes prohibited in the future, under either the California Endangered Species Act (Fish and Game Code sections 2050 to 2097) or the Federal Endangered Species Act (16 U.S.C.A. sections 1531 to 1544). This Order requires compliance with effluent limits, receiving water limits, and other requirements to protect the beneficial uses of waters of the State. The discharger is responsible for meeting all requirements of the applicable Endangered Species Act.
- O. Monitoring and Reporting.** Section 122.48 requires that all NPDES permits specify requirements for recording and reporting monitoring results. Water Code sections 13267 and 13383 authorizes the Regional Water Board to require technical and monitoring reports. The Monitoring and Reporting Program establishes monitoring and reporting requirements to implement federal and State requirements. This Monitoring and Reporting Program is provided in Attachment E.
- P. Standard and Special Provisions.** Standard Provisions, which apply to all NPDES permits in accordance with section 122.41, and additional conditions applicable to specified categories of permits in accordance with section 122.42, are provided in Attachment D. The Regional Water Board has also included in this Order special provisions applicable to the Discharger. A rationale for the special provisions contained in this Order is provided in the attached Fact Sheet.
- Q. Provisions and Requirements Implementing State Law.** The provisions/requirements in subsections VI.C. of this Order are included to implement State law only. These provisions/requirements are not required or authorized under the federal CWA; consequently, violations of these provisions/requirements are not subject to the enforcement remedies that are available for NPDES violations.

**R. Notification of Interested Parties.** The Regional Water Board has notified the Discharger and interested agencies and persons of its intent to prescribe Waste Discharge Requirements for the discharge and has provided them with an opportunity to submit their written comments and recommendations. Details of notification are provided in the Fact Sheet of this Order.

**S. Consideration of Public Comment.** The Regional Water Board, in a public meeting, heard and considered all comments pertaining to the discharge. Details of the Public Hearing are provided in the Fact Sheet of this Order.

THEREFORE, IT IS HEREBY ORDERED, that this Order supersedes Order No. R9-2003-0155 except for enforcement purposes, and, in order to meet the provisions contained in division 7 of the Water Code (commencing with section 13000) and regulations adopted thereunder, and the provisions of the federal Clean Water Act (CWA) and regulations and guidelines adopted thereunder, the Discharger shall comply with the requirements in this Order.

### III. DISCHARGE PROHIBITIONS

- A. The discharge of waste in a manner or to locations that have not been specifically authorized by this order and permit, or for which valid waste discharge requirements/NPDES permits are not in force, is prohibited.
- B. The Discharger shall comply with all requirements of the Basin Plan Waste Discharge Prohibitions which are hereby included in this Order by reference.
- C. Compliance with Discharge Prohibitions contained in Section III.H of the Ocean Plan is a requirement of this Order.
- D. The dumping or deposition, from shore or from vessels, of oil, garbage, trash or other solid municipal, industrial, or agricultural waste directly into waters subject to tidal action or adjacent to waters subject to tidal action in any manner which may permit it to be washed into waters subject to tidal action, is prohibited.
- E. The discharge of polychlorinated biphenyl compounds, such as those used for transformer fluid, is prohibited.
- F. The bypassing of untreated wastes containing concentrations of pollutants in excess of those in Tables A or B of the Ocean Plan is prohibited, except under upset conditions, as described in Attachment D of this Order, Standard Provision I. H.

#### IV. EFFLUENT LIMITATIONS AND DISCHARGE SPECIFICATIONS

##### A. Effluent Limitations and Performance Goals – Discharge Point No. 001

###### 1. Final Effluent Limitations – Discharge Point No. 001

The discharge of effluent to Discharge Point No. 001 shall be measured at Monitoring Location EFF-001 as described in Attachment E, Monitoring and Reporting Program, except as otherwise noted. The effluent limitations and performance goals below are enforceable to the number of significant digits given in the effluent limitation or performance goal.

- a. The Discharger shall maintain compliance with the following effluent limitations at Discharge Point No. 001, with compliance measured at Monitoring Location No. EFF-001 as described in the attached MRP:

**Table 7. Effluent Limitations Based on Secondary Treatment Requirements and Table A of the Ocean Plan**

Parameter	Unit	Effluent Limitations		
		Average Monthly	Average Weekly	Instantaneous Maximum
Flow Rate	MGD	3.6		
BOD <sub>5</sub> <sup>1</sup>	mg/L	30	45	
TSS <sup>1</sup>	mg/L	30	45	--
Oil and Grease	mg/L	25	40	75
Settleable Solids	ml/L	1.0	1.5	3.0
Turbidity	NTU	75	100	225
pH	Standard unit	--	--	<sup>2</sup>

<sup>1</sup> The average monthly percent removal of BOD 5-day 20°C and total suspended solids shall not be less than 85 percent.

<sup>2</sup> Within limit of 6.0 to 9.0 at all times.

- b. The discharge of effluent from the Discharger’s Facilities to Discharge Point No. 001, as monitored at Monitoring Location EFF-001, shall maintain compliance with the following effluent limitations:

**Table 8. Effluent Limitations Based on the Ocean Plan**

Parameter	Unit	Water Quality-based Effluent Limitations <sup>1</sup>			
		6-Month Median	Maximum Daily	Instantaneous Maximum	30-Day Average
<b>BASED ON OBJECTIVES FOR PROTECTION OF MARINE AQUATIC LIFE</b>					
Chronic Toxicity <sup>2</sup>	TUc	NA	145	NA	--
Copper, Total Recoverable	µg/L	9.00E+01	8.82E+02	2.47E+03	--
	lb/day	2.70E+00	2.65E+01	7.40E+01	--
Total Residual Chlorine	µg/L	1.76E+02	7.04E+02	5.28E+03	--
	lb/day	5.28E+00	2.11E+01	1.59E+02	--

<sup>1</sup> Scientific “E” notation is used to express certain values. In scientific “E” notation, the number following the “E” indicates that position of the decimal point in the value. Negative numbers after the

“E” indicate that the value is less than 1, and positive numbers after the “E” indicate that the value is greater than 1. In this notation a value of 6.1E-02 represents  $6.1 \times 10^{-2}$  or 0.061, 6.1E+02 represents  $6.1 \times 10^2$  or 610, and 6.1E+00 represents  $6.1 \times 10^0$  or 6.1.

<sup>2</sup> Chronic toxicity expressed as Chronic Toxicity Units (TUc) = 100/NOEL, where NOEL (No Observed Effect Level) is expressed as the maximum percent effluent or receiving water that causes no observable effect on a test organism.

- c. Constituents that do not have reasonable potential or had inconclusive reasonable potential analysis results are referred to as performance goal constituents and assigned the performance goals listed in the following table. Performance goal constituents shall also be monitored at EFF-001, but the results will be used for informational purposes only, not compliance determination.

**Table 9. Performance Goals Based on the Ocean Plan**

Parameter	Unit	Performance Goals <sup>1</sup>			
		6-Month Median	Maximum Daily	Instantaneous Maximum	30-Day Average
<b>BASED ON OBJECTIVES FOR PROTECTION OF MARINE AQUATIC LIFE</b>					
Arsenic, Total Recoverable	µg/L	4.43E+02	2.56E+03	6.78E+03	--
	lb/day	1.33E+01	7.67E+01	2.04E+02	--
Cadmium, Total Recoverable	µg/L	8.80E+01	3.52E+02	8.80E+02	--
	lb/day	2.64E+00	1.06E+01	2.64E+01	--
Chromium VI, Total Recoverable <sup>2</sup>	µg/L	1.76E+02	7.04E+02	1.76E+03	--
	lb/day	5.28E+00	2.11E+01	5.28E+01	--
Lead, Total Recoverable	µg/L	1.76E+02	7.04E+02	1.76E+03	--
	lb/day	5.28E+00	2.11E+01	5.28E+01	--
Mercury, Total Recoverable	µg/L	3.48E+00	1.40E+01	3.52E+01	--
	lb/day	1.04E-01	4.21E-01	1.06E+00	--
Nickel, Total Recoverable	µg/L	4.40E+02	1.76E+03	4.40E+03	--
	lb/day	1.32E+01	5.28E+01	1.32E+02	--
Selenium, Total Recoverable	µg/L	1.32E+03	5.28E+03	1.32E+04	--
	lb/day	3.96E+01	1.59E+02	3.96E+02	--
Silver, Total Recoverable	µg/L	4.77E+01	2.32E+02	6.02E+02	--
	lb/day	1.43E+00	6.98E+00	1.81E+01	--
Zinc, Total Recoverable	µg/L	1.06E+03	6.34E+03	1.69E+04	--
	lb/day	3.19E+01	1.90E+02	5.08E+02	--
Cyanide, Total Recoverable <sup>3</sup>	µg/L	8.80E+01	3.52E+02	8.80E+02	--
	lb/day	2.64E+00	1.06E+01	2.64E+01	--
Ammonia (expressed as nitrogen)	µg/L	5.28E+04	2.11E+05	5.28E+05	--
	lb/day	1.59E+03	6.34E+03	1.59E+04	--
Acute Toxicity	TUa	NA	2.64E+01	NA	--
Phenolic Compounds (non-chlorinated)	µg/L	2.64E+03	1.06E+04	2.64E+04	--
	lb/day	7.93E+01	3.17E+02	7.93E+02	--

Parameter	Unit	Performance Goals <sup>1</sup>			
		6-Month Median	Maximum Daily	Instantaneous Maximum	30-Day Average
Chlorinated Phenolics	µg/L	8.80E+01	3.52E+02	8.80E+02	--
	lb/day	2.64E+00	1.06E+01	2.64E+01	--
Endosulfan <sup>11</sup>	µg/L	7.92E-01	1.58E+00	2.38E+00	--
	lb/day	2.38E-02	4.76E-02	7.13E-02	--
Endrin	µg/L	1.76E-01	3.52E-01	5.28E-01	--
	lb/day	5.28E-03	1.06E-02	1.59E-02	--
HCH <sup>4</sup>	µg/L	3.52E-01	7.04E-01	1.06E+00	--
	lb/day	1.06E-02	2.11E-02	3.17E-02	--
Radioactivity	pci/l	Not to exceed limits specified in Title 17, Division 1, Chapter 5, Subchapter 4, Group 3, Article 3, Section 30253 of the California Code of Regulations, Reference to Section 30253 is prospective, including future changes to any incorporated provisions of federal law, as the changes take effect.			
<b>OBJECTIVES FOR PROTECTION OF HUMAN HEALTH – CARCINOGENS</b>					
Acrolein	µg/L	--	--	--	1.94E+04
	lb/day	--	--	--	5.81E+02
Antimony	µg/L	--	--	--	1.06E+05
	lb/day	--	--	--	3.17E+03
Bis(2-chloroethoxy) Methane	µg/L	--	--	--	3.87E+02
	lb/day	--	--	--	1.16E+01
Bis(2-chloroisopropyl) Ether	µg/L	--	--	--	1.06E+05
	lb/day	--	--	--	3.17E+03
Chlorobenzene	µg/L	--	--	--	5.02E+04
	lb/day	--	--	--	1.51E+03
Chromium (III), Total Recoverable	µg/L	--	--	--	1.67E+07
	lb/day	--	--	--	5.02E+05
Di-n-butyl Phthalate	µg/L	--	--	--	3.08E+05
	lb/day	--	--	--	9.25E+03
Dichlorobenzenes <sup>5</sup>	µg/L	--	--	--	4.49E+05
	lb/day	--	--	--	1.35E+04
Diethyl Phthalate	µg/L	--	--	--	2.90E+06
	lb/day	--	--	--	8.72E+04
Dimethyl Phthalate	µg/L	--	--	--	7.22E+07
	lb/day	--	--	--	2.17E+06
4,6-dinitro-2-methylphenol	µg/L	--	--	--	1.94E+04
	lb/day	--	--	--	5.81E+02
2,4-dinitrophenol	µg/L	--	--	--	3.52E+02
	lb/day	--	--	--	1.06E+01
Ethylbenzene	µg/L	--	--	--	3.61E+05

Parameter	Unit	Performance Goals <sup>1</sup>			
		6-Month Median	Maximum Daily	Instantaneous Maximum	30-Day Average
Fluoranthene	lb/day	--	--	--	1.08E+04
	µg/L	--	--	--	1.32E+03
	lb/day	--	--	--	3.96E+01
Hexachlorocyclopentadiene	µg/L	--	--	--	5.10E+03
	lb/day	--	--	--	1.53E+02
Nitrobenzene	µg/L	--	--	--	4.31E+02
	lb/day	--	--	--	1.29E+01
Thallium, Total Recoverable	µg/L	--	--	--	1.76E+02
	lb/day	--	--	--	5.28E+00
Toluene	µg/L	--	--	--	7.48E+06
	lb/day	--	--	--	2.25E+05
Tributyltin	µg/L	--	--	--	1.23E-01
	lb/day	--	--	--	3.70E-03
1,1,1-trichloroethane	µg/L	--	--	--	4.75E+07
	lb/day	--	--	--	1.43E+06
<b>BASED ON OBJECTIVES FOR PROTECTION OF HUMAN HEALTH - CARCINOGENS</b>					
Acrylonitrile	µg/L	--	--	--	8.80E+00
	lb/day	--	--	--	2.64E-01
Aldrin	µg/L	--	--	--	1.94E-03
	lb/day	--	--	--	5.81E-05
Benzene	µg/L	--	--	--	5.19E+02
	lb/day	--	--	--	1.56E+01
Benzidine	µg/L	--	--	--	6.07E-03
	lb/day	--	--	--	1.82E-04
Beryllium	µg/L	--	--	--	2.90E+00
	lb/day	--	--	--	8.72E-02
Bis(2-chloroethyl) Ether	µg/L	--	--	--	3.96E+00
	lb/day	--	--	--	1.19E-01
Bis(2-ethylhexyl) Phthalate	µg/L	--	--	--	3.08E+02
	lb/day	--	--	--	9.25E+00
Carbon Tetrachloride	µg/L	--	--	--	7.92E+01
	lb/day	--	--	--	2.38E+00
Chlorodane	µg/L	--	--	--	2.02E-03
	lb/day	--	--	--	6.08E-05
Chlorodibromomethane	µg/L	--	--	--	7.57E+02
	lb/day	--	--	--	2.27E+01
Chloroform	µg/L	--	--	--	1.14E+04
	lb/day	--	--	--	3.43E+02

Parameter	Unit	Performance Goals <sup>1</sup>			
		6-Month Median	Maximum Daily	Instantaneous Maximum	30-Day Average
DDT <sup>6</sup>	µg/L	--	--	--	1.50E-02
	lb/day	--	--	--	4.49E-04
1,4-dichlorobenzene	µg/L	--	--	--	1.58E+03
	lb/day	--	--	--	4.76E+01
3,3'-dichlorobenzidine	µg/L	--	--	--	7.13E-01
	lb/day	--	--	--	2.14E-02
1,2-dichloroethane	µg/L	--	--	--	2.46E+03
	lb/day	--	--	--	7.40E+01
1,1-dichloroethylene	µg/L	--	--	--	7.92E+01
	lb/day	--	--	--	2.38E+00
Dichlorobromomethane	µg/L	--	--	--	5.46E+02
	lb/day	--	--	--	1.64E+01
Dichloromethane	µg/L	--	--	--	3.96E+04
	lb/day	--	--	--	1.19E+03
1,3-dichloropropene	µg/L	--	--	--	7.83E+02
	lb/day	--	--	--	2.35E+01
Dieldrin	µg/L	--	--	--	3.52E-03
	lb/day	--	--	--	1.06E-04
2,4-dinitrotoluene	µg/L	--	--	--	2.29E+02
	lb/day	--	--	--	6.87E+00
1,2-diphenylhydrazine	µg/L	--	--	--	1.41E+01
	lb/day	--	--	--	4.23E-01
Halomethanes <sup>7</sup>	µg/L	--	--	--	1.14E+04
	lb/day	--	--	--	3.43E+02
Heptachlor	µg/L	--	--	--	4.40E-03
	lb/day	--	--	--	1.32E-04
Heptachlor Epoxide	µg/L	--	--	--	1.76E-03
	lb/day	--	--	--	5.28E-05
Hexachlorobenzene	µg/L	--	--	--	1.85E-02
	lb/day	--	--	--	5.55E-04
Hexachlorobutadiene	µg/L	--	--	--	1.23E+03
	lb/day	--	--	--	3.70E+01
Hexachloroethane	µg/L	--	--	--	2.20E+02
	lb/day	--	--	--	6.61E+00
Isophorone	µg/L	--	--	--	6.42E+04
	lb/day	--	--	--	1.93E+03
N-nitrosodimethylamine	µg/L	--	--	--	6.42E+02
	lb/day	--	--	--	1.93E+01



Parameter	Unit	Performance Goals <sup>1</sup>			
		6-Month Median	Maximum Daily	Instantaneous Maximum	30-Day Average
N-nitrosodi-N-propylamine	µg/L	--	--	--	3.34E+01
	lb/day	--	--	--	1.00E+00
N-nitrosodiphenylamine	µg/L	--	--	--	2.20E+02
	lb/day	--	--	--	6.61E+00
PAHs <sup>8</sup>	µg/L	--	--	--	7.74E-01
	lb/day	--	--	--	2.33E-02
PCBs <sup>9</sup>	µg/L	--	--	--	1.67E-03
	lb/day	--	--	--	5.02E-05
TCDD equivalents <sup>10</sup>	µg/L	--	--	--	3.43E-07
	lb/day	--	--	--	1.03E-08
1,1,2,2-tetrachloroethane	µg/L	--	--	--	2.02E+02
	lb/day	--	--	--	6.08E+00
Tetrachloroethylene	µg/L	--	--	--	1.76E+02
	lb/day	--	--	--	5.28E+00
Toxaphene	µg/L	--	--	--	1.85E-02
	lb/day	--	--	--	5.55E-04
Trichloroethylene	µg/L	--	--	--	2.38E+03
	lb/day	--	--	--	7.13E+01
1,1,2-trichloroethane	µg/L	--	--	--	8.27E+02
	lb/day	--	--	--	2.48E+01
2,4,6-trichlorophenol	µg/L	--	--	--	2.55E+01
	lb/day	--	--	--	7.66E-01
Vinyl Chloride	µg/L	--	--	--	3.17E+03
	lb/day	--	--	--	9.51E+01

<sup>1</sup> Scientific "E" notation is used to express certain values. In scientific "E" notation, the number following the "E" indicates that position of the decimal point in the value. Negative numbers after the "E" indicate that the value is less than 1, and positive numbers after the "E" indicate that the value is greater than 1. In this notation a value of 6.1E-02 represents  $6.1 \times 10^{-2}$  or 0.061, 6.1E+02 represents  $6.1 \times 10^2$  or 610, and 6.1E+00 represents  $6.1 \times 10^0$  or 6.1.

<sup>2</sup> Dischargers may, at their option, meet this limitation (or apply this performance goal) as a total chromium limitation (or performance goal).

<sup>3</sup> If a Discharger can demonstrate to the satisfaction of the Regional Water Board (subject to USEPA approval) that an analytical method is available to reliably distinguish between strongly and weakly complexed cyanide, effluent limitations for cyanide may be met by (or performance goals may be evaluated with) the combined measurement of free cyanide, simple alkali metals cyanides, and weakly complexed organometallic cyanide complexes. In order for the analytical method to be acceptable, the recovery of free cyanide from metal complexes must be comparable to that achieved by the approved method in 40 CFR 136, as revised May 14, 1999.

<sup>4</sup> HCH (hexachlorocyclohexane) represents the sum of the alpha, beta, gamma (Lindane), and delta isomers of hexachlorocyclohexane.

<sup>5</sup> Dichlorobenzenes represent the sum of 1,2- and 1,3-dichlorobenzene.

<sup>6</sup> DDD (dichlorodiphenyldichloroethane), DDE (dichlorodiphenyldichloroethylene), and DDT (dichlorodiphenyltrichloroethane) represent the sum of 4,4'DDT; 2,4'DDT; 4,4'DDE; 2,4'DDE; 4,4'DDD; and 2,4'DDD.

- <sup>7</sup> Halomethanes represent the sum of bromoform, bromomethane (methyl bromide), and chloromethane (methyl chloride).
- <sup>8</sup> PAHs (polynuclear aromatic hydrocarbons) represent the sum of acenaphthalene; anthracene; 1,2-benzanthracene; 3,4-benzofluoranthene; benzo[k]fluoranthene; 1,1,2-benzoperylene; benzo[a]pyrene; chrysene; dibenzo[a,h]anthracene; fluorine; indeno[1,2,3-cd]pyrene; phenanthrene; and pyrene.
- <sup>9</sup> PCBs (polychlorinated biphenyls) represent the sum of chlorinated biphenyls whose analytical characteristics resemble those of Aroclor-1016, Aroclor-1221, Aroclor-1232, Aroclor-1242, Aroclor-1248, Aroclor-1254, and Aroclor-1260.
- <sup>10</sup> TCDD equivalents represent the sum of concentrations of chlorinated dibenzodioxins (2,3,7,8-CDDs) and chlorinated dibenzofurans (2,3,7,8-CDFs) multiplied by their respective toxicity factors, as shown by the table below. USEPA Method 8280 may be used to analyze TCDD equivalents.

Isomer Group	Toxicity Equivalence Factor
2,3,7,8 – tetra CDD	1.0
2,3,7,8 – penta CDD	0.5
2,3,7,8 – hexa CDD	0.1
2,3,7,8 – hepta CDD	0.01
octa CDD	0.001
2,3,7,8 – tetra CDF	0.1
1,2,3,7,8 – penta CDF	0.05
2,3,4,7,8 – penta CDF	0.5
2,3,7,8 – hexa CDFs	0.1
2,3,7,8 – hepta CDFs	0.01
Octa CDF	0.001

- <sup>11</sup> Endosulfan shall mean the sum of alpha-endosulfan, beta-endosulfan, and endosulfan sulfate.

## **2. Interim Effluent Limitations – Not Applicable**

### **B. Land Discharge Specifications – Not Applicable**

### **C. Reclamation Specifications – Not Applicable**

## V. RECEIVING WATER LIMITATIONS

Unless specifically excepted by this Order, the discharge, by itself or jointly with any other discharge(s), shall not cause violation of the numerical water quality objectives established in Chapter II, Table B of the Ocean Plan and shall not cause a violation of the following water quality objectives. Compliance with these objectives shall be determined by samples collected at stations representative of the area within the waste field where initial dilution is completed.

### A. Surface Water Limitation

Receiving water limitations are based on water quality objectives contained in the Basin Plan and Ocean Plan and are a required part of this Order. The discharge shall not cause the following in the Pacific Ocean.

#### 1. Bacterial Characteristics

- a. Within a zone bounded by the shoreline and a distance of 1,000 feet from the shoreline or the 30-foot depth contour, whichever is further from the shoreline, and in areas outside this zone used for water contact sports, as determined by the Regional Water Board, but including all kelp beds, the following bacterial objectives shall be maintained throughout the water column.
  - i. 30-day Geometric Mean – The following standards are based on the geometric mean of the five most recent samples from each site:
    - 1) Total coliform density shall not exceed 1,000 per 100 ml;
    - 2) Fecal coliform density shall not exceed 200 per 100 ml; and
    - 3) Enterococcus density shall not exceed 35 per 100 ml.
  - ii. Single Sample Maximum:
    - 1) Total coliform density shall not exceed 10,000 per 100 ml;
    - 2) Fecal coliform density shall not exceed 400 per 100 ml;
    - 3) Enterococcus density shall not exceed 104 per 100 ml; and
    - 4) Total coliform density shall not exceed 1,000 per 100 ml when the fecal coliform/total coliform ratio exceeds 0.1.
- b. The Initial Dilution Zone for any wastewater outfall shall be excluded from designation as kelp beds for purposes of bacterial standards. Adventitious assemblages of kelp plants on waste discharge structures (e.g., outfall pipes and diffusers) do not constitute kelp beds for purposes of bacterial standards.

- c. At all areas where shell fish may be harvested for human consumption, as determined by the Regional Water Board, the median total coliform density shall not exceed 70 per 100 ml throughout the water column, and not more than 10 percent of the samples shall exceed 230 per 100 ml.
- d. For marine waters beyond the outer limit of territorial seas, the ocean water shall not exceed a 30-day geometric mean for enterococcus density of 35 per 100 ml and a single sample maximum of 104 per 100 ml.

## 2. Physical Characteristics

- a. Floating particulates and grease and oils shall not be visible.
- b. The discharge of waste shall not cause aesthetically undesirable discoloration of the ocean surface.
- c. Natural light shall not be significantly reduced at any point outside the initial dilution zone as a result of the discharge of waste.
- d. The rate of deposition of inert solids and the characteristics of inert solids in the ocean sediments shall not be changed such that benthic communities are degraded.

## 3. Chemical Characteristics

- a. The dissolved oxygen concentration shall not at any time be depressed more than 10 percent from that which occurs naturally, as the result of the discharge of oxygen demanding waste materials.
- b. The pH shall not be changed at any time more than 0.2 units from that which occurs naturally.
- c. The dissolved sulfide concentration of waters in and near sediments shall not be significantly increased above that present under natural conditions.
- d. The concentration of substances set forth in Chapter II, Table B of the Ocean Plan, shall not be increased in marine sediments to levels that would degrade indigenous biota.
- e. The concentration of organic materials in marine sediments shall not be increased to levels that would degrade marine life.
- f. Nutrient materials shall not cause objectionable aquatic growths or degrade indigenous biota.

## 4. Biological Characteristics

- a. Marine communities, including vertebrate, invertebrate, and plant species, shall not be degraded.

- b.** The natural taste, odor, color of fish, shellfish, or other marine resources used for human consumption shall not be altered.
- c.** The concentration of organic materials in fish, shellfish, or other marine resources used for human consumption shall not bioaccumulate to levels that are harmful to human health.

**5. Radioactivity**

- a.** Discharge of radioactive waste shall not degrade marine life.

**B. Groundwater Limitations – Not Applicable**

## VI. PROVISIONS

### A. Standard Provisions

1. **Federal Standard Provisions.** The Discharger shall comply with all Standard Provisions included in Attachment D of this Order.
2. **Regional Water Board Standard Provisions.** The Discharger shall comply with the following provisions:
  - a. Compliance with Ocean Plan Discharge Prohibitions, summarized in Attachment G is required as a condition of this Order and permit.
  - b. Compliance with Discharge Prohibitions contained in Chapter 4 of the Basin Plan, summarized in Attachment G, is required as a condition of this Order and permit.
  - c. The Discharger shall comply with all requirements and conditions of this Order. Any permit noncompliance constitutes a violation of the CWA and/or the CWC and is grounds for enforcement action, permit termination, revocation and reissuance, or modification, or for denial of an application for permit renewal, modification, or reissuance.
  - d. The Discharger shall comply with all applicable federal, State, and local laws and regulations that pertain to sewage sludge handling, treatment, use and disposal, including CWA Section 405 and USEPA regulations at 40 CFR Part 257.
  - e. The Discharger's wastewater treatment facilities shall be supervised and operated by persons possessing certificates of appropriate grade pursuant to Title 23, Division 3, Chapter 26 of the California Code of Regulations (CCRs).
  - f. All proposed new treatment facilities and expansions of existing treatment facilities shall be completely constructed and operable prior to initiation of the discharge from the new or expanded facilities. The Discharger shall submit a certification report for each new treatment facility, expansion of an existing treatment facility, and re-ratings, the certification report shall be prepared by the design engineer. For re-ratings, the certification report shall be prepared by the engineer who evaluated the treatment facility capacity. The certification report shall:
    - i. Identify the design capacity of the treatment facility, including the daily and 30-day design capacity,
    - ii. Certify the adequacy of each component of the treatment facility, and
    - iii. Contain a requirement-by-requirement analysis, based on acceptable engineering practices, of the process and physical design of the facility to ensure compliance with this Order.

- The signature and engineering license number of the engineer preparing the certification report shall be affixed to the report. If reasonable, the certification report shall be submitted prior to beginning construction. The Discharger shall not initiate a discharge from an existing treatment facility at a daily flow rate in excess of its previously approved design capacity until:
- i.** The certification report is received by the Executive Officer,
  - ii.** The Executive Officer has received written notification of completion of construction (new treatment facilities and expansions only),
  - iii.** An inspection of the facility has been made by staff of the Regional Water Board or their designated representatives (new treatment facilities and expansions only), and
  - iv.** The Executive Officer has provided the Discharger with written authorization to discharge at a daily flow rate in excess of its previously approved design capacity.
- g.** All waste treatment, containment, and disposal facilities shall be protected against 100-year peak stream flows as defined by the San Diego County flood control agency.
- h.** All waste treatment, containment, and disposal facilities shall be protected against erosion, overland runoff, and other impacts resulting from a 100-year, 24-hour storm event.
- i.** This Order expires on November 1, 2013, after which, the terms and conditions of this permit are automatically continued pending issuance of a new permit, provided that all requirements of USEPA's NPDES regulations at 40 CFR 122.6 and the State's regulations at CCR Title 23, Section 2235.4 regarding the continuation of expired permits and waste discharge requirements are met.
- j.** The Discharger's wastewater treatment facilities shall be operated and maintained in accordance with the operations and maintenance manual prepared by the Discharger pursuant to the Clean Water Grant Program.
- k.** A copy of this Order shall be posted at a prominent location at or near the treatment and disposal facilities and shall be available to operating personnel at all times.
- l.** The Discharger shall comply with any interim limitations established by addendum, enforcement action, or revised waste discharge requirements that have been or may be adopted by the Regional Water Board.
- m.** The Discharger shall comply with effluent standards and prohibitions for toxic pollutants established pursuant to section 307(a) of the CWA within the time frame set forth by the regulations that establish those standards and prohibitions,

even if this Order has not been modified to incorporate the requirements. If an applicable effluent standard or prohibition, including any schedule of compliance, is promulgated pursuant to section 307 (d) of the CWA for a toxic pollutant, and that standard or prohibition is more stringent than a limitation contained in this Order, the Executive Officer may institute proceedings to modify or revoke and reissue the Order to conform to the effluent standard or prohibition.

## **B. Monitoring and Reporting Program (MRP) Requirements**

The Discharger shall comply with the MRP, and future revisions thereto, in Attachment E of this Order.

## **C. Special Provisions**

### **1. Reopener Provisions**

- a.** This Order may be reopened for modification to include an effluent limitation if monitoring establishes that the discharge causes, has the reasonable potential to cause, or contributes to an excursion above an Ocean Plan Table B water quality objective.
- b.** This Order may be modified, revoked and reissued, or terminated for cause including, but not limited to, the following;
  - i.** Violation of any terms or conditions of this Order.
  - ii.** Obtaining this Order by misrepresentation or failure to disclose fully all relevant fact, or
  - iii.** A change in any condition that requires either a temporary or permanent reduction or elimination of the authorized discharge.

The filing of a request by the Discharger for modifications, revocation and reissuance, or termination of this Order does not stay any condition of this Order. Notification by the Discharger of planned operational or facility changes, or anticipated noncompliance with this Order does not stay any condition of this Order.

- c.** If any applicable toxic effluent standard or prohibition (including any schedule of compliance specified in such effluent standard or prohibition) is promulgated under section 307(a) of the CWA for a toxic pollutant and that standard or prohibition is more stringent than any limitation on the pollutant in this Order, the Regional Water Board may institute proceedings under these regulations to modify or revoke and reissue the Order to conform to the toxic effluent standard or prohibition.
- d.** This Order may be re-opened and modified, to incorporate in accordance with the provisions set forth in 40 CFR Parts 122 and 124, to include requirements for the implementation of the watershed management approach.



- e. This Order may be reopened and modified, in accordance with the provisions set forth in 40 CFR Parts 122 and 124, to include new Minimum Levels (MLs).
- f. This Order may be re-opened and modified to revise effluent limitations as a result of future Basin Plan Amendments, or the adoption of a total maximum daily load allocation (TMDL) for the receiving water.
- g. This Order may be re-opened upon submission by the Discharger of adequate information, as determined by this Regional Water Board, to provide for dilution credits or a mixing zone, as may be appropriate.
- h. This Order may be re-opened and modified to revise the toxicity language once that language becomes standardized.
- i. This Order may also be re-opened and modified, revoked and, reissued or terminated in accordance with the provisions of 40 CFR sections 122.44, 122.62 to 122.64, 125.62, and 125.62. Causes for taking such actions include, but are not limited to, failure to comply with any condition of this Order and permit, and endangerment to human health or the environment resulting from the permitted activity.

## **2. Special Studies, Technical Reports and Additional Monitoring Requirements**

The Discharger may be requested to participate in special studies. Special studies differ from other elements of the monitoring program in that they are intended to be short-term and are designated to address specific research or management issues that are not addressed by the routine core monitoring elements.

### **a. Toxicity Reduction Requirements**

If the discharge consistently exceeds an effluent limitation or performance goal for toxicity specified in section IV.A.1, the Discharger shall conduct a Toxicity Reduction Evaluation (TRE) defined in Attachment A. The TRE shall include all reasonable steps to identify the source of toxicity. The Discharger shall take all reasonable steps to reduce toxicity to the required level once the source of toxicity is identified.

If the toxicity testing result shows an exceedance of the acute toxicity performance goal or chronic toxicity effluent limitation, the Discharger shall:

- i. Take all reasonable measures necessary to immediately minimize toxicity; and
- ii. Increase the frequency of the toxicity test(s) that showed a violation to at least two times per month until the results of at least two consecutive toxicity tests do not show violations.

The additional toxicity tests will be incorporated into the monthly discharge monitoring report within one month after the completion of the accelerated monitoring and submitted to the Regional Water Board pursuant to Attachment E.

If the additional tests indicate that toxicity effluent limitations are being consistently violated (at least three exceedances out of six tests), the Discharger shall conduct a Toxicity Reduction Evaluation (TRE) and a Toxic Identification Evaluation (TIE). Once the source of toxicity is identified, the Discharger shall take all reasonable steps to reduce the toxicity to meet the toxicity limitations identified in section IV.A.1 of this Order.

Within 30 days of completion of the TRE/TIE, the Discharger shall submit the results of the TRE/TIE, including a summary of the findings, data generated, a list of corrective actions necessary to achieve consistent compliance with all the toxicity limitations/performance goals of this Order and prevent recurrence of exceedances of those limitations/performance goals, and a time schedule for implementation of such corrective actions. The corrective actions and time schedule shall be modified at the direction of the Executive Officer.

**b. Toxicity Reduction Evaluation (TRE)**

The Discharger shall develop a TRE workplan in accordance with TRE procedures established by the USEPA in the following guidance manuals.

- i. Generalized Methodology for Conducting Industrial Toxicity Reduction Evaluations (EPA/600/2-88/070).
- ii. Toxicity Identification Evaluation, Phase I (EPA/600/6-91/005F).
- iii. Methods for Aquatic Toxicity Identification Evaluations, Phase II (EPA/600/R-92/080).
- iv. Methods for Aquatic Toxicity Identification Evaluations, Phase III (EPA/600/R-92/081).

The Discharger shall submit the TRE workplan to the Regional Water Board within 180 days of the adoption of this Order. The TRE workplan shall be subject to the approval of the Regional Water Board and shall be modified as directed by the Regional Water Board.

**3. Best Management Practices and Pollution Prevention – Not Applicable**

**4. Construction, Operation and Maintenance Specifications – Not Applicable**

**5. Special Provisions for Municipal Facilities (POTWs Only)**

**a. Treatment Plant Capacity**

The Discharger shall submit a written report to the Executive Officer within 90 days after the monthly average influent flow rate equals or exceeds 75 percent of the secondary treatment design capacity of the wastewater treatment and/or disposal facilities. The Discharger's senior administrative officer shall sign a letter in accordance with Standard Provision V.B. (Attachment D) which transmits that report and certifies that that policy-making body is adequately informed of the influent flow rate relative to the Facility's design capacity. The report shall include the following:

- i. Average influent daily flow for the calendar month; the date on which the maximum daily flow occurred; and the rate of that maximum flow.
- ii. The Discharger's best estimate of when the average daily influent flow for a calendar month will equal or exceed the design capacity of the facilities.
- iii. The Discharger's intended schedule for studies, design, and other steps needed to provide additional treatment for the wastewater from the collection system before the waste flow exceeds the capacity of present units.

## **b. Source Control Program Requirements**

### **i. Source Control Program**

The Discharger shall develop and implement a source control program to control the discharge of non-domestic pollutants to its sanitary sewer system and its treatment facilities. This source control program shall be implemented to prevent:

- (a) The pass-through of pollutants or any interference with wastewater treatment plant operations from any pollutant, including BOD, excessive heat, oil and grease, metals, and organics that may result in the violation of discharge requirements (including effluent limitations) contained in this Order;
- (b) Sludge contamination that interferes with the disposal of sludge in accordance with 40 CFR 503 and as specified in section c below.
- (c) The introduction of pollutants which could create a fire or explosion hazard in the sanitary sewer system or the treatment plant, including waste streams with a closed cup flashpoint of less than 140 degrees °F using test methods specified in 40 CFR 261.21; and
- (d) The introduction of pollutants which could cause corrosive structural damage, obstructions in flow, or the formation of toxic gases and fumes in a quantity that could cause acute worker health and safety problems.

### **ii. Annual Industrial Waste Survey**

- (a) The Discharger shall conduct an annual Industrial Waste Survey (IWS) of all non-domestic facilities in the service area of the permitted treatment plant to determine whether any such facilities may be contributing to violations of the discharge requirements specified in the Order. As part of the IWS, the Discharger shall conduct an influent priority pollutant scan at the treatment plant. A copy of the annual IWS report shall be submitted to the Regional Water Board by March 1, of each year.
- (b) Based on the results of the IWS, the Regional Water Board may amend this Order to require non-domestic discharges adversely impacting the performance of the treatment plant be made subject to applicable provisions in the federal regulations which require the control of pollutant discharges using best available technology economically achievable (BAT) and best conventional pollutant control technology (BCT) to prevent and/or reduce pollutants.

### **iii. Domestic Discharger Source Control Program**

The Discharger shall implement a domestic discharger Source Control Program consisting of a public education program designed to minimize the entrance of domestic toxic pollutants into the sanitary sewer system. Annually the domestic source control program shall be reviewed and, if necessary, updated.

### **iv. Treatment Plant Influent Monitoring Program**

The Discharger shall implement a treatment plant influent monitoring program as specified in Attachment E (MRP).

### **v. Special Requirements for Facilities using Oil/Water Separators**

- (a) All non-domestic facilities with the potential to discharge oil and other petroleum products, such as vehicle maintenance facilities, shall be equipped with an oil/water separator (OWS) to handle peak hydraulic loads and to reduce plant influent from containing free oil, or oil and grease at a levels that will adversely impact the operation and maintenance of the treatment plant.
- (b) All OWS serving active facilities shall be visually inspected once per week to insure proper operation and removal of accumulated oil. The inspection may be performed by facility personnel or other responsible agency. A signed written log shall be kept documenting each inspection. The operation of any malfunctioning OWS must cease until it has received proper maintenance.

### **vi. Special Requirements for Facilities Discharging Silver**

Best Management Practices, such as the installation of silver recovery units shall be implemented to control the discharge of non-domestic waste containing silver.

**vii. Special Requirements for Dining Facilities and Commercial Restaurants**

Best Management Practices, such as the installation and maintenance of grease traps, shall be implemented to control the discharge of non-domestic waste containing oil and grease.

**c. Sludge (Biosolids) Disposal Requirements**

- i. The handling, treatment, use, management, and disposal of sludge and solids derived from wastewater treatment must comply with applicable provisions of CWA section 405 and USEPA regulations at 40 CFR parts 257, 258, 501, and 503, including all monitoring, record keeping, and reporting requirements.
- ii. Sludge and wastewater solids must be disposed of in a municipal solid waste landfill, reused by land application, or disposed of in a sludge-only landfill in accordance with 40 CFR Parts 258 and 503 and Title 23, Chapter 15 of the CCRs. If the Discharger desires to dispose of solids and/or sludge in a different manner, a request for permit modification must be submitted to the USEPA and to this Regional Water Board at least 180 days prior to beginning the alternative means of disposal.
- iii. Sludge that is disposed of in a municipal solid waste landfill must meet the requirements of 40 CFR 25 pertaining to providing information to the public. In the annual self-monitoring report, the Discharger shall include the amount of sludge placed in the landfill as well as the landfill to which it was sent.
- iv. All requirements of 40 CFR 503 and 23 CCR Chapter 15 are enforceable whether or not the requirements of those regulations are stated in an NPDES permit or any other permit issued to the Discharger.
- v. The Discharger shall take all reasonable steps to prevent and minimize any sludge use or disposal in violation of this Order that has a likelihood of adversely affecting human health or the environment.
- vi. Solids and sludge treatment, storage, and disposal or reuse shall not create a nuisance, such as objectionable odors or flies, and shall not result in groundwater contamination.
- vii. The solids and sludge treatment and storage site shall have adequate facilities to divert surface water runoff from adjacent areas to protect the boundaries of the site from erosion, and to prevent drainage from the treatment and storage site. Adequate protection is defined as protection, at the minimum, from a 100-year storm and protection from the highest possible tidal stage that may occur.

**viii.** The discharge of sewage sludge and solids shall not cause waste material to be in position where it is, or can be, conveyed from the treatment and storage sites and deposited in waters of the State.

**ix.** The Discharger shall submit an annual report to the USEPA and the Regional Water Board containing monitoring results and pathogen and vector attraction reduction requirements, as specified by 40 CFR 503. The Discharger shall also report the quantity of sludge removed from the Facility and the disposal method. This self-monitoring report shall be postmarked by February 1 of each year and report for the period of the previous calendar year.

**d. Sanitary Sewer System Requirements**

The Discharger shall comply with the sanitary sewer system requirements specified in Attachment H to this Order.

**6. Other Special Provisions – Not Applicable**

**7. Compliance Schedules – Not Applicable**

## **VII. COMPLIANCE DETERMINATION**

Compliance with the effluent limitations contained in section IV of this Order will be determined as specified below:

### **A. Compliance with Average Monthly Effluent Limitation (AMEL)**

If the average of daily discharges over a calendar month exceeds the AMEL for a given parameter, an alleged violation will be flagged and the Discharger will be considered out of compliance for each day of that month for that parameter (e.g., resulting in 31 days of noncompliance in a 31-day month). The average of daily discharges over the calendar month that exceeds the AMEL for a parameter will be considered out of compliance for the month only. If only a single sample is taken during the calendar month and the analytical result for that sample exceeds the AMEL, the Discharger will be considered out of compliance for that calendar month. For any one calendar month during which no sample (daily discharge) is taken, no compliance determination can be made for that calendar month.

### **B. Compliance with Average Weekly Effluent Limitation (AWEL)**

If the average of daily discharges over a calendar week (Sunday through Saturday) exceeds the AWEL for a given parameter, an alleged violation will be flagged and the Discharger will be considered out of compliance for each day of that week for that parameter, resulting in 7 days of noncompliance. The average of daily discharges over the calendar week that exceeds the AWEL for a parameter will be considered out of compliance for that week only. If only a single sample is taken during the calendar week and the analytical result for that sample exceeds the AWEL, the Discharger will be considered out of compliance for that calendar week. For any one calendar week during which no sample (daily discharge) is taken, no compliance determination can be made for that calendar week.

### **C. Compliance with Maximum Daily Effluent Limitation (MDEL)**

The MDEL shall apply to flow weighted 24-hour composite samples. If a daily discharge exceeds the MDEL for a given parameter, an alleged violation will be flagged and the Discharger will be considered out of compliance for that parameter for that one day only within the reporting period. For any one day during which no sample is taken, no compliance determination can be made for that day.

### **D. Compliance with Instantaneous Minimum Effluent Limitation**

The instantaneous minimum effluent concentration limitation shall apply to grab sample determinations. If the analytical result of a single grab sample is lower than the instantaneous minimum effluent limitation for a parameter, a violation will be flagged and the Discharger will be considered out of compliance for that parameter for that single sample. Non-compliance for each sample will be considered separately (e.g., the results of two grab samples taken within a calendar day that both are lower than the

instantaneous minimum effluent limitation would result in two instances of noncompliance with the instantaneous minimum effluent limitation.

#### **E. Compliance with Instantaneous Maximum Effluent Limitation**

The instantaneous maximum effluent concentration limitation shall apply to grab sample determinations. If the analytical result of a single grab sample is higher than the instantaneous maximum effluent limitation for a parameter, a violation will be flagged and the Discharger will be considered out of compliance for that parameter for that single sample. Non-compliance for each sample will be considered separately (e.g., the results of two grab samples taken within a calendar day that both exceed the instantaneous maximum effluent limitation would result in two instances of noncompliance with the instantaneous maximum effluent limitation).

#### **F. Compliance with Six-month Median Effluent Limitation**

If the median of daily discharges over any 180-day period exceeds the six-month median effluent limitation for a given parameter, an alleged violation will be flagged and the Discharger will be considered out of compliance for each day of that 180-day period for that parameter. The next assessment of compliance will occur after the next sample is taken. If only a single sample is taken during a given 180-day period and the analytical result for that sample exceeds the six-month median, the Discharger will be considered out of compliance for the 180-day period. For any 180-day period during which no sample is taken, no compliance determination can be made for the six-month median limitation.

#### **G. Mass and Concentration Limitations**

Compliance with mass and concentration effluent limitations for the same parameter shall be determined separately with their respective limitations. When the concentration of a constituent in an effluent sample is determined to be "Not Detected" (ND) or "Detectable but not quantifiable" (DNQ), the corresponding mass emission rate (MER) determined from that sample concentration shall also be reported as "ND" or "DNQ".

#### **H. Percent Removal**

Compliance with percent removal requirements for monthly average percent removal of biochemical oxygen demand and total suspended solids shall be determined separately for each wastewater treatment facility discharging through an outfall. For each wastewater treatment facility, the monthly average percent removal is the average of the calculated daily discharge percent removals only for days on which the constituent concentration is monitored in both the influent and effluent of the wastewater treatment facility at location specified in the Monitoring and Reporting Program (Attachment E) within a calendar month.

The percent removal for each day shall be calculated according to the following equation:



$$\text{Daily discharge percent removal} = \frac{\text{Influent concentration} - \text{Effluent concentration}}{\text{Influent concentration}} \times 100\%$$

## I. 2005 California Ocean Plan Provisions for Table B Constituents

### 1. Sampling Reporting Protocols

- b. Dischargers must report with each sample result the reported ML and the laboratory's current Method Detection Limit (MDL).
- c. Dischargers must also report results of analytical determinations for the presence of chemical constituents in a sample using the following reporting protocols:
  - i. Sample results greater than or equal to the reported ML must be reported "as measured" by the laboratory (i.e., the measured chemical concentration in the sample).
  - ii. Sample results less than the reported ML, but greater than or equal to the laboratory's MDL, must be reported as "Detected, but Not Quantified", or DNQ. The laboratory must write the estimated chemical concentration of the sample next to DNQ as well as the words "Estimated Concentration" (may be shorted to Est. Conc.).
  - iii. Sample results less than the laboratory's MDL must be reported as "Not Detected", or ND.

### 2. Compliance Determination

Sufficient sampling and analysis shall be required to determine compliance with the effluent limitation.

#### a. Compliance with Single-constituent Effluent Limitations

The Discharger shall be deemed out of compliance with an effluent limitation or discharge specification if the concentration of the constituent in the monitoring sample is greater than the effluent limitation or discharge specification and greater than or equal to the ML.

#### b. Compliance with Effluent Limitations Expressed as a Sum of Several Constituents

Dischargers are out of compliance with an effluent limitation that applies to the sum of a group of chemicals (e.g., PCBs) if the sum of the individual pollutant concentrations is greater than the effluent limitation. Individual pollutants of the group will be considered to have a concentration of zero if the constituent is reported as ND or DNQ.

### **c. Multiple Sample Data Reduction**

The concentration of the pollutant in the effluent may be estimated from the result of a single sample analysis or by a measure of central tendency (arithmetic mean, geometric mean, median, etc.) of multiple sample analyses when all sample results are quantifiable (i.e., greater than or equal to the reported ML). When one or more sample results are reported as ND or DNQ, the central tendency concentration of the pollutant shall be the median (middle) value of the multiple samples. If, in an even number of samples, one or both of the middle values is ND or DNQ, the median will be the lower of the two middle values.

### **d. Acute Toxicity**

Compliance with the Acute Toxicity Performance Goal for Discharge Point No. 001 shall be determined using an established protocol, e.g., COP 2005, American Society for Testing Materials (ASTM), USEPA, American Public Health Association, or State Water Board. Acute Toxicity shall be expressed in Toxic Units Acute ( $TU_a$ ), where:

$$TU_a = 100/96\text{-hr } LC_{50}$$

and where  $LC_{50}$  is the Lethal Concentration 50%; the percent waste giving 50% survival of test organisms.  $LC_{50}$  shall be determined by static or continuous flow bioassay techniques using standard test species. If specific identifiable substances in wastewater can be demonstrated by the Discharger as being rapidly rendered harmless upon discharge to the marine environment, but not as a result of dilution, the  $LC_{50}$  may be determined after the test samples are adjusted to remove the influence of those substance.

When it is not possible to measure the 96-hour  $LC_{50}$  due to greater than 50% survival of the test species in 100% waste, the toxicity concentration shall be calculated by the following:

$$TU_a = \log(100-S)/1.7$$

where S is the percent survival in 100% waste. If  $S > 99$ ,  $TU_a$  shall be reported as zero.

### **e. Mass Emission Rate**

The mass emission rate (MER), in pounds per day, shall be obtained from the following calculation for any calendar day:

$$\text{Mass Emission Rate (lb/day)} = 8.34 \times Q \times C$$

In which Q and C are the flow rate in million gallons per day, and the constituent concentration in mg/L, respectively, and 8.34 is a conversion factor (lb/gallon of

water). If a composite sample is taken, then C is the concentration measured in the composite sample and Q is the average flow rate occurring during the period over which the samples are composited.

**f. Bacterial Standards and Analysis**

- i. The geometric mean used for determining compliance with bacterial standards is calculated with the following equation:

$$\text{Geometric Mean} = (C_1 \times C_2 \times \dots \times C_n)^{1/n}$$

Where n is the number of days samples were collected during the period and C is the concentration of bacteria (CFU/100 mL) found on each day of sampling.

- ii. For all bacterial analyses, sample dilutions should be performed so the range of values extends from 2 to 16,000 CFU (colony-forming units). The detection methods used for each analysis shall be reported with the results of the analysis. Detection methods used for coliforms (total and fecal) shall be those listed in 40 CFR 136 or any improved method determined by the Regional Water Board (and approved by USEPA) to be appropriate. Detection methods used for enterococcus shall be those presented in USEPA publication USEPA 600/4-85/076, *Test Methods for Escherichia coli and Enterococci in Water by Membrane Filter Procedure*, listed under 40 CFR 136, and any other method approved by the Regional Water Board.

**g. Single Operational Upset**

A single operational upset (SOU) that leads to simultaneous violations or more than one pollutant parameter shall be treated as a single violation and limits the Discharger's liability in accordance with the following conditions:

- i. A single operational upset is broadly defined as a single unusual event that temporarily disrupts the usually satisfactory operation of a system in such a way that it results in violation of multiple pollutant parameters.
- ii. A Discharger may assert SOU to limit liability only for those violations which the Discharger submitted notice of the upset as required in Provision H of Attachment D.
- iii. For purposes outside of CWC section 13385(h) and (i), determination of compliance and civil liability (including any more specific definition of SOU), the requirements for Dischargers to assert the SOU limitation of liability, and the manner of counting violations, shall be in accordance with the USEPA Memorandum "Issuance of Guidance Interpreting Single Operational Upset" (September 27, 1989).

- iv.** For purposes of CWC section 13385(h) and (i), determination of compliance and civil liability (including any more specific definition of SOU, the requirements for Dischargers to assert the SOU limitation of liability, and the manner of counting violations shall be in accordance with CWC section 13385(f)(2).

## ATTACHMENT A – DEFINITIONS

### Acute Toxicity

a. Acute Toxicity (TUa)

Expressed in Toxic Units Acute (TUa)

$$TUa = \frac{100}{\frac{96\text{-hr LC}}{50\%}}$$

b. Lethal Concentration 50% (LC 50)

LC 50 (percent waste giving 50% survival of test organisms) shall be determined by static or continuous flow bioassay techniques using standard marine test species as specified in Ocean Plan Appendix III. If specific identifiable substances in wastewater can be demonstrated by the discharger as being rapidly rendered harmless upon discharge to the marine environment, but not as a result of dilution, the LC 50 may be determined after the test samples are adjusted to remove the influence of those substances.

When it is not possible to measure the 96-hour LC 50 due to greater than 50 percent survival of the test species in 100 percent waste, the toxicity concentration shall be calculated by the expression:

$$TUa = \frac{\log(100 - S)}{1.7}$$

where:

S = percentage survival in 100% waste. If S > 99, TUa shall be reported as zero.

### Areas of Special Biological Significance (ASBS)

Those areas designated by the State Water Board as ocean areas requiring protection of species or biological communities to the extent that alteration of natural water quality is undesirable. All Areas of Special Biological Significance are also classified as a subset of STATE WATER QUALITY PROTECTION AREAS.

### Average Monthly Effluent Limitation (AMEL)

The highest allowable average of daily discharges over a calendar month, calculated as the sum of all daily discharges measured during a calendar month divided by the number of daily discharges measured during that month.

### Average Weekly Effluent Limitation (AWEL)

The highest allowable average of daily discharges over a calendar week (Sunday through Saturday), calculated as the sum of all daily discharges measured during a calendar week divided by the number of daily discharges measured during that week.

### **Best Management Practices (BMPs)**

Schedules of activities, prohibitions of practices, maintenance procedures, and other management practices to prevent or reduce the pollution of waters of the United States. BMPs also include treatment requirements, operating procedures, and practices to control plant site runoff, spillage or leaks, sludge or waste disposal, or drainage from raw material storage.

### **Best Professional Judgment (BPJ)**

The method used by permit writers to develop technology-based NPDES permit conditions on a case-by-case basis using all reasonably available and relevant data.

### **Bioaccumulative Pollutants**

Those substances taken up by an organism from its surrounding medium through gill membranes, epithelial tissue, or from food and subsequently concentrated and retained in the body of the organism.

### **Chlordane**

Shall mean the sum of chlordane-alpha, chlordane-gamma, chlordene-alpha, chlordene-gamma, nonachlor-alpha, nonachlor-gamma, and oxychlordane.

### **Chronic Toxicity**

This parameter shall be used to measure the acceptability of waters for supporting a healthy marine biota until improved methods are developed to evaluate biological response.

#### a. Chronic Toxicity (TUc)

Expressed as Toxic Units Chronic (TUc)

$$TUc = \frac{100}{NOEL}$$

#### b. No Observed Effect Level (NOEL)

The NOEL is expressed as the maximum percent effluent or receiving water that causes no observable effect on a test organism, as determined by the result of a critical life stage toxicity test listed in Ocean Plan Appendix II.

### **Daily Discharge**

Daily Discharge is defined as either: (1) the total mass of the constituent discharged over the calendar day (12:00 am through 11:59 pm) or any 24-hour period that reasonably represents a calendar day for purposes of sampling (as specified in the permit), for a constituent with limitations expressed in units of mass or; (2) the unweighted arithmetic mean measurement of the constituent over the day for a constituent with limitations expressed in other units of measurement (e.g., concentration).

The daily discharge may be determined by the analytical results of a composite sample taken over the course of one day (a calendar day or other 24-hour period defined as a day) or by the

arithmetic mean of analytical results from one or more grab samples taken over the course of the day.

For composite sampling, if 1 day is defined as a 24-hour period other than a calendar day, the analytical result for the 24-hour period will be considered as the result for the calendar day in which the 24-hour period ends.

### **DDT**

Shall mean the sum of 4,4'DDT, 2,4'DDT, 4,4'DDE, 2,4'DDE, 4,4'DDD, and 2,4'DDD.

### **Degrade**

Degradation shall be determined by comparison of the waste field and reference site(s) for characteristic species diversity, population density, contamination, growth anomalies, debility, or supplanting of normal species by undesirable plant and animal species. Degradation occurs if there are significant differences in any of three major biotic groups, namely, demersal fish, benthic invertebrates, or attached algae. Other groups may be evaluated where benthic species are not affected, or are not the only ones affected.

### **Detected, but Not Quantified (DNQ)**

Sample results that are less than the reported Minimum Level, but greater than or equal to the laboratory's MDL.

### **Dichlorobenzenes**

Shall mean the sum of 1,2- and 1,3-dichlorobenzene.

### **Downstream Ocean Waters**

Waters downstream with respect to ocean currents.

### **Dredged Material**

Any material excavated or dredged from the navigable waters of the United States, including material otherwise referred to as "spoil".

### **Enclosed Bays**

Indentations along the coast that enclose an area of oceanic water within distinct headlands or harbor works. Enclosed bays include all bays where the narrowest distance between headlands or outermost harbor works is less than 75 percent of the greatest dimension of the enclosed portion of the bay. This definition includes but is not limited to: Humboldt Bay, Bodega Harbor, Tomales Bay, Drakes Estero, San Francisco Bay, Morro Bay, Los Angeles Harbor, Upper and Lower Newport Bay, Mission Bay, and San Diego Bay.

### **Endosulfan**

The sum of endosulfan-alpha and -beta and endosulfan sulfate.

**Estuaries and Coastal Lagoons** are waters at the mouths of streams that serve as mixing zones for fresh and ocean waters during a major portion of the year. Mouths of streams that are temporarily separated from the ocean by sandbars shall be considered as estuaries. Estuarine waters will generally be considered to extend from a bay or the open ocean to the upstream limit of tidal action but may be considered to extend seaward if significant mixing of

fresh and salt water occurs in the open coastal waters. The waters described by this definition include but are not limited to the Sacramento-San Joaquin Delta as defined by Section 12220 of the California Water Code, Suisun Bay, Carquinez Strait downstream to Carquinez Bridge, and appropriate areas of the Smith, Klamath, Mad, Eel, Noyo, and Russian Rivers.

**Halomethanes** shall mean the sum of bromoform, bromomethane (methyl bromide) and chloromethane (methyl chloride).

**HCH** shall mean the sum of the alpha, beta, gamma (Lindane) and delta isomers of hexachlorocyclohexane.

### **Initial Dilution**

The process that results in the rapid and irreversible turbulent mixing of wastewater with ocean water around the point of discharge.

For a submerged buoyant discharge, characteristic of most municipal and industrial wastes that are released from the submarine outfalls, the momentum of the discharge and its initial buoyancy act together to produce turbulent mixing. Initial dilution in this case is completed when the diluting wastewater ceases to rise in the water column and first begins to spread horizontally.

For shallow water submerged discharges, surface discharges, and non-buoyant discharges, characteristic of cooling water wastes and some individual discharges, turbulent mixing results primarily from the momentum of discharge. Initial dilution, in these cases, is considered to be completed when the momentum induced velocity of the discharge ceases to produce significant mixing of the waste, or the diluting plume reaches a fixed distance from the discharge to be specified by the Regional Water Board, whichever results in the lower estimate for initial dilution.

### **Instantaneous Maximum Effluent Limitation**

The highest allowable value for any single grab sample or aliquot (i.e., each grab sample or aliquot is independently compared to the instantaneous maximum limitation).

### **Instantaneous Minimum Effluent Limitation**

The lowest allowable value for any single grab sample or aliquot (i.e., each grab sample or aliquot is independently compared to the instantaneous minimum limitation).

### **Kelp Beds**

For purposes of the bacteriological standards of the Ocean Plan, are significant aggregations of marine algae of the genera Macrocystis and Nereocystis. Kelp beds include the total foliage canopy of Macrocystis and Nereocystis plants throughout the water column.

### **Mariculture**

The culture of plants and animals in marine waters independent of any pollution source.

### **Material**

(a) In common usage: (1) the substance or substances of which a thing is made or composed (2) substantial; (b) For purposes of the Ocean Plan relating to waste disposal, dredging and



the disposal of dredged material and fill, MATERIAL means matter of any kind or description which is subject to regulation as waste, or any material dredged from the navigable waters of the United States. See also, DREDGED MATERIAL.

**Maximum Daily Effluent Limitation (MDEL)**

The highest allowable daily discharge of a pollutant.

**Method Detection Limit (MDL)**

The minimum concentration of a substance that can be measured and reported with 99 percent confidence that the analyte concentration is greater than zero, as defined in title 40 of the Code of Federal Regulations, Part 136, Attachment B.

**Minimum Level (ML)**

The concentration at which the entire analytical system must give a recognizable signal and acceptable calibration point. The ML is the concentration in a sample that is equivalent to the concentration of the lowest calibration standard analyzed by a specific analytical procedure, assuming that all the method specified sample weights, volumes, and processing steps have been followed.

**Natural Light**

Reduction of natural light may be determined by the Regional Water Board by measurement of light transmissivity or total irradiance, or both, according to the monitoring needs of the Regional Water Board.

**Not Detected (ND)**

Those sample results less than the laboratory's MDL.

**Nuisance**

California Water Code section 13050, subdivision (m), defines nuisance as anything which meets all of the following requirements:

1. Is injurious to health, or is indecent or offensive to the senses, or an obstruction to the free use of property, so as to interfere with the comfortable enjoyment of life or property.
2. Affects at the same time an entire community or neighborhood, or any considerable number of persons, although the extent of the annoyance or damage inflicted upon individuals may be unequal.
3. Occurs during, or as a result of, the treatment or disposal of wastes.

**Ocean Waters**

The territorial marine waters of the State as defined by California law to the extent these waters are outside of enclosed bays, estuaries, and coastal lagoons. If a discharge outside the territorial waters of the State could affect the quality of the waters of the State, the discharge may be regulated to assure no violation of the Ocean Plan will occur in ocean waters.

### **PAHs (polynuclear aromatic hydrocarbons)**

The sum of acenaphthylene, anthracene, 1,2-benzanthracene, 3,4-benzofluoranthene, benzo[k]fluoranthene, 1,12-benzoperylene, benzo[a]pyrene, chrysene, dibenzo[ah]anthracene, fluorene, indeno[1,2,3-cd]pyrene, phenanthrene and pyrene.

### **PCBs (polychlorinated biphenyls)**

The sum of chlorinated biphenyls whose analytical characteristics resemble those of Aroclor-1016, Aroclor-1221, Aroclor-1232, Aroclor-1242, Aroclor-1248, Aroclor-1254 and Aroclor-1260.

### **Pollutant Minimization Program (PMP)**

PMP means waste minimization and pollution prevention actions that include, but are not limited to, product substitution, waste stream recycling, alternative waste management methods, and education of the public and businesses. The goal of the PMP shall be to reduce all potential sources of Ocean Plan Table B pollutants through pollutant minimization (control) strategies, including pollution prevention measures as appropriate, to maintain the effluent concentration at or below the water quality-based effluent limitation. Pollution prevention measures may be particularly appropriate for persistent bioaccumulative priority pollutants where there is evidence that beneficial uses are being impacted. The Regional Water Board may consider cost effectiveness when establishing the requirements of a PMP. The completion and implementation of a Pollution Prevention Plan, if required pursuant to Water Code section 13263.3(d), shall be considered to fulfill the PMP requirements.

### **Reported Minimum Level**

The ML (and its associated analytical method) chosen by the Discharger for reporting and compliance determination from the MLs included in this Order. The MLs included in this Order correspond to approved analytical methods for reporting a sample result that are selected by the Regional Water Board either from Appendix II of the Ocean Plan in accordance with section III.C.5.a. of the Ocean Plan or established in accordance with section III.C.5.b. of the Ocean Plan. The ML is based on the proper application of method-based analytical procedures for sample preparation and the absence of any matrix interferences. Other factors may be applied to the ML depending on the specific sample preparation steps employed. For example, the treatment typically applied in cases where there are matrix-effects is to dilute the sample or sample aliquot by a factor of ten. In such cases, this additional factor must be applied to the ML in the computation of the reported ML.

### **Sanitary Sewer Overflow (SSO)**

Any overflow, spill, release, discharge or diversion of untreated or partially treated wastewater from a sanitary sewer system. SSOs include:

1. Overflows or releases of untreated or partially treated wastewater that reach waters of the United States;
2. Overflows or releases of untreated or partially treated wastewater that do not reach waters of the United States; and
3. Wastewater backups into buildings and on private property that are caused by blockages or flow conditions within the publicly owned portion of a sanitary sewer system.

## SSO Categories

1. **Category 1** - All discharges of sewage resulting from a failure in the Discharger's sanitary sewer system that:
  - A. Equal or exceed 1000 gallons, or
  - B. Result in a discharge to a drainage channel and/or surface water; or
  - C. Discharge to a storm drainpipe that was not fully captured and returned to the sanitary sewer system.
2. **Category 2** – All other discharges of sewage resulting from a failure in the Discharger's sanitary sewer system.
3. **Private Lateral Sewage Discharges** – Sewage discharges that are caused by blockages or other problems within a privately owned lateral.

### Sanitary Sewer System

Any system of pipes, pump stations, sewer lines, or other conveyances, upstream of a wastewater treatment plant headworks used to collect and convey wastewater to the wastewater treatment facility. Temporary storage and conveyance facilities (such as vaults, temporary piping, construction trenches, wet wells, impoundments, tanks, etc.) are considered to be part of the sanitary sewer system, and discharges into these temporary storage facilities are not considered to be SSOs

### Satellite Collection System

The portion, if any, of a sanitary sewer system owned or operated by a different public agency than the agency that owns and operates the wastewater treatment facility that a sanitary sewer system is tributary to.

### Shellfish

Organisms identified by the California Department of Health Services as shellfish for public health purposes (i.e., mussels, clams and oysters).

### Significant Difference

Defined as a statistically significant difference in the means of two distributions of sampling results at the 95 percent confidence level.

### Six-month Median Effluent Limitation

The highest allowable moving median of all daily discharges for any 180-day period.

### SSO Reporting System

Online spill reporting system that is hosted, controlled, and maintained by the State Water Board. The web address for this site is <http://ciwqs.waterboards.ca.gov>. This online database is maintained on a secure site and is controlled by unique usernames and passwords.

**State Water Quality Protection Areas (SWQPAs)**

Non-terrestrial marine or estuarine areas designated to protect marine species or biological communities from an undesirable alteration in natural water quality. All AREAS OF SPECIAL BIOLOGICAL SIGNIFICANCE (ASBS) that were previously designated by the State Water Board in Resolution Nos. 74-28, 74-32, and 75-61 are now also classified as a subset of State Water Quality Protection Areas and require special protections afforded by the Ocean Plan.

**TCDD Equivalents**

The sum of the concentrations of chlorinated dibenzodioxins (2,3,7,8-CDDs) and chlorinated dibenzofurans (2,3,7,8-CDFs) multiplied by their respective toxicity factors, as shown in the table below.

Isomer Group	Toxicity Equivalence Factor
2,3,7,8-tetra CDD	1.0
2,3,7,8-penta CDD	0.5
2,3,7,8-hexa CDDs	0.1
2,3,7,8-hepta CDD	0.01
octa CDD	0.001
2,3,7,8 tetra CDF	0.1
1,2,3,7,8 penta CDF	0.05
2,3,4,7,8 penta CDF	0.5
2,3,7,8 hexa CDFs	0.1
2,3,7,8 hepta CDFs	0.01
octa CDF	0.001

**Toxicity Reduction Evaluation (TRE)**

A study conducted in a step-wise process designed to identify the causative agents of effluent or ambient toxicity, isolate the sources of toxicity, evaluate the effectiveness of toxicity control options, and then confirm the reduction in toxicity. The first steps of the TRE consist of the collection of data relevant to the toxicity, including additional toxicity testing, and an evaluation of facility operations and maintenance practices, and best management practices. A Toxicity Identification Evaluation (TIE) may be required as part of the TRE, if appropriate. (A TIE is a set of procedures to identify the specific chemical(s) responsible for toxicity. These procedures are performed in three phases (characterization, identification, and confirmation) using aquatic organism toxicity tests).

**Untreated or Partially Treated Wastewater**

Any volume of waste discharged from the sanitary sewer system upstream of a wastewater treatment plant headworks.

**Waste**

As used in the Ocean Plan, waste includes a Discharger’s total discharge, of whatever origin (i.e., gross, not net, discharge).

**Water Reclamation**

The treatment of wastewater to render it suitable for reuse, the transportation of treated wastewater to the place of use, and the actual use of treated wastewater for a direct beneficial use or controlled use that would not otherwise occur.

**ATTACHMENT B – MAP**

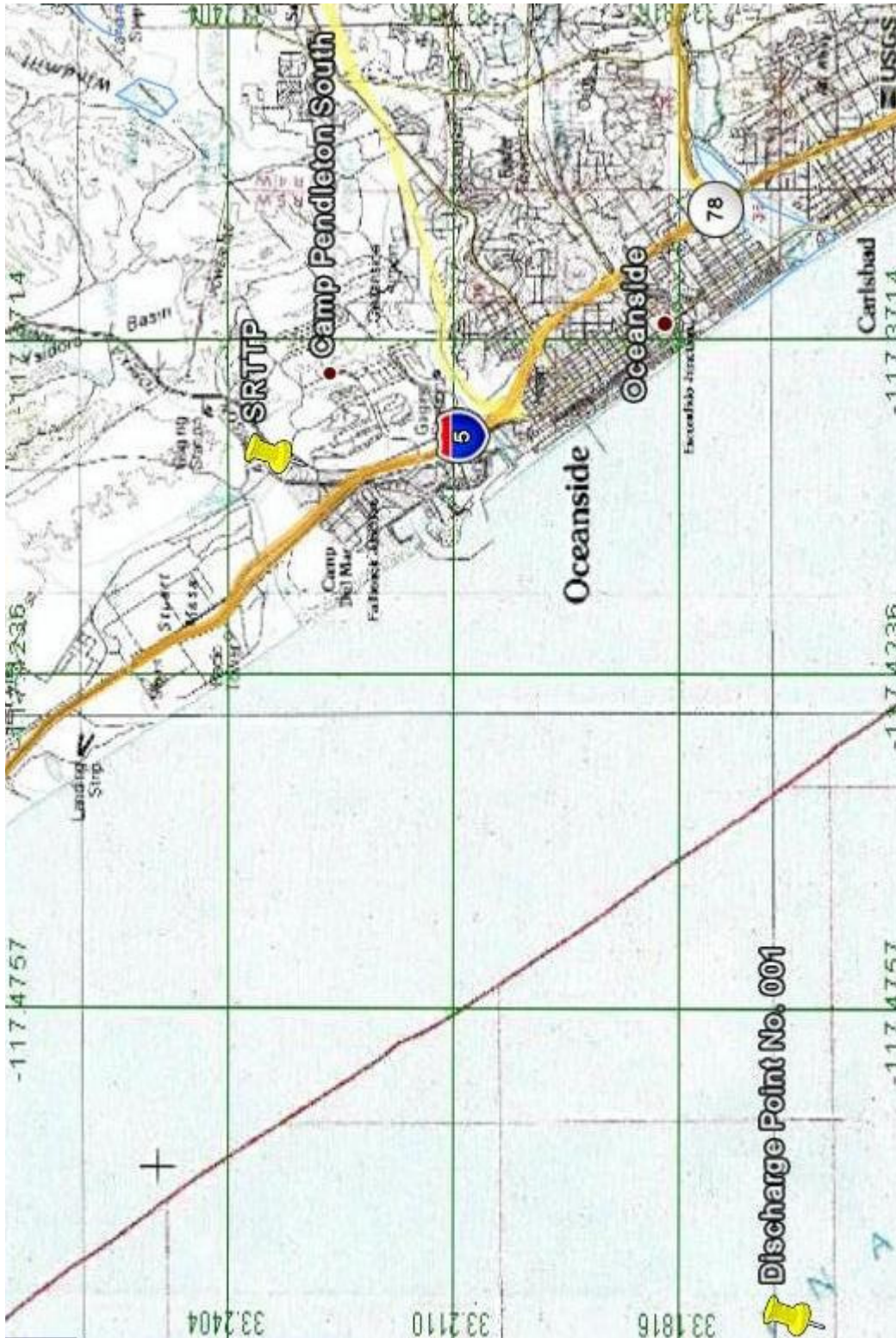

**ATTACHMENT C – FLOW SCHEMATIC**

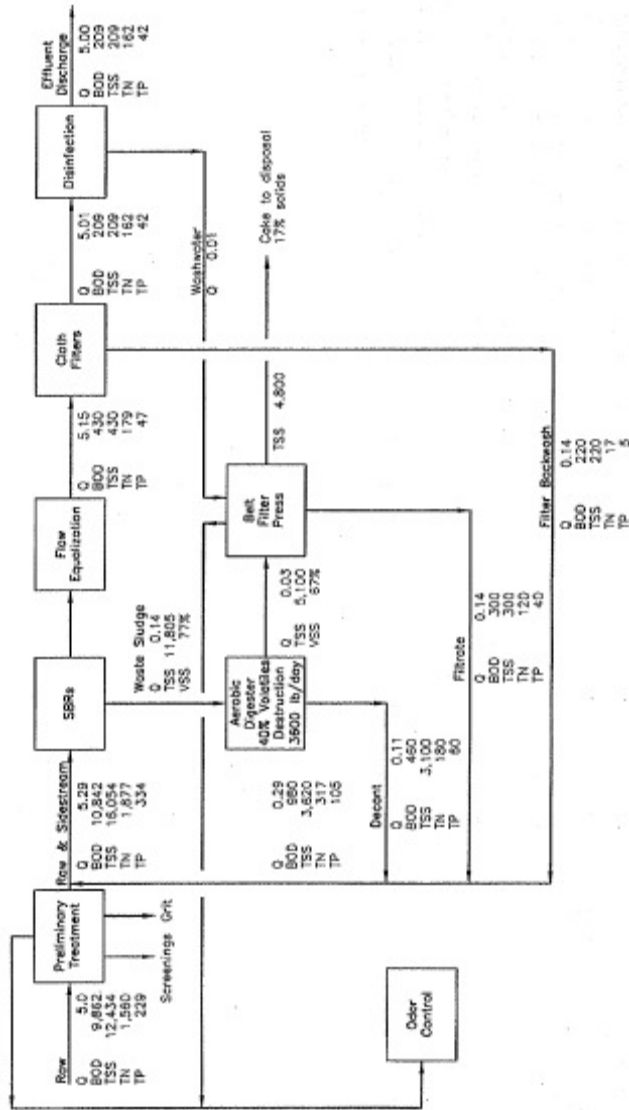

Note: Average Load Mass Balance reported in pounds per day

CDM

Figure 2C-1  
Average Load Mass Balance of Camp Pendleton Southern  
Region Tertiary Treatment Plant at Full Capacity

## **ATTACHMENT D – STANDARD PROVISIONS**

### **I. STANDARD PROVISIONS – PERMIT COMPLIANCE**

#### **A. Duty to Comply**

3. The Discharger must comply with all of the conditions of this Order. Any noncompliance constitutes a violation of the Clean Water Act (CWA) and the California Water Code and is grounds for enforcement action, for permit termination, revocation and reissuance, or modification; or denial of a permit renewal application. (40 CFR § 122.41(a))
4. The Discharger shall comply with effluent standards or prohibitions established under Section 307(a) of the CWA for toxic pollutants and with standards for sewage sludge use or disposal established under Section 405(d) of the CWA within the time provided in the regulations that establish these standards or prohibitions, even if this Order has not yet been modified to incorporate the requirement. (40 CFR § 122.41(a)(1))

#### **B. Need to Halt or Reduce Activity Not a Defense**

It shall not be a defense for a Discharger in an enforcement action that it would have been necessary to halt or reduce the permitted activity in order to maintain compliance with the conditions of this Order. (40 CFR § 122.41(c))

#### **C. Duty to Mitigate**

The Discharger shall take all reasonable steps to minimize or prevent any discharge or sludge use or disposal in violation of this Order that has a reasonable likelihood of adversely affecting human health or the environment. (40 CFR § 122.41(d))

#### **D. Proper Operation and Maintenance**

The Discharger shall at all times properly operate and maintain all facilities and systems of treatment and control (and related appurtenances) which are installed or used by the Discharger to achieve compliance with the conditions of this Order. Proper operation and maintenance also includes adequate laboratory controls and appropriate quality assurance procedures. This provision requires the operation of backup or auxiliary facilities or similar systems that are installed by a Discharger only when necessary to achieve compliance with the conditions of this Order. (40 CFR § 122.41(e))

#### **E. Property Rights**

1. This Order does not convey any property rights of any sort or any exclusive privileges. (40 CFR § 122.41(g))



2. The issuance of this Order does not authorize any injury to persons or property or invasion of other private rights, or any infringement of State or local law or regulations. (40 CFR § 122.5(c))

## **F. Inspection and Entry**

The Discharger shall allow the Regional Water Board, State Water Board, United States Environmental Protection Agency (USEPA), and/or their authorized representatives (including an authorized contractor acting as their representative), upon the presentation of credentials and other documents, as may be required by law, to (40 CFR § 122.41(i); Water Code, § 13383):

1. Enter upon the Discharger's premises where a regulated facility or activity is located or conducted, or where records are kept under the conditions of this Order (40 CFR § 122.41(i)(1));
2. Have access to and copy, at reasonable times, any records that must be kept under the conditions of this Order (40 CFR § 122.41(i)(2));
3. Inspect and photograph, at reasonable times, any facilities, equipment (including monitoring and control equipment), practices, or operations regulated or required under this Order (40 CFR § 122.41(i)(3)); and
4. Sample or monitor, at reasonable times, for the purposes of assuring Order compliance or as otherwise authorized by the CWA or the Water Code, any substances or parameters at any location. (40 CFR § 122.41(i)(4))

## **G. Bypass**

1. Definitions
  - a. "Bypass" means the intentional diversion of waste streams from any portion of a treatment facility. (40 CFR § 122.41(m)(1)(i))
  - b. "Severe property damage" means substantial physical damage to property, damage to the treatment facilities, which causes them to become inoperable, or substantial and permanent loss of natural resources that can reasonably be expected to occur in the absence of a bypass. Severe property damage does not mean economic loss caused by delays in production. (40 CFR § 122.41(m)(1)(ii))
2. Bypass not exceeding limitations. The Discharger may allow any bypass to occur which does not cause exceedances of effluent limitations, but only if it is for essential maintenance to assure efficient operation. These bypasses are not subject to the provisions listed in Standard Provisions – Permit Compliance I.G.3, I.G.4, and I.G.5 below. (40 CFR § 122.41(m)(2))

3. Prohibition of bypass. Bypass is prohibited, and the Regional Water Board may take enforcement action against a Discharger for bypass, unless (40 CFR § 122.41(m)(4)(i)):
  - a. Bypass was unavoidable to prevent loss of life, personal injury, or severe property damage (40 CFR § 122.41(m)(4)(i)(A));
  - b. There were no feasible alternatives to the bypass, such as the use of auxiliary treatment facilities, retention of untreated wastes, or maintenance during normal periods of equipment downtime. This condition is not satisfied if adequate back-up equipment should have been installed in the exercise of reasonable engineering judgment to prevent a bypass that occurred during normal periods of equipment downtime or preventive maintenance (40 CFR § 122.41(m)(4)(i)(B)); and
  - c. The Discharger submitted notice to the Regional Water Board as required under Standard Provisions – Permit Compliance I.G.5 below. (40 CFR § 122.41(m)(4)(i)(C))
4. The Regional Water Board may approve an anticipated bypass, after considering its adverse effects, if the Regional Water Board determines that it will meet the three conditions listed in Standard Provisions – Permit Compliance I.G.3 above. (40 CFR § 122.41(m)(4)(ii))
5. **Notice**
  - a. Anticipated bypass. If the Discharger knows in advance of the need for a bypass, it shall submit a notice, if possible at least 10 days before the date of the bypass. (40 CFR § 122.41(m)(3)(i))
  - b. Unanticipated bypass. The Discharger shall submit notice of an unanticipated bypass as required in Standard Provisions - Reporting V.E below (24-hour notice). (40 CFR § 122.41(m)(3)(ii))

## H. Upset

Upset means an exceptional incident in which there is unintentional and temporary noncompliance with technology based permit effluent limitations because of factors beyond the reasonable control of the Discharger. An upset does not include noncompliance to the extent caused by operational error, improperly designed treatment facilities, inadequate treatment facilities, lack of preventive maintenance, or careless or improper operation. (40 CFR § 122.41(n)(1))

1. Effect of an upset. An upset constitutes an affirmative defense to an action brought for noncompliance with such technology based permit effluent limitations if the requirements of Standard Provisions – Permit Compliance I.H.2 below are met. No determination made during administrative review of claims that noncompliance was

caused by upset, and before an action for noncompliance, is final administrative action subject to judicial review. (40 CFR § 122.41(n)(2))

2. Conditions necessary for a demonstration of upset. A Discharger who wishes to establish the affirmative defense of upset shall demonstrate, through properly signed, contemporaneous operating logs or other relevant evidence that (40 CFR § 122.41(n)(3)):
  - a. An upset occurred and that the Discharger can identify the cause(s) of the upset (40 CFR § 122.41(n)(3)(i));
  - b. The permitted facility was, at the time, being properly operated (40 CFR § 122.41(n)(3)(ii));
  - c. The Discharger submitted notice of the upset as required in Standard Provisions – Reporting V.E.2.b below (24-hour notice) (40 CFR § 122.41(n)(3)(iii)); and
  - d. The Discharger complied with any remedial measures required under Standard Provisions – Permit Compliance I.C above. (40 CFR § 122.41(n)(3)(iv))
3. Burden of proof. In any enforcement proceeding, the Discharger seeking to establish the occurrence of an upset has the burden of proof. (40 CFR § 122.41(n)(4))

## **II. STANDARD PROVISIONS – PERMIT ACTION**

### **A. General**

This Order may be modified, revoked and reissued, or terminated for cause. The filing of a request by the Discharger for modification, revocation and reissuance, or termination, or a notification of planned changes or anticipated noncompliance does not stay any Order condition. (40 CFR § 122.41(f))

### **B. Duty to Reapply**

If the Discharger wishes to continue an activity regulated by this Order after the expiration date of this Order, the Discharger must apply for and obtain a new permit. (40 CFR § 122.41(b))

### **C. Transfers**

This Order is not transferable to any person except after notice to the Regional Water Board. The Regional Water Board may require modification or revocation and reissuance of the Order to change the name of the Discharger and incorporate such other requirements as may be necessary under the CWA and the Water Code. (40 CFR § 122.41(l)(3); § 122.61)

### **III. STANDARD PROVISIONS – MONITORING**

- A. Samples and measurements taken for the purpose of monitoring shall be representative of the monitored activity. (40 CFR § 122.41(j)(1))
- B. Monitoring results must be conducted according to test procedures under Part 136 or, in the case of sludge use or disposal, approved under Part 136 unless otherwise specified in Part 503 unless other test procedures have been specified in this Order. (40 CFR § 122.41(j)(4); § 122.44(i)(1)(iv))

### **IV. STANDARD PROVISIONS – RECORDS**

- A. Except for records of monitoring information required by this Order related to the Discharger's sewage sludge use and disposal activities, which shall be retained for a period of at least five years (or longer as required by Part 503), the Discharger shall retain records of all monitoring information, including all calibration and maintenance records and all original strip chart recordings for continuous monitoring instrumentation, copies of all reports required by this Order, and records of all data used to complete the application for this Order, for a period of at least three (3) years from the date of the sample, measurement, report or application. This period may be extended by request of the Regional Water Board Executive Officer at any time. (40 CFR § 122.41(j)(2))

#### **B. Records of monitoring information shall include:**

- 1. The date, exact place, and time of sampling or measurements (40 CFR § 122.41(j)(3)(i));
- 2. The individual(s) who performed the sampling or measurements (40 CFR § 122.41(j)(3)(ii));
- 3. The date(s) analyses were performed (40 CFR § 122.41(j)(3)(iii));
- 4. The individual(s) who performed the analyses (40 CFR § 122.41(j)(3)(iv));
- 5. The analytical techniques or methods used (40 CFR § 122.41(j)(3)(v)); and
- 6. The results of such analyses. (40 CFR § 122.41(j)(3)(vi))

#### **C. Claims of confidentiality for the following information will be denied (40 CFR § 122.7(b)):**

- 1. The name and address of any permit applicant or Discharger (40 CFR § 122.7(b)(1)); and
- 2. Permit applications and attachments, permits and effluent data. (40 CFR § 122.7(b)(2))

## **V. STANDARD PROVISIONS – REPORTING**

### **A. Duty to Provide Information**

The Discharger shall furnish to the Regional Water Board, State Water Board, or USEPA within a reasonable time, any information which the Regional Water Board, State Water Board, or USEPA may request to determine whether cause exists for modifying, revoking and reissuing, or terminating this Order or to determine compliance with this Order. Upon request, the Discharger shall also furnish to the Regional Water Board, State Water Board, or USEPA copies of records required to be kept by this Order. (40 CFR § 122.41(h); Water Code, § 13267)

### **B. Signatory and Certification Requirements**

1. All applications, reports, or information submitted to the Regional Water Board, State Water Board, and/or USEPA shall be signed and certified in accordance with Standard Provisions – Reporting V.B.2, V.B.3, V.B.4, and V.B.5 below. (40 CFR § 122.41(k))
2. All permit applications shall be signed by either a principal executive officer or ranking elected official. For purposes of this provision, a principal executive officer of a federal agency includes: (i) the chief executive officer of the agency, or (ii) a senior executive officer having responsibility for the overall operations of a principal geographic unit of the agency (e.g., Regional Administrators of USEPA). (40 CFR § 122.22(a)(3)).
3. All reports required by this Order and other information requested by the Regional Water Board, State Water Board, or USEPA shall be signed by a person described in Standard Provisions – Reporting V.B.2 above, or by a duly authorized representative of that person. A person is a duly authorized representative only if:
  - a. The authorization is made in writing by a person described in Standard Provisions – Reporting V.B.2 above (40 CFR § 122.22(b)(1));
  - b. The authorization specifies either an individual or a position having responsibility for the overall operation of the regulated facility or activity such as the position of plant manager, operator of a well or a well field, superintendent, position of equivalent responsibility, or an individual or position having overall responsibility for environmental matters for the company. (A duly authorized representative may thus be either a named individual or any individual occupying a named position.) (40 CFR § 122.22(b)(2)); and
  - c. The written authorization is submitted to the Regional Water Board and State Water Board. (40 CFR § 122.22(b)(3))
4. If an authorization under Standard Provisions – Reporting V.B.3 above is no longer accurate because a different individual or position has responsibility for the overall operation of the facility, a new authorization satisfying the requirements of Standard

Provisions – Reporting V.B.3 above must be submitted to the Regional Water Board and State Water Board prior to or together with any reports, information, or applications, to be signed by an authorized representative. (40 CFR § 122.22(c))

5. Any person signing a document under Standard Provisions – Reporting V.B.2 or V.B.3 above shall make the following certification:

“I certify under penalty of law that this document and all attachments were prepared under my direction or supervision in accordance with a system designed to assure that qualified personnel properly gather and evaluate the information submitted. Based on my inquiry of the person or persons who manage the system or those persons directly responsible for gathering the information, the information submitted is, to the best of my knowledge and belief, true, accurate, and complete. I am aware that there are significant penalties for submitting false information, including the possibility of fine and imprisonment for knowing violations.” (40 CFR § 122.22(d))

### **C. Monitoring Reports**

1. Monitoring results shall be reported at the intervals specified in the Monitoring and Reporting Program (Attachment E) in this Order. (40 CFR § 122.22(l)(4))
2. Monitoring results must be reported on a Discharge Monitoring Report (DMR) form or forms provided or specified by the Regional Water Board or State Water Board for reporting results of monitoring of sludge use or disposal practices. (40 CFR § 122.41(l)(4)(i))
3. If the Discharger monitors any pollutant more frequently than required by this Order using test procedures approved under Part 136 or, in the case of sludge use or disposal, approved under Part 136 unless otherwise specified in Part 503, or as specified in this Order, the results of this monitoring shall be included in the calculation and reporting of the data submitted in the DMR or sludge reporting form specified by the Regional Water Board. (40 CFR § 122.41(l)(4)(ii))
4. Calculations for all limitations, which require averaging of measurements, shall utilize an arithmetic mean unless otherwise specified in this Order. (40 CFR § 122.41(l)(4)(iii))

### **D. Compliance Schedules**

Reports of compliance or noncompliance with, or any progress reports on, interim and final requirements contained in any compliance schedule of this Order, shall be submitted no later than 14 days following each schedule date. (40 CFR § 122.41(l)(5))

### **E. Twenty Four-Hour Reporting**

1. The Discharger shall report any noncompliance that may endanger health or the environment. Any information shall be provided orally within 24 hours from the time the Discharger becomes aware of the circumstances. A written submission shall

also be provided within five (5) days of the time the Discharger becomes aware of the circumstances. The written submission shall contain a description of the noncompliance and its cause; the period of noncompliance, including exact dates and times, and if the noncompliance has not been corrected, the anticipated time it is expected to continue; and steps taken or planned to reduce, eliminate, and prevent reoccurrence of the noncompliance. (40 CFR § 122.41(l)(6)(i))

2. The following shall be included as information that must be reported within 24 hours under this paragraph (40 CFR § 122.41(l)(6)(ii)):
  - a. Any unanticipated bypass that exceeds any effluent limitation in this Order. (40 CFR § 122.41(l)(6)(ii)(A))
  - b. Any upset that exceeds any effluent limitation in this Order. (40 CFR § 122.41(l)(6)(ii)(B))
3. The Regional Water Board may waive the above-required written report under this provision on a case-by-case basis if an oral report has been received within 24 hours. (40 CFR § 122.41(l)(6)(iii))

#### **F. Planned Changes**

The Discharger shall give notice to the Regional Water Board as soon as possible of any planned physical alterations or additions to the permitted facility. Notice is required under this provision only when (40 CFR § 122.41(l)(1)):

1. The alteration or addition to a permitted facility may meet one of the criteria for determining whether a facility is a new source in section 122.29(b) (40 CFR § 122.41(l)(1)(i)); or
2. The alteration or addition could significantly change the nature or increase the quantity of pollutants discharged. This notification applies to pollutants that are not subject to effluent limitations in this Order. (40 CFR § 122.41(l)(1)(ii))
3. The alteration or addition results in a significant change in the Discharger's sludge use or disposal practices, and such alteration, addition, or change may justify the application of permit conditions that are different from or absent in the existing permit, including notification of additional use or disposal sites not reported during the permit application process or not reported pursuant to an approved land application plan. (40 CFR § 122.41(l)(1)(iii))

#### **G. Anticipated Noncompliance**

The Discharger shall give advance notice to the Regional Water Board or State Water Board of any planned changes in the permitted facility or activity that may result in noncompliance with General Order requirements. (40 CFR § 122.41(l)(2))

## **H. Other Noncompliance**

The Discharger shall report all instances of noncompliance not reported under Standard Provisions – Reporting V.C, V.D, and V.E above at the time monitoring reports are submitted. The reports shall contain the information listed in Standard Provision – Reporting V.E above. (40 CFR § 122.41(l)(7))

## **I. Other Information**

When the Discharger becomes aware that it failed to submit any relevant facts in a permit application, or submitted incorrect information in a permit application or in any report to the Regional Water Board, State Water Board, or USEPA, the Discharger shall promptly submit such facts or information. (40 CFR § 122.41(l)(8))

## **VI. STANDARD PROVISIONS – ENFORCEMENT**

- A. The Regional Water Board is authorized to enforce the terms of this permit under several provisions of the Water Code, including, but not limited to, sections 13385, 13386, and 13387

## **VII. ADDITIONAL PROVISIONS – NOTIFICATION LEVELS**

### **A. Publicly-Owned Treatment Works (POTWs)**

All POTWs shall provide adequate notice to the Regional Water Board of the following (40 CFR § 122.42(b)):

1. Any new introduction of pollutants into the POTW from an indirect discharger that would be subject to sections 301 or 306 of the CWA if it were directly discharging those pollutants (40 CFR § 122.42(b)(1)); and
2. Any substantial change in the volume or character of pollutants being introduced into that POTW by a source introducing pollutants into the POTW at the time of adoption of the Order. (40 CFR § 122.42(b)(2))
3. Adequate notice shall include information on the quality and quantity of effluent introduced into the POTW as well as any anticipated impact of the change on the quantity or quality of effluent to be discharged from the POTW. (40 CFR § 122.42(b)(3))



## ATTACHMENT E – MONITORING AND REPORTING PROGRAM

### Table of Contents

I.	General Monitoring Provisions.....	E-2
II.	Monitoring Locations .....	E-3
III.	Influent and emergency connection Monitoring Requirements .....	E-4
	A. Monitoring Location INF-001.....	E-4
IV.	Effluent Monitoring Requirements .....	E-4
	A. Monitoring Location EFF-001.....	E-4
V.	Whole Effluent Toxicity Testing Requirements .....	E-8
VI.	Land Discharge Monitoring Requirements – not applicable .....	E-9
VII.	Reclamation Monitoring Requirements – Not Applicable.....	E-9
VIII.	Receiving Water Monitoring Requirements – Surface Water.....	E-9
	A. Surf Zone Water Quality Monitoring.....	E-9
	B. Near Shore Water Quality Monitoring .....	E-10
	C. Off Shore Water Quality Monitoring .....	E-11
	D. Benthic Monitoring.....	E-12
	E. Additional Biological Monitoring .....	E-13
IX.	Other Monitoring Requirements.....	E-14
	A. Kelp Bed Canopy.....	E-14
	B. Regional Monitoring.....	E-14
	C. Solids Monitoring .....	E-14
	D. Sanitary Sewer Overflow .....	E-14
	E. General Monitoring and Reporting Requirements.....	E-17
	F. Self Monitoring Reports (SMRs) .....	E-18
	G. Discharge Monitoring Reports (DMRs) .....	E-21
	H. Other Reports .....	E-21

### List of Tables

Table E-1.	Monitoring Station Locations.....	E-3
Table E-2.	Influent Monitoring.....	E-4
Table E-3.	Effluent Monitoring .....	E-4
Table E-4.	Whole Effluent Toxicity Testing .....	E-8
Table E-5.	Approved Test for Chronic Toxicity .....	E-9
Table E-6.	Near Shore Water Quality Reduced Monitoring Requirements .....	E-10
Table E-7.	Near Shore Water Quality Reduced Monitoring Requirements .....	E-11
Table E-8.	Near Shore Water Quality Reduced Monitoring Requirements .. <b>Error! Bookmark not defined.</b>	
Table E-9.	Near Shore Water Quality Reduced Monitoring Requirements .....	E-11
Table E-10.	Sediment Monitoring Requirements .....	E-12
Table E-11.	Infauna Monitoring Requirements .....	E-12
Table E-12.	Demersal Fish and Macroinvertebrates Monitoring Requirements.....	E-13
Table E-13.	Monitoring Periods and Reporting Schedule .....	E-18

## **ATTACHMENT E – MONITORING AND REPORTING PROGRAM (MRP)**

The Code of Federal Regulations section 122.48 requires that all NPDES permits specify monitoring and reporting requirements. Water Code Sections 13267 and 13383 also authorize the Regional Water Quality Control Board (Regional Water Board) to require technical and monitoring reports. This MRP establishes monitoring and reporting requirements, which implement the federal and California regulations.

### **I. GENERAL MONITORING PROVISIONS**

- A.** Samples and measurements taken as required herein shall be representative of the volume and nature of the monitoring discharge. All samples shall be taken at the monitoring points specified below and, unless otherwise specified, before the monitored flow joins or is diluted by any other waste stream, body of water, or substance. Monitoring points shall not be changed without notification to and the approval of the Regional Water Board. Samples shall be collected at times representative of “worst case” conditions with respect to compliance with the requirement of Order No. R9-2008-0096.
- B.** Appropriate flow measurement devices and methods consistent with accepted scientific practices shall be selected and used to ensure the accuracy and reliability of measurements of the volume of monitored discharges. The devices shall be installed, calibrated and maintained to ensure that the accuracy of the measurement is consistent with the accepted capability of that type of device. Devices selected shall be capable of measuring flows with a maximum deviation of less than  $\pm 5$  percent from true discharge rates throughout the range of expected discharge volumes.
- C.** Monitoring must be conducted according to United States Environmental Protection Agency (USEPA) test procedures approved at 40 CFR Part 136, *Guidelines Establishing Test Procedures for the Analysis of Pollutants Under the Clean Water Act* as amended, or unless other test procedures are specified in Order No. R9-2008-0096 and/or in this MRP and/or by the Regional Water Board.
- D.** All analyses shall be performed in a laboratory certified to perform such analyses by the California Department of Public Health or a laboratory approved by the Regional Water Board.
- E.** Records of monitoring information shall include information required under Standard Provision, Attachment D, section IV.
- F.** All monitoring instruments and devices used by the Discharger to fulfill the prescribed monitoring program shall be properly maintained and calibrated as necessary to ensure their continued accuracy. All flow measurement devices shall be calibrated at least once per year, or more frequently, to ensure continued accuracy of the devices.
- G.** The Discharger shall have, and implement, an acceptable written quality assurance (QA) plan for laboratory analyses. Duplicate chemical analyses must be conducted on

a minimum of ten percent of the samples or at least one sample per month, whichever is greater. A similar frequency shall be maintained for analyzing spiked samples. When requested by USEPA or the Regional Water Board, the Discharger will participate in the NPDES discharge monitoring report QA performance study. The Discharger should have a success rate equal or greater than 80 percent.

- H. Analysis for toxic pollutants, including acute and chronic toxicity, with performance goals based on water quality objectives of the California Ocean Plan shall be conducted in accordance with procedures described in the California Ocean Plan and restated in this MRP.
- I. This permit may be modified in accordance with the requirements set forth at 40 CFR Parts 122 and 124, to include appropriate conditions or limits to address demonstrated effluent toxicity based on newly available information, or to implement any USEPA approved, new, State water quality standards applicable to effluent toxicity.

## II. MONITORING LOCATIONS

The Discharger shall establish the following monitoring locations to demonstrate compliance with the effluent limitations, discharge specifications, and other requirements in this Order:

**Table E-1. Monitoring Station Locations**

Discharge Point Name	Monitoring Location Name	Monitoring Location Description (include Latitude and Longitude when available)
--	INF-001	A location upstream of plant return streams, where a representative sample of the influent can be obtained
001	EFF-001	A location where a representative sample of the effluent can be obtained
<b>SURF ZONE STATIONS</b>		
--	S1	Surf zone, 5,500 feet south of the outfall
--	S2	Surf zone, 2,500 feet south of the outfall
--	S3	Surf zone, at the outfall (Latitude 33 09' 46"N; Longitude 117 23' 28"W)
--	S4	Surf zone, 2,000 feet north of the outfall
--	S5	Surf zone, 5,800 feet north of the outfall
<b>NEAR SHORE STATIONS</b>		
--	N1	Opposite S1, at the 30 foot depth contour, MLLW
--	N2	Opposite S2, at the 30 foot depth contour, MLLW
--	N3	Opposite S3, at the 30 foot depth contour, MLLW
--	N4	Opposite S4, at the 30 foot depth contour, MLLW
--	N5	Opposite S5, at the 30 foot depth contour, MLLW
<b>OFFSHORE STATIONS</b>		
--	A1 – A4	At the corners of a 1,000 ft. x 1,000 ft. square having one side parallel to shore and the intersection of its diagonals at the seaward end of the outfall
--	A5	At the intersection of its diagonals at the seaward end of the outfall
--	B1	One mile downcoast from the outfall, and over the same depth contour as Station A5
--	B2	One mile upcoast from the outfall, and over the same depth contour as Station A5

BIOLOGICAL TRANSECTS		
--	T0	At the 20, 40, 60, and 80 foot depth contours along the transect located 50 feet downcoast of and parallel to the outfall
--	T1	At the 20, 40, 60, and 80 foot depth contours along the transect located one mile downcoast of and parallel to the outfall
--	T2	At the 20, 40, 60, and 80 foot depth contours along the transect located one and one half miles upcoast of and parallel to the outfall

### III. INFLUENT AND EMERGENCY CONNECTION MONITORING REQUIREMENTS

#### A. Monitoring Location INF-001

1. The Discharger shall monitor influent at INF-001 as follows:

**Table E-2. Influent Monitoring**

Parameter	Units	Sample Type	Minimum Sampling Frequency	Required Analytical Test Method
Flow Rate	MGD	recorder/totalizer	continuous	1
Biochemical Oxygen Demand @ 20 °C (BOD <sub>5</sub> )	mg/L	24-hr composite	1/day	1
Oil and Grease	mg/L	grab	1/day	1
Total Suspended Solids (TSS)	mg/L	24-hr composite	1/day	1

<sup>1</sup> As required under 40 CFR 136.

### IV. EFFLUENT MONITORING REQUIREMENTS

#### A. Monitoring Location EFF-001

1. The Discharger shall monitor effluent at EFF-001 as follows.

**Table E-3. Effluent Monitoring**

Parameter	Units	Sample Type	Minimum Sampling Frequency	Required Analytical Test Method
Flow Rate	MGD	recorder/totalizer	continuous	1
BOD <sub>5</sub> @20 °C	mg/L	24-hr composite	1/day	1
	% removal	calculate	1/day	1
CBOD <sub>5</sub> @20 °C	mg/L	24-hr composite	1/month	1
Temperature	°C	grab	1/week	1
Total Residual Chlorine	µg/L	continuous	continuous	1
Dissolved Oxygen	mg/L	grab	1/week	1
TABLE A PARAMETERS				
Oil and Grease	mg/L	grab	1/week	1
Total Suspended Solids	mg/L	24-hr composite	1/day	1
	% removal	calculate	1/day	1
Settleable Solids	ml/L	grab	1/day	1
Turbidity	NTU	grab	1/week	1

Parameter	Units	Sample Type	Minimum Sampling Frequency	Required Analytical Test Method
pH	units	grab	1/day	1
<b>TABLE B PARAMETERS FOR PROTECTION OF MARINE AQUATIC LIFE</b>				
Arsenic, Total Recoverable	µg/L	24-hr composite	1/quarter	1
Cadmium, Total Recoverable	µg/L	24-hr composite	1/quarter	1
Chromium (VI), Total Recoverable <sup>2</sup>	µg/L	24-hr composite	1/quarter	1
Copper, Total Recoverable	µg/L	24-hr composite	1/month	1
Lead, Total Recoverable	µg/L	24-hr composite	1/quarter	1
Mercury, Total Recoverable	µg/L	24-hr composite	1/quarter	1
Nickel, Total Recoverable	µg/L	24-hr composite	1/quarter	1
Selenium, Total Recoverable	µg/L	24-hr composite	1/quarter	1
Silver, Total Recoverable	µg/L	24-hr composite	1/quarter	1
Zinc, Total Recoverable	µg/L	24-hr composite	1/quarter	1
Cyanide, Total Recoverable <sup>3</sup>	µg/L	24-hr composite	1/quarter	1
Ammonia (as N)	µg/L	24-hr composite	1/month	1
Phenolic Compounds (nonchlorinated)	µg/L	24-hr composite	1/quarter	1
Phenolic Compounds (chlorinated)	µg/L	24-hr composite	1/quarter	1
Endosulfan <sup>11</sup>	µg/L	24-hr composite	1/quarter	1
Endrin	µg/L	24-hr composite	1/quarter	1
HCH <sup>4</sup>	µg/L	24-hr composite	1/quarter	1
Radioactivity	pCi/l	24-hr composite	1/quarter	1
<b>TABLE B PARAMETERS FOR PROTECTION OF HUMAN HEALTH – NON CARCINOGENS</b>				
Acrolein	µg/L	grab	2/year	1
Antimony	µg/L	24-hr composite	2/year	1
Bis(2-chloroethoxy)methane	µg/L	grab	2/year	1

Parameter	Units	Sample Type	Minimum Sampling Frequency	Required Analytical Test Method
Bis(2-chloroisopropyl) Ether	µg/L	grab	2/year	1
Chlorobenzene	µg/L	grab	2/year	1
Chromium (III), Total Recoverable	µg/L	24-hr composite	2/year	1
Di-n-butyl Phthalate	µg/L	grab	2/year	1
Dichlorobenzenes <sup>5</sup>	µg/L	grab	2/year	1
Diethyl Phthalate	µg/L	grab	2/year	1
Dimethyl Phthalate	µg/L	grab	2/year	1
4,6-dinitro-2-methylphenol	µg/L	grab	2/year	1
2,4-dinitrophenol	µg/L	grab	2/year	1
Ethylbenzene	µg/L	grab	2/year	1
Fluoranthene	µg/L	grab	2/year	1
Hexachlorocyclopentadiene	µg/L	grab	2/year	1
Nitrobenzene	µg/L	grab	2/year	1
Thallium, Total Recoverable	µg/L	24-hr composite	2/year	1
Toluene	µg/L	grab	2/year	1
Tributyltin	µg/L	24-hr composite	2/year	1
1,1,1-trichloroethane	µg/L	grab	2/year	1
<b>TABLE B PARAMETERS FOR PROTECTION OF HUMAN HEALTH – CARCINOGENS</b>				
Acrylonitrile	µg/L	grab	2/year	1
Aldrin	µg/L	24-hr composite	2/year	1
Benzene	µg/L	grab	2/year	1
Benzidine	µg/L	grab	2/year	1
Beryllium	µg/L	24-hr composite	2/year	1
Bis(2-chloroethyl) Ether	µg/L	grab	2/year	1
Bis(2-ethylhexyl) Phthalate	µg/L	grab	2/year	1
Carbon Tetrachloride	µg/L	grab	2/year	1
Chlordane	µg/L	24-hr composite	2/year	1
Chlorodibromomethane	µg/L	grab	2/year	1
Chloroform	µg/L	grab	2/year	1
DDT <sup>6</sup>	µg/L	24-hr composite	2/year	1
1,4-dichlorobenzene	µg/L	grab	2/year	1
3,3'-dichlorobenzidine	µg/L	grab	2/year	1
1,2-dichloroethane	µg/L	grab	2/year	1
1,1-dichloroethylene	µg/L	grab	2/year	1
Dichlorobromomethane	µg/L	grab	2/year	1
Dichloromethane	µg/L	grab	2/year	1
1,3-dichloropropene	µg/L	grab	2/year	1
Dieldrin	µg/L	24-hr composite	2/year	1
2,4-dinitrotoluene	µg/L	grab	2/year	1
1,2-diphenylhydrazine	µg/L	grab	2/year	1
Halomethanes <sup>7</sup>	µg/L	grab	2/year	1
Heptachlor	µg/L	24-hr composite	2/year	1

Parameter	Units	Sample Type	Minimum Sampling Frequency	Required Analytical Test Method
Heptachlor Epoxide	µg/L	24-hr composite	2/year	1
Hexachlorobenzene	µg/L	grab	2/year	1
Hexachlorobutadiene	µg/L	grab	2/year	1
Hexachloroethane	µg/L	grab	2/year	1
Isophorone	µg/L	grab	2/year	1
N-nitrosodimethylamine	µg/L	grab	2/year	1
N-nitrosodi-N-propylamine	µg/L	grab	2/year	1
N-nitrosodiphenylamine	µg/L	grab	2/year	1
PAHs <sup>8</sup>	µg/L	24-hr composite	2/year	1
PCBs <sup>9</sup>	µg/L	24-hr composite	2/year	1
1,1,2,2-tetrachloroethane	µg/L	grab	2/year	1
TCDD equivalents <sup>10</sup>	µg/L	24-hr composite	2/year	1
Tetrachloroethylene	µg/L	grab	2/year	1
Toxaphene	µg/L	24-hr composite	2/year	1
Trichloroethylene	µg/L	grab	2/year	1
1,1,2-trichloroethane	µg/L	grab	2/year	1
2,4,6-trichlorophenol	µg/L	grab	2/year	1
Vinyl Chloride	µg/L	grab	2/year	1

- <sup>1</sup> As required under 40 CFR 136.
- <sup>2</sup> Dischargers may, at their option, meet this limitation (or apply this performance goal) as a total chromium limitation (or performance goal).
- <sup>3</sup> If a Discharger can demonstrate to the satisfaction of the Regional Water Board (subject to USEPA approval) that an analytical method is available to reliably distinguish between strongly and weakly complexed cyanide, effluent limitations for cyanide may be met by (or performance goals may be evaluated with) the combined measurement of free cyanide, simple alkali metals cyanides, and weakly complexed organometallic cyanide complexes. In order for the analytical method to be acceptable, the recovery of free cyanide from metal complexes must be comparable to that achieved by the approved method in 40 CFR 136, as revised May 14, 1999.
- <sup>4</sup> HCH (hexachlorocyclohexane) represents the sum of the alpha, beta, gamma (Lindane), and delta isomers of hexachlorocyclohexane.
- <sup>5</sup> Dichlorobenzenes represent the sum of 1,2- and 1,3-dichlorobenzene.
- <sup>6</sup> DDD (dichlorodiphenyldichloroethane), DDE (dichlorodiphenyldichloroethylene), and DDT (dichlorodiphenyltrichloroethane) represent the sum of 4,4' DDT; 2,4' DDT; 4,4' DDE; 2,4' DDE; 4,4' DDD; and 2,4' DDD.
- <sup>7</sup> Halomethanes represent the sum of bromoform, bromomethane (methyl bromide), and chloromethane (methyl chloride).
- <sup>8</sup> PAHs (polynuclear aromatic hydrocarbons) represent the sum of acenaphthalene; anthracene; 1,2-benzanthracene; 3,4-benzofluoranthene; benzo[k]fluoranthene; 1,1,2-benzoperylene; benzo[a]pyrene; chrysene; dibenzo[a,h]anthracene; fluorine; indeno[1,2,3-cd]pyrene; phenanthrene; and pyrene.
- <sup>9</sup> PCBs (polychlorinated biphenyls) represent the sum of chlorinated biphenyls whose analytical characteristics resemble those of Aroclor-1016, Aroclor-1221, Aroclor-1232, Aroclor-1242, Aroclor-1248, Aroclor-1254, and Aroclor-1260.
- <sup>10</sup> TCDD equivalents represent the sum of concentrations of chlorinated dibenzodioxins (2,3,7,8-CDDs) and chlorinated dibenzofurans (2,3,7,8-CDFs) multiplied by their respective toxicity factors, as shown by the table below. USEPA Method 8280 may be used to analyze TCDD equivalents.

Isomer Group	Toxicity Equivalence Factor
2,3,7,8 – tetra CDD	1.0
2,3,7,8 – penta CDD	0.5

Isomer Group	Toxicity Equivalence Factor
2,3,7,8 – hexa CDD	0.1
2,3,7,8 – hepta CDD	0.01
octa CDD	0.001
2,3,7,8 – tetra CDF	0.1
1,2,3,7,8 – penta CDF	0.05
2,3,4,7,8 – penta CDF	0.5
2,3,7,8 – hexa CDFs	0.1
2,3,7,8 – hepta CDFs	0.01
Octa CDF	0.001

<sup>11</sup> Endosulfan shall mean the sum of alpha-endosulfan, beta-endosulfan, and endosulfan sulfate.

## V. WHOLE EFFLUENT TOXICITY TESTING REQUIREMENTS

The Discharger shall conduct acute and chronic toxicity testing on effluent samples collected at Effluent Monitoring Station EFF-001 in accordance with the following schedule and requirements:

**Table E-4. Whole Effluent Toxicity Testing**

Test	Unit	Sample	Minimum Test Frequency
Acute Toxicity	TU <sub>a</sub>	24-hr composite	1/month
Chronic Toxicity	TU <sub>c</sub>	24-hr composite	1/month

Acute toxicity testing shall be performed using either a marine fish or invertebrate species in accordance with procedures established by the USEPA guidance manual, *Methods for Measuring the Acute Toxicity of Effluents and Receiving Waters to Freshwater and Marine Organisms*, 5<sup>th</sup> Edition, October 2002 (EPA-821-R-02-012).

Critical life stage toxicity tests shall be performed to measure chronic toxicity. Testing shall be performed using methods outlined in *Short-Term Methods for Estimating the Chronic Toxicity of Effluent and Receiving Waters to West Coast Marine Estuarine Organisms* (Chapman, G.A., D.L. Denton, and J.M. Lazorchak, 1995) or *Procedures Manual for Conducting Toxicity Tests Developed by the Marine Bioassay Project* (State Water Board, 1996).

A screening period for chronic toxicity shall be conducted every other year for three months, using a minimum of three test species with approved test protocols, from the following list (from the California Ocean Plan). Other tests may be used, if they have been approved for such testing by the State Water Board. The test species shall include a fish, an invertebrate, and an aquatic plant. After the screening period, the most sensitive test species shall be used for the month if the most sensitive species is the same as found previously to be most sensitive. Control and dilution water should be receiving water or lab water as appropriate. If the dilution water is different from the culture water, then culture water should be used in a second control. The sensitivity of the test organisms to a reference toxicant shall be determined concurrently with each bioassay test and reported with test results.



**Table E-5. Approved Test for Chronic Toxicity**

Species	Test	Tier <sup>1</sup>	Reference <sup>2</sup>
giant kelp, <i>Macrocystis pyrifera</i>	percent germination; germ tube length	1	a, c
red abalone, <i>Haliotis rufescens</i>	abnormal shell development	1	a, c
oyster, <i>Crassostrea gigas</i> ; mussels, <i>Mytilus spp.</i>	abnormal shell development; percent survival	1	a, c
urchin, <i>Strongylocentrotus purpuratus</i> ; sand dollar, <i>Dendraster excentricus</i>	percent normal development	1	a, c
urchin, <i>Strongylocentrotus purpuratus</i> ; sand dollar, <i>Dendraster excentricus</i>	percent fertilization	1	a, c
shrimp, <i>Homesimysis costata</i>	percent survival; growth	1	a, c
shrimp, <i>Mysidopsis bahia</i>	percent survival; fecundity	2	b, d
topsmelt, <i>Atherinops affinis</i>	larval growth rate; percent survival	1	a, c
Silversides, <i>Menidia beryllina</i>	larval growth rate; percent survival	2	b, d

<sup>1</sup> First tier methods are preferred for compliance monitoring. If first tier organisms are not available, the Discharger can use a second tier test method following approval by the Regional Water Board.

<sup>2</sup> Protocol References:

- a. Chapman, G.A., D.L. Denton, and J.M. Lazorchak. 1995. Short-term Methods for Estimating the Chronic Toxicity of Effluents and Receiving Waters to West Coast Marine and Estuarine Organisms. USEPA Report No. EPA/600/R-95/136.
- b. Klemm, D.J., G.E. Morrison, T.J. Norberg-King, W.J. Peltier, and M.A. Heber. 1994. Short-term Methods for Estimating the Chronic Toxicity of Effluents and Receiving Water to Marine and Estuarine Organisms. USEPA Report No. EPA-600-4-91-003.
- c. SWRCB 1996. Procedures Manual for Conducting Toxicity Tests Developed by the Marine Bioassay Project. 96-1WQ.
- d. Weber, C.I., W.B. Horning, I.I., D.J. Klemm, T.W. Nieheisel, P.A. Lewis, E.L. Robinson, J. Menkedick and F. Kessler (eds). 1998. Short-term Methods for Estimating the Chronic Toxicity of Effluents and Receiving Waters to Marine and Estuarine Organisms. EPA/600/4-87/028. National Information Service, Springfield, VA.

**VI. LAND DISCHARGE MONITORING REQUIREMENTS – NOT APPLICABLE**

**VII. RECLAMATION MONITORING REQUIREMENTS – NOT APPLICABLE**

**VIII. RECEIVING WATER MONITORING REQUIREMENTS – SURFACE WATER**

The receiving water and sediment monitoring program required herein may be conducted solely by the Discharger or jointly with the City of Oceanside, Fallbrook Public Utility District, and Genentech, Inc., as these entities discharge through the OOO.

**A. Surf Zone Water Quality Monitoring**

All surf zone stations shall be monitored as follows:

1. Grab samples shall be collected and analyzed for total and fecal coliform and enterococcus bacteria at a minimum frequency of one time per week. As required

by implementation procedures at section III. D of the Ocean Plan (2001), measurement of enterococcus density shall be conducted at all stations where measurement of total and fecal coliform bacteria is required. When a shore station consistently exceeds a coliform objective or exceeds a geometric mean enterococcus density of 24 organisms per 100 mL for a 30-day period or 12 organisms per 100 mL for a 6-month period, the Discharger shall conduct a sanitary survey, if so directed by the Regional Water Board, to determine if the Facility is the source of the contamination.

2. Samples shall be collected in accordance with “Standard Operating Procedures for the Collection of Water Samples for Bacterial Analysis from Ocean and Bay Receiving Waters” developed by the County of San Diego Department of Environmental Health and incorporated herein by reference.
3. At the same time samples are collected from surf zone stations, the following information shall be recorded: observation of wind direction and speed; weather (cloudy, sunny, or rainy); current direction; tidal conditions; and observations of water color, discoloration, oil and grease; turbidity, odor, and materials of sewage origin in the water or on the beach; water temperature (° F); and status of the mouth of the Buena Vista Lagoon (open, closed, flow, etc.).
4. If a surf zone water quality monitoring station consistently exceeds a coliform objective or exceeds a geometric mean enterococcus density of 24 organisms per 100 mL for a thirty day period or 12 organisms per 100 mL for a six month period, the Discharger shall conduct a survey to determine if discharges from the Discharger’s Facility is the source of the contamination. If the survey indicates that elevated coliform and/or enterococcus levels are attributable to discharges from the Discharger’s Facility, the Discharger shall take action to control the source.

**B. Near Shore Water Quality Monitoring**

**1. Reduced Monitoring**

If the Executive Officer determines that the effluent at all times complies with Section IV.A, Effluent Limitations and Performance Goals and Section V.B, Receiving Water Limitations, of Order No. R9-2008-0096, only reduced near shore water quality monitoring specified below is required.

**Table E-6. Near Shore Water Quality Reduced Monitoring Requirements**

Determination	Units	Type of Sample	Minimum Frequency
Visual Observations	-	-	1/month
Total and Fecal Coliform	number / 100 ml	grab <sup>1</sup>	1/month
Enterococcus	number / 100 ml	grab <sup>1</sup>	1/month

<sup>1</sup> At the surface.

<sup>2</sup> If the Discharger demonstrates to the satisfaction of the Executive Officer, by means of daily analyses, that the concentrations of total and fecal coliform bacteria in the effluent are consistently less than 1,000 per mL, enterococcus monitoring may be suspended. The Discharger shall conduct the monitoring as specified unless the Executive Officer provides written authorization to suspend it. If this monitoring is suspended, the Discharger shall resume it at the request of the Executive Officer.

## 2. Intensive Monitoring

The intensive near shore water quality monitoring specified below is required during the 12-month period beginning July 1, 2008 through June 30, 2009, and must be submitted by August 31, 2009. This monitoring data will assist Regional Water Board staff in the evaluation of the Report of Waste Discharge. The intensive near shore water quality monitoring specified below is also required if the Executive Officer determines that the effluent does not at all times comply with Section IV.A Effluent Limitations and Performance Goals and Section V.B, Receiving Water Limitations, of Order No. R9-2008-0096.

**Table E-7. Near Shore Water Quality Reduced Monitoring Requirements**

Determination	Units	Type of Sample	Minimum Frequency
Visual Observations	-	-	1/month
Total and Fecal Coliform	number / 100 ml	grab <sup>1</sup>	1/month
Enterococcus	number / 100 ml	grab <sup>1</sup>	1/month

<sup>1</sup> At the surface and mid-depth.

## C. Off Shore Water Quality Monitoring

### 1. Intensive Monitoring

The intensive off shore water quality monitoring specified below is required during the 12-month period beginning July 1, 2008 through June 30, 2009, and must be submitted by August 31, 2009. This monitoring data will assist Regional Water Board staff in the evaluation of the Report of Waste Discharge. The intensive off shore water quality monitoring specified below is also required if the Executive Officer determines that the effluent does not at all times comply with Section IV.A Effluent Limitations and Performance Goals and Section V.B, Receiving Water Limitations, of Order No. R9-2008-0096.

**Table E-9. Near Shore Water Quality Reduced Monitoring Requirements**

Determination	Units	Type of Sample	Minimum Frequency
Visual Observations	-	-	1/month
Total and Fecal Coliform	number / 100 ml	grab <sup>1</sup>	1/month
Enterococcus	number / 100 ml	grab <sup>1</sup>	1/month
Conductivity, Temperature and Depth (CTD)	Practical salinity units, °C, feet	instrument <sup>2</sup>	1/month
Dissolved Oxygen	mg/L	grab <sup>3</sup>	1/month
Light Transmittance	percent	instument <sup>3</sup>	
pH	pH units	grab <sup>4</sup>	1/month

<sup>1</sup> At the surface and mid-depth.

<sup>2</sup> At 1-meter intervals, surface to bottom.

<sup>3</sup> At the surface, mid-depth, and bottom.

<sup>4</sup> At the surface.

## D. Benthic Monitoring

The monitoring specified below is required during the 12-month period beginning July 1, 2008 through June 30, 2009. The monitoring data will assist Regional Water Board staff in the evaluation of the Report of Waste Discharge, which is required to be submitted by the Discharger within 180 days prior to the Order's expiration date. Benthic monitoring shall be conducted at all offshore monitoring stations.

- 1. Sediment Characteristics.** Analyses shall be performed on the upper two inches of core.

**Table E-10. Sediment Monitoring Requirements**

Determination	Units	Type of Sample	Minimum Frequency
Sulfides	mg/kg	core	2/year
Total Chlorinated	mg/kg	core	2/year
Hydrocarbons	mg/kg	core	2/year
BOD <sub>5</sub>	mg/kg	core	2/year
COD	mg/kg	core	2/year
Particle Size Distribution	mg/kg	core	2/year
Arsenic	mg/kg	core	1/year
Cadmium	mg/kg	core	1/year
Total Chromium	mg/kg	core	1/year
Copper	mg/kg	core	1/year
Lead	mg/kg	core	1/year
Mercury	mg/kg	core	1/year
Nickel	mg/kg	core	1/year
Silver	mg/kg	core	1/year
Zinc	mg/kg	core	1/year
Cyanide	mg/kg	core	1/year
Phenolic Compounds	mg/kg	core	1/year
Radioactivity	pCi/kg	core	1/year

- 2. Infauna.** Samples shall be collected with a Paterson, Smith-McIntyre, or orange-peel type dredge, having an open sampling area of not less than 124 square inches and a sediment capacity of not less than 210 cubic inches. The sediment shall be sifted through a one millimeter mesh screen and all organisms shall be identified to as low a taxon as possible.

**Table E-11. Infauna Monitoring Requirements**

Determination	Units	Sample Type	Minimum Frequency
Benthic Biota	Identification and enumeration	3 grabs	2/year

**E. Additional Biological Monitoring**

Demersal Fish and Macroinvertebrates

The monitoring specified below is required during the 12-month period beginning July 1, 2008 through June 30, 2009. The monitoring data will assist Regional Water Board staff in the evaluation of the Report of Waste Discharge, which is required to be submitted by the Discharger within 180 days prior to the Order’s expiration date of June 1, 2011.

**Table E-12. Demersal Fish and Macroinvertebrates Monitoring Requirements**

<b>Determination</b>	<b>Units</b>	<b>Minimum Frequency</b>
Biological Transects	Identification and enumeration	Year 4

In rocky or cobble areas, a 30-meter band transect, one meter wide, shall be established on the ocean bottom. Operations at each underwater station shall include: (1) recording of water temperature (may be measured from a boat) and estimated visibility and pelagic macrobiota at each 10-foot depth increment throughout the water column and at the bottom; (2) recording of general bottom description; (3) enumeration by estimate of the larger plants and animals in the band transect area; (4) development of a representative photographic record of the sample area; and (5) within each band, three one-quarter meter square areas shall be randomly selected, and all macroscopic plant and animal life shall be identified within each square to as low a taxon as possible, and measured. Sampling techniques will follow those employed by biologist divers of the California State Department of Fish and Game.

In sandy areas, a 30-meter band transect, one meter wide, shall be established on the ocean bottom. Operations at each underwater station shall include: (1) recording of water temperature (may be measured from a boat), and estimated visibility and pelagic macrobiota at each 10-foot depth increment throughout the water column and at the bottom; (2) recording of general bottom description; (3) recording of height, period, and crest direction of ripple marks; (4) recording of amount, description, and location of detritus on bottom; (5) creation of a representative photographic record of the area sampled; and (6) within each band, three cores of at least 42.5 cm<sup>2</sup> in area shall be randomly taken to a depth of 15 cm where possible, (the three cores may be taken from a boat) and the material removed sifted through at least a 1 mm mesh screen, and all organisms identified to as low a taxon as possible, enumerated, measured, and reproductive conditions assessed where feasible. Sampling techniques will follow those employed by biologist divers of the California State Department of Fish and Game.

For each epifauna and infauna, size frequency and distribution shall be shown for at least the three numerically largest populations identified to the lowest possible taxon and appropriate graphs showing the relationship between species frequency and population shall be plotted from each sample.

## **IX. OTHER MONITORING REQUIREMENTS**

### **A. Kelp Bed Canopy**

The Discharger shall participate with other ocean dischargers in the San Diego Region in an annual regional kelp bed photographic survey. Kelp beds shall be monitored annually by means of vertical aerial infrared photography to determine the maximum aerial extent of the region's coastal kelp beds within the calendar year. Surveys shall be conducted as close as possible to the time when kelp bed canopies cover the greatest area. The entire San Diego Region coastline, from the international boundary to the San Diego Region/Santa Ana Region boundary shall be photographed on the same day. The images produced by the surveys shall be presented in the form of 1:24,000 scale photo-mosaic of the entire San Diego Region coastline. Onshore reference points, locations of all ocean outfalls and diffusers, and the 30-foot mean lower low water (MLLW) and 60-foot (MLLW) depth contours shall be shown. The aerial extent of the various kelp beds photographed in each survey shall be compared to that noted in surveys of previous years. Any significant losses which persist for more than one year shall be investigated by divers to determine the probable reason for the loss.

### **B. Regional Monitoring**

The Discharger shall participate in regional monitoring activities coordinated by the Southern California Coastal Water Project (SCCWRP). The intent of regional monitoring activities is to maximize the efforts of all monitoring partners using a more cost-effective monitoring design and to best utilize the pooled scientific resources of the region. During these coordinated sampling efforts, the Discharger's sampling and analytical effort may be reallocated to provide a regional assessment of the impact of the discharge of municipal wastewater to the Southern California Bight. Anticipated modifications to the monitoring program will be coordinated so as to provide a more comprehensive picture of the ecological and statistical significance of monitoring results and to determine cumulative impacts of various pollution sources. The level of effort will be provided to the Executive Officer and USEPA for approval.

### **C. Solids Monitoring**

The Discharger shall report, annually, the volume of screenings, sludge [biosolids], grit, and other solids generated and/or removed during wastewater treatment and the locations where these waste materials are placed for disposal. Copies of all annual reports required by 40 CFR 503 shall be submitted to the Regional Water Board at the same time they are submitted to the USEPA.

### **D. Sanitary Sewer Overflow**

1. All Dischargers must obtain sanitary sewer overflow (SSO) Database accounts and receive a "Username" and "Password" by registering through the California Integrated Water Quality System (CIWQS). These accounts will allow controlled and secure entry into the SSO Database. Additionally, within thirty (30) days of receiving an account and prior to recording SSOs into the SSO Database, all Dischargers

must complete the "Collection System Questionnaire", which collects pertinent information regarding an Discharger's collection system. The "Collection System Questionnaire" must be updated at least every 12 months.

2. All SSOs that meet the criteria for Category 1 SSOs, as defined in Attachment A, must be reported as soon as: (1) the Discharger has knowledge of the discharge, (2) reporting is possible, and (3) reporting can be provided without substantially impeding cleanup or other emergency measures. Initial reporting of Category 1 SSOs must be reported to the Online SSO System, described above, as soon as possible but no later than 3 business days after the Discharger is made aware of the SSO. Minimum information that must be contained in the 3-day report must include all information identified in section 6 below, except for item 6.k. A final certified report must be completed through the Online SSO System, within 15 calendar days of the conclusion of SSO response and remediation. Additional information may be added to the certified report, in the form of an attachment, at any time.
3. All SSOs that meet the above criteria for Category 2 SSOs must be reported to the Online SSO Database within 30 days after the end of the calendar month in which the SSO occurs (e.g. all SSOs occurring in the month of January must be entered into the database by March 1st).
4. If there are no SSOs during the calendar month, the Discharger will provide, within 30 days after the end of each calendar month, a statement through the Online SSO Database certifying that there were no SSOs for the designated month.
5. In the event that the SSO Online Database is not available, the Discharger must fax all required information to the appropriate Regional Water Board office in accordance with the time schedules identified above. In such event, the Discharger must also enter all required information into the Online SSO Database as soon as practical.
6. At a minimum, the following mandatory information must be included prior to finalizing and certifying an SSO report for each category of SSO:

**Category 2 SSOs:**

- a. Location of SSO by entering GPS coordinates;
- b. Applicable Regional Water Board, i.e. identify the region in which the SSO occurred;
- c. County where SSO occurred;
- d. Whether or not the SSO entered a drainage channel and/or surface water;
- e. Whether or not the SSO was discharged to a storm drain pipe that was not fully captured and returned to the sanitary sewer system;
- f. Estimated SSO volume in gallons;
- g. SSO source (manhole, cleanout, etc.);
- h. SSO cause (mainline blockage, roots, etc.);
- i. Time of SSO notification or discovery;

- j. Estimated operator arrival time;
- k. SSO destination;
- l. Estimated SSO end time; and
- m. SSO Certification. Upon SSO Certification, the SSO Database will issue a Final SSO Identification (ID) Number.

**Category 1 SSOs:**

- a. All information listed for Category 2 SSOs, as well as;
  - b. Estimated SSO volume that reached surface water, drainage channel, or not recovered from a storm drain;
  - c. Estimated SSO amount recovered;
  - d. Response and corrective action taken;
  - e. If samples were taken, identify which regulatory agencies received sample results (if applicable). If no samples were taken, NA must be selected.
  - f. Parameters that samples were analyzed for (if applicable);
  - g. Identification of whether or not health warnings were posted;
  - h. Beaches impacted (if applicable). If no beach was impacted, NA must be selected;
  - i. Whether or not there is an ongoing investigation;
  - j. Steps taken or planned to reduce, eliminate, and prevent reoccurrence of the overflow and a schedule of major milestones for those steps;
  - k. OES control number (if applicable);
  - l. Date OES was called (if applicable);
  - m. Time OES was called (if applicable);
  - n. Identification of whether or not County Health Officers were called;
  - o. Date County Health Officer was called (if applicable); and
  - p. Time County Health Officer was called (if applicable).
7. The Discharger shall comply with all applicable reporting requirements of this Order, including Provision V.E of Attachment D (24-hour reporting requirement).
8. The Discharger shall report SSOs to OES, in accordance with California Water Code Section 13271.
- Office of Emergency Services  
Phone (800) 852-7550
9. The Discharger shall report SSOs to County Health officials in accordance with California Health and Safety Code Section 5410 et seq.
10. The SSO database will automatically generate an e-mail notification with customized information about the SSO upon initial reporting of the SSO and final certification for all Category 1 SSOs. E-mails will be sent to the appropriate County Health Officer and/or Environmental Health Department if the county desires this information, and the appropriate Regional Water Board.



## **E. General Monitoring and Reporting Requirements**

- 1.** The Discharger shall comply with all Standard Provisions (Attachment D) related to monitoring, reporting, and recordkeeping.
- 2.** Reports of marine monitoring surveys conducted to meet receiving water monitoring requirements of this MRP shall include, as a minimum, the following information:
  - a.** A description of climatic and receiving water characteristics at the time of sampling (weather observations, floating debris, discoloration, wind speed and direction, swell or wave action, time of sampling, tide height, etc.
  - b.** A description of sampling stations, including differences unique to each station (e.g., station location, sediment grain size, distribution of bottom sediments, rocks, shell litter, calcareous worm tubes, etc.).
  - c.** A description of the sample collection and preservation procedures used in the survey.
  - d.** A description of the specific method used for laboratory analysis.
  - e.** An in-depth discussion of the results of the survey. All tabulations and computations shall be explained.
  - f.** Annual reports will be due July 1<sup>st</sup> and will include detailed statistical analyses of all data. Methods may include, but are not limited to, various multivariate analyses such as cluster analysis, ordination, and regression. The Discharger should also conduct additional analyses, as appropriate, to elucidate temporal and spatial trends in the data.
- 3.** The Discharger shall report all instances of noncompliance not reported under Attachment D, sections III, V, and VI of this Order No. R9-2008-0096 at the time monitoring reports are submitted.
- 4.** By February 1 of each year, the Discharger shall submit an annual report to the Regional Water Board and USEPA Region 9 that contains tabular and graphical summaries of the monitoring data obtained during the previous year. The Discharger shall discuss the compliance record and corrective actions taken, or which may be taken, or which may be needed to bring the discharge into full compliance with the requirements of Order No. R9-2008-0096 and this MRP.
- 5.** By February 1 of each year, the Discharger shall submit the annual Industrial Waste Survey report to the Regional Water Board describing its source control program activities over the previous calendar year as specified in section VI.C.5.b.ii.(a) of Order No. R9-2008-0096.
- 6.** The Discharger shall retain records of all SSOs, such as, but not limited to and when applicable:

- a. Record of Certified report, as submitted to the online SSO database;
- b. All original recordings for continuous monitoring instrumentation;
- c. Service call records and complaint logs of calls received by the Discharger;
- d. SSO calls;
- e. SSO records;
- f. Steps that have been and will be taken to prevent the SSO from recurring and a schedule to implement those steps.
- g. Work orders, work completed, and any other maintenance records from the previous 5 years which are associated with responses and investigations of system problems related to SSOs;
- h. A list and description of complaints from customers or others from the previous 5 years; and
- i. Documentation of performance and implementation measures for the previous 5 years.

### F. Self Monitoring Reports (SMRs)

1. At any time during the term of this permit, the State or Regional Water Board may notify the Discharger to electronically submit Self-Monitoring Reports (SMRs) using the State Water Board's California Integrated Water Quality System (CIWQS) Program Web site (<http://www.waterboards.ca.gov/ciwqs/index.html>). Until such notification is given, the Discharger shall submit hard copy SMRs. The CIWQS Web site will provide additional directions for SMR submittal in the event there will be service interruption for electronic submittal.
2. The Discharger shall report in the SMR the results for all monitoring specified in this MRP under sections III through IX. The Discharger shall submit monthly SMRs including the results of all required monitoring using USEPA-approved test methods or other test methods specified in this Order. If the Discharger monitors any pollutant more frequently than required by this Order, the results of this monitoring shall be included in the calculations and reporting of the data submitted in the SMR.
3. Monitoring periods and reporting for all required monitoring shall be completed according to the following schedule:

**Table E-13. Monitoring Periods and Reporting Schedule**

Sampling Frequency	Monitoring Period Begins	Monitoring Period	SMR Due Date
Continuous	November 1, 2008	All	Submit with monthly SMR
Hourly	November 1, 2008	Hourly	Submit with monthly SMR
Daily	November 1, 2008	(Midnight through 11:59 PM) or any 24-hour period that reasonably represents a calendar day for purposes of sampling.	Submit with monthly SMR
Weekly	November 2, 2008	Sunday through Saturday	Submit with monthly SMR

Monthly	November 1, 2008	1 <sup>st</sup> day of calendar month through last day of calendar month	30 days from the end of the monitoring period
Quarterly	January 1, 2009	January 1 through March 31 April 1 through June 30 July 1 through September 30 October 1 through December 31	30 days from the end of the monitoring period
Semiannually	January 1, 2009	January 1 through June 30 July 1 through December 31	30 days from the end of the monitoring period
Annually	January 1, 2009	January 1 through December 31	30 days from the end of the monitoring period

- 4. Reporting Protocols.** The Discharger shall report with each sample result the applicable reported Minimum Level (ML) and the current Method Detection Limit (MDL), as determined by the procedure in Part 136. For each numeric effluent limitation or performance goal for a parameter identified in Table B of the Ocean Plan, the Discharger shall not use a ML greater than that specified in Appendix II of the Ocean Plan.

The Discharger shall report the results of analytical determinations for the presence of chemical constituents in a sample using the following reporting protocols:

- a.** Sample results greater than or equal to the reported ML shall be reported as measured by the laboratory (i.e., the measured chemical concentration in the sample).
- b.** Sample results less than the reporting level (RL), but greater than or equal to the laboratory’s MDL, shall be reported as “Detected, but Not Quantified,” or DNQ. The estimated chemical concentration of the sample shall also be reported.

For the purposes of data collection, the laboratory shall write the estimated chemical concentration next to DNQ as well as the words “Estimated Concentration” (may be shortened to “Est. Conc.”). The laboratory may, if such information is available, include numerical estimates of the data quality for the reported result. Numerical estimates of data quality may be percent accuracy (+ a percentage of the reported value), numerical ranges (low to high), or any other means considered appropriate by the laboratory.

- c.** Sample results less than the laboratory’s MDL shall be reported as “Not Detected,” or ND.
- d.** Dischargers are to instruct laboratories to establish calibration standards so that the ML value (or its equivalent if there is differential treatment of samples relative to calibration standards) is the lowest calibration standard. At no time is the Discharger to use analytical data derived from extrapolation beyond the lowest point of the calibration curve.

5. **Compliance Determination.** Compliance with effluent limitations for reportable pollutants shall be determined using sample reporting protocols defined above and Attachment A of this Order. For purposes of reporting and administrative enforcement by the Regional and State Water Boards, the Discharger shall be deemed out of compliance with effluent limitations if the concentration of the reportable pollutant in the monitoring sample is greater than the effluent limitation and greater than or equal to the reported ML.
6. **Multiple Sample Data.** When determining compliance with a measure of central tendency (arithmetic mean, geometric mean, median, etc.) of multiple sample analyses and the data set contains one or more reported determinations of DNQ or ND, the Discharger shall compute the median in place of the arithmetic mean in accordance with the following procedure:
  - a. The data set shall be ranked from low to high, ranking the reported ND determinations lowest, DNQ determinations next, followed by quantified values (if any). The order of the individual ND or DNQ determinations is unimportant.
  - b. The median value of the data set shall be determined. If the data set has an odd number of data points, then the median is the middle value. If the data set has an even number of data points, then the median is the average of the two values around the middle unless one or both of the points are ND or DNQ, in which case the median value shall be the lower of the two data points where DNQ is lower than a value and ND is lower than DNQ.
7. The Discharger shall submit SMRs in accordance with the following requirements:
  - a. The Discharger shall arrange all reported data in a tabular format. The data shall be summarized to clearly illustrate whether the facility is operating in compliance with interim and/or final effluent limitations. The Discharger is not required to duplicate the submittal of data that is entered in a tabular format within CIWQS. When electronic submittal of data is required and CIWQS does not provide for entry into a tabular format within the system, the Discharger shall electronically submit the data in a tabular format as an attachment.
  - b. The Discharger shall attach a cover letter to the SMR. The information contained in the cover letter shall clearly identify violations of the WDRs; discuss corrective actions taken or planned; and the proposed time schedule for corrective actions. Identified violations must include a description of the requirement that was violated and a description of the violation.
  - c. SMRs must be submitted to the Regional Water Board, signed and certified as required by the Standard Provisions (Attachment D), to the address listed below:

**9174 Sky Park Court, Suite 100  
San Diego, CA 92123-4340**

**G. Discharge Monitoring Reports (DMRs)**

1. As described in Section X.B.1 above, at any time during the term of this permit, the State or Regional Water Board may notify the Discharger to electronically submit SMRs that will satisfy federal requirements for submittal of Discharge Monitoring Reports (DMRs). Until such notification is given, the Discharger shall submit DMRs in accordance with the requirements described below.
2. DMRs must be signed and certified as required by the standard provisions (Attachment D). The Discharger shall submit the original DMR and one copy of the DMR to the address listed below:

<b>STANDARD MAIL</b>	<b>FEDEX/UPS/ OTHER PRIVATE CARRIERS</b>
State Water Resources Control Board Division of Water Quality c/o DMR Processing Center PO Box 100 Sacramento, CA 95812-1000	State Water Resources Control Board Division of Water Quality c/o DMR Processing Center 1001 I Street, 15 <sup>th</sup> Floor Sacramento, CA 95814

3. All discharge monitoring results must be reported on the official USEPA pre-printed DMR forms (EPA Form 3320-1). Forms that are self-generated will not be accepted unless they follow the exact same format of USEPA Form 3320-1.

**H. Other Reports**

1. The Discharger shall report the results of any acute and chronic toxicity testing, TRE/TIE, Treatment Plan Capacity Study, Sludge Disposal Report, and IWS Report, as required by Special Provisions – VI.C. of this Order. The Discharger shall submit reports with the first monthly SMR scheduled to be submitted on or immediately following the report due date.

## ATTACHMENT F – FACT SHEET

### Table of Contents

I.	Permit Information .....	F-3
II.	Facility Description .....	F-4
	A. Description of Wastewater and Biosolids Treatment or Controls .....	F-4
	B. Discharge Points and Receiving Waters.....	F-6
	C. Summary of Existing Requirements and Self-Monitoring Report (SMR) Data .....	F-7
	D. Compliance Summary.....	F-10
	E. Planned Changes – Not Applicable .....	F-11
III.	Applicable Plans, Policies, and Regulations.....	F-11
	A. Legal Authorities .....	F-11
	B. California Environmental Quality Act (CEQA) .....	F-11
	C. State and Federal Regulations, Policies, and Plans .....	F-12
	D. Impaired Water Bodies on CWA 303(d) List .....	F-13
	E. Other Plans, Policies and Regulations.....	F-14
	1. Secondary Treatment Regulations.....	F-14
	2. Storm Water.....	F-14
IV.	Rationale For Effluent Limitations and Discharge Specifications.....	F-14
	A. Discharge Prohibitions.....	F-14
	B. Technology-based Effluent Limitations .....	F-15
	1. Scope and Authority.....	F-15
	2. Applicable Technology-based Effluent Limitations.....	F-15
	C. Water Quality-based Effluent Limitations (WQBELs).....	F-17
	1. Scope and Authority.....	F-17
	2. Applicable Beneficial Uses and Water Quality Criteria and Objectives.....	F-17
	3. Determining the Need for WQBELs .....	F-18
	4. WQBEL Calculations .....	F-22
	5. Whole Effluent Toxicity (WET) .....	F-25
	D. Final Effluent Limitations.....	F-25
	E. Performance Goals.....	F-26
	1. Satisfaction of Anti-Backsliding Requirements.....	F-32
	2. Satisfaction of Antidegradation Policy.....	F-33
	3. Stringency of Requirements for Individual Pollutants.....	F-35
	F. Interim Effluent Limitations – Not Applicable.....	F-35
	G. Land Discharge Specifications – Not Applicable.....	F-35
	H. Reclamation Specifications – Not Applicable.....	F-35
V.	Rationale for Receiving Water Limitations.....	F-35
VI.	Rationale for Monitoring and Reporting Requirements.....	F-35
	A. Influent Monitoring .....	F-36
	B. Effluent Monitoring.....	F-36
	C. Whole Effluent Toxicity Testing Requirements .....	F-36
	D. Receiving Water Monitoring.....	F-36
	1. Surface Water.....	F-36
	E. Other Monitoring Requirements.....	F-37

VII. Rationale for Provisions.....	F-38
A. Standard Provisions.....	F-38
B. Special Provisions.....	F-38
1. Reopener Provisions.....	F-38
2. Special Studies and Additional Monitoring Requirements.....	F-38
3. Best Management Practices and Pollution Prevention – Not Applicable .....	F-39
4. Construction, Operation, and Maintenance Specifications – Not Applicable.....	F-39
5. Special Provisions for Municipal Facilities (POTWs Only) .....	F-39
6. Other Special Provisions – Not Applicable.....	F-40
7. Compliance Schedules - Not Applicable .....	F-40
VIII. Public Participation .....	F-40
A. Notification of Interested Parties .....	F-40
B. Written Comments .....	F-41
C. Public Hearing .....	F-41
D. Waste Discharge Requirements Petitions.....	F-41
E. Information and Copying.....	F-41
F. Register of Interested Persons .....	F-42
G. Additional Information .....	F-42

**List of Tables**

Table F-1. Facility Information .....	F-3
Table F-2. Dischargers to OOO.....	F-6
Table F-3a. Historic Effluent Limitations and Monitoring Data (BOD <sub>5</sub> and TSS) .....	F-7
Table F-3b. Historic Effluent Limitations and Monitoring Data (Ocean Plan Parameters – Table A).....	F-8
Table F-3c. Historic Effluent Limitations and Monitoring Data (Ocean Plan Parameters – Table B, for Protection of Aquatic Life).....	F-8
Table F-3d. Historic Effluent Limitations and Monitoring Data (Ocean Plan Parameters – Table B, for Protection of Human Health).....	F-8
Table F-4. Basin Plan Beneficial Uses .....	F-12
Table F-5. Ocean Plan Beneficial Uses.....	F-12
Table F-6. Summary of Technology-based Effluent Limitations for Secondary Treatment Facilities Established by USEPA at 40 CFR 133.102.....	F-15
Table F-7. Summary of Technology-based Effluent Limitations from Table A of the Ocean Plan.....	F-15
Table F-8. RPA Results Summary.....	F-19
Table F-9. Pollutants Having Background Concentrations .....	F-23
Table F-10. Example Parameter Water Quality Objectives .....	F-23
Table F-11. Summary of Water Quality-based Effluent Limitations .....	F-24
Table F-12. Effluent Limitations Based on Secondary Treatment Standards and Table A of the Ocean Plan. ....	F-25
Table F-13. Effluent Limitations Based on the Ocean Plan .....	F-25
Table F-14. Performance Goals Based on the Ocean Plan.....	F-27

## ATTACHMENT F – FACT SHEET

As described in section II of this Order, this Fact Sheet includes the legal requirements and technical rationale that serve as the basis for the requirements of this Order.

This Order has been prepared under a standardized format to accommodate a broad range of discharge requirements for Dischargers in California. Only those sections or subsections of this Order that are specifically identified as “not applicable” have been determined not to apply to this Discharger. Sections or subsections of this Order not specifically identified as “not applicable” are fully applicable to this Discharger.

### I. PERMIT INFORMATION

The following table summarizes administrative information related to the facility.

**Table F-1. Facility Information**

<b>WDID</b>	<b>9 000001182</b>
<b>Discharger</b>	<b>Marine Corps Base, Camp Pendleton</b>
<b>Name of Facility</b>	<b>Southern Region Tertiary Treatment Plant</b>
<b>Facility Address</b>	<b>Marine Corps Base</b>
	<b>Camp Pendleton, CA 92055</b>
	<b>San Diego County</b>
<b>Facility Contact, Title and Phone</b>	<b>Khalique Khan, Environmental Engineering Division Head, Assistant Chief of Staff, Environmental Security, (760) 725-0141</b>
<b>Authorized Person to Sign and Submit Reports</b>	<b>Khalique Khan, Environmental Engineering Division Head, Assistant Chief of Staff, Environmental Security, (760) 725-0141</b>
<b>Mailing Address</b>	<b>Box 555008, Camp Pendleton, CA 92055</b>
<b>Billing Address</b>	<b>Same as Mailing Address</b>
<b>Type of Facility</b>	<b>Wastewater Treatment Facility For Military Base (Federal Facility)</b>
<b>Major or Minor Facility</b>	<b>Major</b>
<b>Threat to Water Quality</b>	<b>1</b>
<b>Complexity</b>	<b>A</b>
<b>Pretreatment Program</b>	<b>No – Source Control Program</b>
<b>Reclamation Requirements</b>	<b>Producer</b>
<b>Facility Permitted Flow</b>	<b>3.6 million gallons per day (MGD)</b>
<b>Facility Design Flow</b>	<b>5.0 MGD</b>
<b>Watershed</b>	<b>Pacific Ocean</b>
<b>Receiving Water</b>	<b>Pacific Ocean</b>
<b>Receiving Water Type</b>	<b>Ocean waters</b>

- A.** The Marine Corps Base, Camp Pendleton (hereinafter Discharger) is the owner and operator of the Camp Pendleton Southern Region Tertiary Treatment Plant (hereinafter SRTTP or Facility), a wastewater treatment plant owned and operated by the United States Marine Corps, subject to the same requirements of a publicly owned treatment



works.

For the purposes of this Order, references to the “discharger” or “permittee” in applicable federal and State laws, regulations, plans, or policy are held to be equivalent to references to the Discharger herein.

- B. The Facility discharges wastewater to the Pacific Ocean, a water of the United States, and is currently regulated by Regional Water Board Order No. R9-2003-0155 which was adopted on August 13, 2003. Addendum No. 1 to Order No. R9-2003-0155 was adopted on November 12, 2003, which revises surf zone monitoring requirements of the monitoring and reporting program. Addendum No. 2 to Order No. R9-2003-0155 was adopted on August 16, 2006, which authorized the discharge of wastewater from the new SRTTP to the Oceanside Ocean Outfall (OOO) under Order No. R9-2003-0155, and decommissioned Treatment Plant No. 13. Order No. R9-2003-0155 expires on August 13, 2008. The terms and conditions of the current Order have been automatically continued and remain in effect until new Waste Discharge Requirements (WDRs) and National Pollutant Discharge Elimination System (NPDES) permit are adopted pursuant to this Order.
- C. The Discharger filed a report of waste discharge (ROWD) and submitted an application for renewal of its WDRs and NPDES permit on February 14, 2007. Supplemental information was requested on March 19, 2008 and received on April 3, 2008. A site visit was conducted on March 18 - 19, 2008, to observe operations and collect additional data to develop permit limitations and conditions.

## **II. FACILITY DESCRIPTION**

### **A. Description of Wastewater and Biosolids Treatment or Controls**

Order No. R9-2003-0155 authorized the discharge of up to 3.6 million gallons per day of treated wastewater to the Pacific Ocean through the City of Oceanside’s OOO, from four treatment plants located on Camp Pendleton (Treatment Plant Nos. 1, 2, 3, and 13). In the past, these four treatment facilities have provided secondary treatment for domestic and industrial waste discharges from portions of Camp Pendleton. In addition, Treatment Plant Nos. 1 and 2 have provided reclaimed water for irrigation of the Marine Memorial Golf Course.

On August 16, 2006 the Regional Water Board amended Order No. R9-2003-0155, allowing the Discharger to divert sewage previously treated at Treatment Plant No. 13 to a new treatment plant, the SRTTP. Since August 13, 2007 the SRTTP has been providing tertiary treatment for the sewage that was previously treated at Treatment Plant No. 13, approximately 1.3 MGD of wastewater. The tertiary-treated wastewater from the SRTTP has been combining with the secondary treated effluents from Treatment Plant Nos. 1, 2, and 3 at a central pump station (Lemon Grove Pump Station) for discharge to the Pacific Ocean through the OOO. The total volume of discharge to the OOO remains under the permitted allowable rate of 3.6 MGD.

In the summer of 2008 (prior to the adoption date of this Order), the wastewater conveyance pipelines to divert sewage from Treatment Plant Nos. 1, 2, and 3 to the SRTTP was completed. And Treatment Plant Nos. 1, 2, and 3 have been converted to pump stations.

Treatment Plant Nos. 1, 2, and 3 are no longer used by the Discharger for sewage treatment, and all influent flow is now routed to the SRTTP.

Recycle and reuse lines have been constructed to carry tertiary-treated effluent from the SRTTP to storage facilities located on-base for use under a WDR Master Reclamation permit. The use of the reclaimed water from the SRTTP is authorized/regulated under WDR No. R9-2008-0096. The Discharger states in the ROWD for this permit, "MCBCP [Marine Corps Base, Camp Pendleton] plans to recycle and reuse as much of the tertiary treated water as possible on the Base..."

Wastewater for recycling is disinfected prior to being pumped to the reuse/recycling storage locations. The reclaimed water pump station consists of three vertical turbine pumps to transfer treated water to the reclaimed water distribution and storage systems. Any off-spec water is stored in a storage tank near the SRTTP site for subsequent re-treatment. Excess treated wastewater that is not reused will not be disinfected and will either be discharged directly to the OOO under this Order, or will be pumped to the Lemon Grove Ponds for storage. Under emergency operating conditions and during start-up operations, the SRTTP will continue to discharge treated effluent to the Lemon Grove Ponds, which will then be pumped into the OOO through the Lemon Grove Pump Station.

SRTTP's treatment train consists of a mechanical bar screen (and one manual backup), two grit vortexes, alum injection, five sequencing batch reactors (SBRs), two equalization basins for the SBRs, three disk filters, and two chlorine contact basins. Chlorination will only be performed on effluent that is intended for distribution as reclaimed water.

A biofilter has been installed for odor control. Foul air from the influent pump station, the screening channels, the grit collector and the sludge processing room is routed to the biofilter to receive natural biological removal of the odors through a bed of wood chip and compost filter media.

Submersible pumps in the SBRs pump waste activated sludge from the SBRs to two aerobic digesters. Each digester is equipped with a surface aerator and a decanting mechanism to thicken the sludge. Digested sludge is pumped to two dewatering belt filter presses. A gravity belt thickener is available as a back-up for the decanters on the digesters. Dewatered solids are conveyed by a belt conveyor to a trailer and hauled to sludge drying beds for additional drying if necessary. Biosolids are hauled to an approved landfill off Base.

The SRTTP has a certified daily average flow capacity of 5 MGD (with daily peaks of 10 MGD). However capacity limitations for discharges through the OOO currently limit the

discharge of wastewater from Camp Pendleton to the Pacific Ocean through the OOO to 3.6 MGD.

**B. Discharge Points and Receiving Waters**

The City of Oceanside owns and operates the OOO which begins at the City of Oceanside’s La Salina Wastewater Treatment Plant site just north of the mouth of Loma Alta Creek and extends southwesterly approximately 8,850 ft offshore to a depth of approximately 100 ft. The OOO is a 38-inch steel pipe with a 1-inch thick cement mortar interior lining and 2.75-inch thick cement mortar outer jacket; the OOO has a 36-inch internal diameter.

The OOO terminates with a 230-ft diffuser collinear with the rest of the outfall and extends to a depth of approximately 108 ft. The diffuser has fourteen 5-inch diameter ports and ten 4-inch diameter ports. The terminus of the diffuser is located at Latitude 33° 09' 46" North, Longitude 117° 23' 29" West.

The design capacity of the OOO is 30 MGD (average daily flow), with a maximum rated peak capacity of 45 MGD. The City of Oceanside may discharge up to 22.9 MGD through the OOO subject to waste discharge requirements contained in Order No. R9-2005-0136 (NPDES Permit No. CA0109347) which was adopted by the Regional Water Board on August 10, 2005. The Fallbrook Public Utility District has a contract with the City of Oceanside for the discharge of up to 2.4 MGD of tertiary-treated effluent to the Pacific Ocean through the OOO, subject to waste discharge requirements of Order No. R9-2006-0002 (NPDES Permit No. CA0108031). Genentech, Inc. has a contract with the City of Oceanside for the discharge of up to 0.155 MGD of brine and other wastes associated with water softening and purification processes and other non-industrial maintenance-type activities to the Pacific Ocean through the OOO, subject to waste discharge requirements contained in Order No. R9-2003-0140 (NPDES Permit No. CA0109193) which was adopted by the Regional Water Board on August 13, 2003. The Marine Corps Base, Camp Pendleton currently has a contract with the City of Oceanside for the discharge of up to 3.6 MGD of undisinfected secondary effluent to the Pacific Ocean through the OOO.

**Table F-2. Dischargers to OOO**

Discharger (Order)	Discharging Facility	Nature of Discharge	Flow (MGD)
City of Oceanside (Order No. R9-2002-0136)	La Salina WWTP	Secondary treated effluent	5.5
	San Luis Rey WWTP	Secondary treated effluent	15.4
	Brackish Groundwater Desalination Facility	Reverse Osmosis Brine	2.0
Fallbrook Public Utility District (Order No. R9-2006-0002)	Plant No. 1	Tertiary treated effluent	2.4
USMC Camp Pendleton (Order No. R9-2008-0096)	Plant Nos. 1, 2, 3, and 13 (Now includes SRTTP)	Secondary treated effluent	3.6
Genentech, Inc (Order No. R9-2003-0140)	Genentech NIMO Facility	Brine waste discharge from water purification	0.155

Discharger (Order)	Discharging Facility	Nature of Discharge	Flow (MGD)
		and softening processes	
<b>TOTAL</b>			<b>29.055</b>

The combined permitted flow rate from all agencies discharging through the OOO, including the discharge from the Facility, is 29.055 MGD. The Regional Water Board, with assistance from the State Water Board, determined the minimum initial dilution factor to be 87 for the discharge of up to 29.055 MGD of effluent through the OOO using the USEPA-approved computer modeling package Visual Plumes with the UM3 model. The computer modeling was performed based on characteristics of the OOO, the effluent, and the receiving water, subject to the input limitations of Visual Plumes. Initial dilution factors were determined for each month during the period July 2003 through June 2004 using receiving water characteristics for each month provided by the City of Oceanside; the minimum initial dilution factor was determined using the May 2004 receiving water data. Additional data and information regarding the calculation of the initial dilution provided by the OOO is available in the City of Oceanside file (Order No. R9-2005-0136) at the Regional Water Board and is available for review upon request.

Oceanside Artificial Fishing Reef No. 1, described in the California Department of Fish and Game Guide to Artificial Reefs of Southern California, is located approximately 6,000 feet north of the inshore end of the OOO diffuser at Latitude 33°10' 57" North, Longitude 117°25' 00" West. Additionally, the North Carlsbad and Agua Hedionda kelp beds are the closest significant kelp beds to the Oceanside Ocean Outfall.

**C. Summary of Existing Requirements and Self-Monitoring Report (SMR) Data**

Effluent limitations contained in the existing Order for discharges from Discharge Point No. 001 through the OOO (Monitoring Location EFF-001) and representative monitoring data from the term of the previous Order for SRTTP are as follows:

**Table F-3a. Historic Effluent Limitations and Monitoring Data (BOD<sub>5</sub> and TSS)**

Parameter	Unit	Effluent Limitations			Monitoring Data <sup>1</sup>		
		Monthly Average	Weekly Average	Maximum at any time	Highest Monthly Average	Highest Weekly Average	Highest Maximum at any time
Biochemical Oxygen Demand 5-day @ 20°C (BOD <sub>5</sub> )	mg/L	30	45	--	23.75	27	--
Total Suspended Solids (TSS)	mg/L	30	45	--	5.1875	11.2	--

<sup>1</sup> Monitoring data for the year 2007 from the SRTTP

**Table F-3b. Historic Effluent Limitations and Monitoring Data (Ocean Plan Parameters – Table A)**

Parameter	Units	Effluent Limitations			Monitoring Data <sup>1</sup>		
		Monthly Average	Weekly Average	Maximum at any time	Highest Monthly Average	Highest Weekly Average	Highest Maximum at any time
Oil and Grease	mg/L	25	40	75	--	--	--
Settleable Solids <sup>2</sup>	ml/L	1.0	1.5	3.0	0.1795	0.54	2.5
Turbidity <sup>2</sup>	NTU	75	100	225	995.40	4965	4965
pH	pH units	--	--	6.0 – 9.0	--	--	7.2 – 7.6

<sup>1</sup> Monitoring data for the year 2007 from the SRTTP

<sup>2</sup> Monitoring data for settleable solids and turbidity were not available for the SRTTP. Data summarized for settleable solids and turbidity in this table are for the total combined effluent flow of Treatment Plant Nos. 1, 2, 3 and the SRTTP through the OOO for the year 2007 (since the SRTTP has been on-line).

**Table F-3c. Historic Effluent Limitations and Monitoring Data (Ocean Plan Parameters – Table B, for Protection of Aquatic Life)**

Parameter	Units	Effluent Limitation			Monitoring Data (SRTTP for 2007)		
		6-Month Median	Daily Maximum	Instantaneous Maximum	Highest 6-Month Median	Highest Daily Maximum	Highest Instantaneous Maximum
Arsenic	µg/L	410	2,400	6,200	1.99	2.58	2.58
Cadmium	µg/L	81	320	810	<1.11	<1.11	<1.11
Chromium (Hexavalent)	µg/L	160	650	1,600	<0.200	<0.200	<0.200
Copper	µg/L	83	810	2,300	46.5	54.6	54.6
Lead	µg/L	160	650	1,600	5.07	6.04	6.04
Mercury	µg/L	3.2	13	32	<0.20	<0.20	<0.20
Nickel	µg/L	410	1,600	4,100	2.69	3.42	3.42
Selenium	µg/L	1,200	4,900	12,000	2.34	3.46	3.46
Silver	µg/L	44	210	550	<1.11	<1.11	<1.11
Zinc	µg/L	980	5,800	16,000	182.0	220.0	220.0
Cyanide	µg/L	81	320	810	<10	<10	<10
Total Chlorine Residual	µg/L	162	650	4,900	50	1133 (3/4/07)	1133
Ammonia (as N)	µg/L	49,000	190,000	490,000	6690	10300	10300
Chronic Toxicity	TUc	--	81	--	--	40	--
Phenolic Compounds (non-chlorinated)	µg/L	2,400	9,700	24,000	<26	<26	<26
Chlorinated Phenolics	µg/L	81	320	810	<26	<26	<26
Endosulfan	µg/L	0.73	1.5	2.2	<0.016	<0.016	<0.016
Endrin	µg/L	0.16	0.32	0.49	<0.011	<0.011	<0.011
HCH	µg/L	0.32	0.65	0.97	<0.005	<0.005	<0.005
Radioactivity	pci/l	<sup>1</sup>			--	--	--

<sup>1</sup> Not to exceed limits specified in Title 17, Division 1, Chapter 5, Subchapter 4, Group 3, Article 3, Section 30253 of the California Code of Regulations. Reference to Section 30253 is prospective, including future changes to any incorporated provisions of federal law, as the changes take effect.

**Table F-3d. Historic Effluent Limitations and Monitoring Data (Ocean Plan Parameters – Table B, for Protection of Human Health)**

Parameter	Units	Effluent Limitation	Monitoring Data (From Jan 2002 To Dec 2007)	
		Average Monthly	Highest Average Monthly Discharge	Highest Daily Discharge
Acrolein	µg/L	18,000	<20	<20
Antimony	µg/L	97,000	<1.11	<1.11
Bis(2-chloroethoxy)methane	µg/L	360	<15.4	<15.4
Bis(2-chloroisopropyl)ether	µg/L	97,000	<15.4	<15.4
Chlorobenzene	µg/L	46,000	<2.0	<2.0
Chromium (III)	µg/L	15,000,000	<1.11	<1.11
Di-n-butyl phthalate	µg/L	280,000	<15.4	<15.4
Dichlorobenzenes	µg/L	410,000	<2.0	<2.0
Diethyl phthalate	µg/L	2,700,000	<15.4	<15.4
Dimethyl Phthalate	µg/L	66,000,000	<15.4	<15.4
4,6-Dinitro-2-methylphenol	µg/L	18,000	<15.4	<15.4
2,4-Dinitrophenol	µg/L	320	<38.5	<38.5
Ethylbenzene	µg/L	330,000	<2.0	<2.0
Fluoranthene	µg/L	1,200	<15.4	<15.4
Hexachlorocyclopentadiene	µg/L	4,700	<15.4	<15.4
Nitrobenzene	µg/L	400	<15.4	<15.4
Thallium	µg/L	160	<1.11	<1.11
Toluene	µg/L	6,900,000	<2.0	<2.0
Tributyltin	µg/L	0.11	<0.005	<0.005
1,1,1-Trichloroethane	µg/L	44,000,000	<2.0	<2.0
Acrylonitrile	µg/L	8.1	<10	<10
Aldrin	µg/L	0.0018	<0.005	<0.005
Benzene	µg/L	480	<2.0	<2.0
Benzidine	µg/L	0.0056	<38.5	<38.5
Beryllium	µg/L	2.7	<1.11	<1.11
Bis(2-chloroethyl)ether	µg/L	3.7	<15.4	<15.4
Bis(2-ethylhexyl)phthalate	µg/L	280	<15.4	<15.4
Carbon tetrachloride	µg/L	73	<2.0	<2.0
Chlordane	µg/L	0.0019	<0.022	<0.022
Chlorodibromomethane	µg/L	700	8.85	8.85
Chloroform	µg/L	11,000	8.2	8.2
DDT	µg/L	0.014	<0.011	<0.011
1,4-Dichlorobenzene	µg/L	1,500	<2.0	<2.0
3,3'-Dichlorobenzidine	µg/L	0.66	<38.5	<38.5
1,2-Dichloroethane	µg/L	2,300	<2.0	<2.0
1,1-Dichloroethylene	µg/L	73	<2.0	<2.0
Dichlorobromomethane	µg/L	500	11.3	11.3
Dichloromethane	µg/L	36,000	<2.0	<2.0
1,3-Dichloropropene	µg/L	720	<2.0	<2.0
Dieldrin	µg/L	0.0032	<0.011	<0.011
2,4-Dinitrotoluene	µg/L	210	<15.4	<15.4
1,2-Diphenylhydrazine	µg/L	13	<15.4	<15.4
Halomethanes	µg/L	11,000	2.13	2.13
Heptachlor	µg/L	0.041	<0.005	<0.005
Heptachlor epoxide	µg/L	0.0016	<0.005	<0.005
Hexachlorobenzene	µg/L	0.017	<15.4	<15.4
Hexachlorobutadiene	µg/L	1,100	<15.4	<15.4
Hexachloroethane	µg/L	200	<15.4	<15.4
Isophorone	µg/L	59,000	<15.4	<15.4

Parameter	Units	Effluent Limitation	Monitoring Data (From Jan 2002 To Dec 2007)	
		Average Monthly	Highest Average Monthly Discharge	Highest Daily Discharge
N-nitrosodimethylamine	µg/L	590	<15.4	<15.4
N-nitrosodi-N-propylamine	µg/L	31	<15.4	<15.4
N-nitrosodiphenylamine	µg/L	200	<15.4	<15.4
PAHs	µg/L	0.71	<10.9	<10.9
PCBs	µg/L	0.0015	<0.108	<0.108
TCDD Equivalents	µg/L	0.00000032	<0.001400	<0.001400
1,1,2,2-Tetrachloroethane	µg/L	190	<2.0	<2.0
Tetrachloroethylene	µg/L	160	<2.0	<2.0
Toxaphene	µg/L	0.017	<0.100	<0.100
Trichloroethylene	µg/L	2,200	<2.0	<2.0
1,1,2-Trichloroethane	µg/L	760	<2.0	<2.0
2,4,6-Trichlorophenol	µg/L	23	<15.4	<15.4
Vinyl Chloride	µg/L	2,900	<5.0	<5.0

#### D. Compliance Summary

On March 18, 2008 a compliance evaluation inspection was conducted at the Facility. Notable “Major Findings” included in the report are summarized below:

1. Regional Water Board Order No. R9-2003-0155, Provision D.5, requires that all non-domestic facilities with the potential to discharge oil and other petroleum products, such as vehicle maintenance facilities, be equipped with an oil/water separator to handle peak hydraulic loads and to prevent plant influent from containing free oil, or oil and grease at concentrations greater than 25 mg/L (as measured using weekly influent oil and grease samples from each plant).

Influent data for November 2007, December 2007, and January 2008 were reviewed and multiple oil and grease exceedances were reported by the facility to the Regional Water Board:

2. Regional Water Board Order No. R9-2003-0155, Part (e) of Attachment 3, Standard Provisions, states the permittee shall at all times properly operate and maintain all facilities and systems of treatment and control (and related appurtenances) which are installed or used by the permittee to achieve compliance with the conditions of this permit.

The inspection report states, “The previous inspection report stated that a review of O&M logs for the treatment plants indicated various semi-annual preventative maintenance (PM) activities were performed late and less frequently than required. The same observation was made during this most recent inspection, however the Base appears to continue to make significant progress addressing this issue, with much less preventative maintenance activities being missed or not recorded than last year, which was significantly better than the year before that.

Overall the Discharger appears to be completing the majority of preventative maintenance for the WWTPs on time; however some of the quarterly, semi-annual, and annual PM activities appear to be behind schedule.”

3. Regional Water Board Order No. R9-2003-0155, Provision D.5.b, states that "All oil/water separators serving active facilities shall be visually inspected once per week to insure proper operation and removal of accumulated oil. The inspection may be performed by facility personnel or other responsible agency. A signed written log shall be kept documenting each inspection..."

The inspection report states, “The Source Control Program Quarterly Report for November 2007 through January 2008 was reviewed as a component of the inspection. The report stated that various oil/water separators have been identified as not being inspected on a weekly basis or maintaining an up-to-date log book as specified in the Order.

The following oil/water separators were cited in the report as being out of compliance:

13053, 13079 (also cited in previous inspection report), 32862 (also cited in previous inspection report), 330545, 2642 (also cited in previous inspection report), 53670, and 63244.

The Discharger reported that the Environmental Security Branch, which oversees the log books, is continuing to address deficiencies associated with the proper maintenance of oil/water separator log books.”

#### **E. Planned Changes – Not Applicable**

### **III. APPLICABLE PLANS, POLICIES, AND REGULATIONS**

The requirements contained in the proposed Order are based on the requirements and authorities described in this section.

#### **A. Legal Authorities**

This Order is issued pursuant to section 402 of the federal Clean Water Act (CWA) and implementing regulations adopted by the U.S. Environmental Protection Agency (USEPA) and chapter 5.5, division 7 of the California Water Code (commencing with section 13370). It shall serve as a NPDES permit for point source discharges from this facility to surface waters. This Order also serves as Waste Discharge Requirements (WDRs) pursuant to article 4, chapter 4, division 7 of the Water Code (commencing with section 13260).

#### **B. California Environmental Quality Act (CEQA)**

Under Water Code section 13389, this action to adopt an NPDES permit is exempt from the provisions of CEQA, Public Resources Code sections 21100 through 21177.



**C. State and Federal Regulations, Policies, and Plans**

**1. Water Quality Control Plans.** The Regional Water Quality Control Board (Regional Water Board) adopted a Water Quality Control Plan for the San Diego Basin (hereinafter Basin Plan) on September 8, 1994 that designates beneficial uses, establishes water quality objectives, and contains implementation programs and policies to achieve those objectives for the Pacific Ocean. The Basin Plan was subsequently approved by the State Water Resources Control Board (State Water Board) on December 13, 1994. Subsequent revisions to the Basin Plan have also been adopted by the Regional Water Board and approved by the State Water Board. The Basin Plan designates beneficial uses, establishes water quality objectives, and contains implementation programs and policies to achieve those objectives for all waters addressed through the plan. Beneficial uses applicable to the Pacific Ocean are as follows:

**Table F-4. Basin Plan Beneficial Uses**

Discharge Point	Receiving Water Name	Beneficial Use(s)
001	Pacific Ocean	Industrial service supply; navigation; contact water recreation; non-contact water recreation; commercial and sport fishing; preservation of biological habitats of special significance; wildlife habitat; rare, threatened, or endangered species; marine habitat; aquaculture; migration of aquatic organisms; spawning, reproduction, and/or early development; shellfish harvesting

Requirements of this Order implement the Basin Plan.

**2. California Ocean Plan.** The State Water Board adopted the *Water Quality Control Plan for Ocean Waters of California, California Ocean Plan* (Ocean Plan) in 1972 and amended it in 1978, 1983, 1988, 1990, 1997, 2000, and 2005. The State Water Board adopted the latest amendment on April 21, 2005 and it became effective on February 14, 2006. The Ocean Plan is applicable, in its entirety, to point source discharges to the ocean. The Ocean Plan identifies beneficial uses of ocean waters of the State to be protected as summarized below:

**Table F-5. Ocean Plan Beneficial Uses**

Discharge Point	Receiving Water	Beneficial Uses
001	Pacific Ocean	Industrial water supply; water contact and non-contact recreation, including aesthetic enjoyment; navigation; commercial and sport fishing; mariculture; preservation and enhancement of designated Areas of Special Biological Significance (ASBS); rare and endangered species; marine habitat; fish spawning and shellfish harvesting

In order to protect the beneficial uses, the Ocean Plan establishes water quality objectives and a program of implementation. Requirements of this Order implement the Ocean Plan.

3. **Alaska Rule.** On March 30, 2000, USEPA revised its regulation that specifies when new and revised State and tribal water quality standards (WQS) become effective for CWA purposes (40 CFR § 131.21, 65 Fed. Reg. 24641 (April 27, 2000)). Under the revised regulation (also known as the Alaska rule), new and revised standards submitted to USEPA after May 30, 2000, must be approved by USEPA before being used for CWA purposes. The final rule also provides that standards already in effect and submitted to USEPA by May 30, 2000, may be used for CWA purposes, whether or not approved by USEPA.
4. **Antidegradation Policy.** Section 131.12 requires that the State water quality standards include an antidegradation policy consistent with the federal policy. The State Water Board established California's antidegradation policy in State Water Board Resolution No. 68-16. Resolution No. 68-16 incorporates the federal antidegradation policy where the federal policy applies under federal law. Resolution No. 68-16 requires that existing water quality be maintained unless degradation is justified based on specific findings. The Regional Water Board's Basin Plan implements, and incorporates by reference, both the State and federal antidegradation policies. The permitted discharge must be consistent with the antidegradation provision of section 131.12 and State Water Board Resolution No. 68-16.
5. **Anti-Backsliding Requirements.** Sections 402(o)(2) and 303(d)(4) of the CWA and federal regulations at title 40, Code of Federal Regulations<sup>1</sup> section 122.44(l) prohibit backsliding in NPDES permits. These anti-backsliding provisions require that effluent limitations in a reissued permit must be as stringent as those in the previous permit, with some exceptions in which limitations may be relaxed.

#### **D. Impaired Water Bodies on CWA 303(d) List**

On June 28, 2007, the USEPA approved the list of impaired water bodies, prepared by the State Water Board pursuant to Section 303 (d) of the CWA, which are not expected to meet applicable water quality standards after implementation of technology-based effluent limitations for point sources. The 303 (d) list includes the following sections of Pacific Ocean shoreline within the proximity of the OOO as impaired for bacteria indicators:

1. 0.49 miles of Pacific Ocean shoreline at the mouth of the San Luis Rey River
2. 1.1 miles of Pacific Ocean shoreline at the mouth of Loma Alta Creek
3. 1.2 miles of Pacific Ocean shoreline at Buena Vista Creek

Impairment has been detected at the shorelines indicated above; however, the receiving waters in the immediate vicinity of the Facility's discharge point (Discharge Point No. 001) are not included on the current 303 (d) list.

---

<sup>1</sup> All further statutory references are to title 40 of the Code of Federal Regulations unless otherwise indicated.

This permit implements receiving water objectives for bacterial indicators.

## **E. Other Plans, Policies and Regulations**

### **1. Secondary Treatment Regulations**

40 CFR 133 establishes the minimum levels of effluent quality to be achieved by secondary treatment. These limitations, established by the USEPA, are incorporated into Order No. R9-2008-0096, except where more stringent limitations are required by other applicable plans, policies, or regulations.

### **2. Storm Water**

Sewage treatment works with a design flow of 1.0 MGD or greater are required to comply with Water Quality Order No. 97-03-DWQ (NPDES General Permit No. CAS000001), WDRs for Discharger of Storm Water Associated with Industrial Activity, Excluding Construction Activities. The Discharger shall file a Notice of Intent within 60 days of adoption of this Order (unless already submitted under the previous Order) and comply with Order No. 97-03-DWQ or the Discharger shall provide certification to the Regional Water Board that all storm water is captured and treated on-site and no storm water is discharged or allowed to run off-site from the facility.

## **IV. RATIONALE FOR EFFLUENT LIMITATIONS AND DISCHARGE SPECIFICATIONS**

The CWA requires point source dischargers to control the amount of conventional, non-conventional, and toxic pollutants that are discharged into the waters of the United States. The control of pollutants discharged is established through effluent limitations and other requirements in NPDES permits. There are two principal bases for effluent limitations in the Code of Federal Regulations: section 122.44(a) requires that permits include applicable technology-based limitations and standards; and section 122.44(d) requires that permits include water quality-based effluent limitations to attain and maintain applicable numeric and narrative water quality criteria to protect the beneficial uses of the receiving water.

### **A. Discharge Prohibitions**

Discharge Prohibitions A.1 and A.2 have been carried over from Order No. R9-2003-0155 in section III of this Order. Discharge Prohibitions A.3 and A.4 in Order No. R9-2003-0155 have been combined for clarification, and limit the discharge of effluent through the OOO to 3.6 MGD, which is less than the 5 MGD rated capacity of the facility. Discharge Prohibitions A.5 and A.6 from the previous Order have been carried over as Discharge Provisions in section VI.A.2 (and Attachment G) of this Order.

## B. Technology-based Effluent Limitations

### 1. Scope and Authority

Regulations promulgated in section 125.3(a)(1) require technology-based effluent limitations for municipal dischargers to be placed in NPDES permits based on Secondary Treatment Standards or Equivalent to Secondary Treatment Standards.

### 2. Applicable Technology-based Effluent Limitations

The Federal Water Pollution Control Act Amendments of 1972 (PL 92-500) established the minimum performance requirements for POTWs [defined in section 304(d)(1)]. Section 301(b)(1)(B) of that Act requires that such treatment works must, as a minimum, meet effluent limitations based on secondary treatment as defined by the USEPA Administrator.

Based on this statutory requirement, USEPA developed secondary treatment regulations, which are specified in Part 133. These technology-based regulations apply to all municipal wastewater treatment plants and identify the minimum level of effluent quality attainable by secondary treatment in terms of biochemical oxygen demand (BOD<sub>5</sub>), total suspended solids (TSS), and pH.

**Table F-6. Summary of Technology-based Effluent Limitations for Secondary Treatment Facilities Established by USEPA at 40 CFR 133.102**

Parameter	Monthly Average	Weekly Average	30-day Percent Removal
Biochemical Oxygen Demand (5-day @ 20 °F) (BOD <sub>5</sub> )	30 mg/L	45 mg/L	85%
Total Suspended Solids	30 mg/L	45 mg/L	85%
pH	6.0 to 9.0		

Table A of the California Ocean Plan establishes technology based effluent limitations for publicly owned treatment works which discharge into the ocean waters of the State and outside the territorial waters of the State which may affect the quality of the ocean waters of the State. Table A requirements are summarized below:

**Table F-7. Summary of Technology-based Effluent Limitations from Table A of the Ocean Plan**

Parameter	Unit	Average Monthly	Average Weekly	Instantaneous Maximum
Grease and Oil	mg/L	25	40	75
Suspended Solids <sup>1,2</sup>	mg/L	--	--	--
Settleable Solids	ml/L	1.0	1.5	3.0
Turbidity	NTU	75	100	225
pH	standard units	--	--	<sup>3</sup>

Dischargers shall, as a 30-day average, remove 75 percent of suspended solids from the influent stream before discharging wastewaters to the ocean, except that the effluent limitation to be met shall not be lower than 69 mg/L.

- <sup>2</sup> Includes a minimum percent removal of 75 percent, applicable to POTWs.  
<sup>3</sup> Within limit of 6.0 to 9.0 at all times.

In addition to the technology-based effluent limitations discussed above, Provision D.5.a of Order No. R9-2003-0155 requires the Discharger to reduce influent concentrations of oil and grease to 25 mg/L for each treatment plant, to be controlled by the use of oil and water separators at all non-domestic facilities with the potential to discharge oil and other petroleum products. The Discharger has chronically exceeded this concentration over the term of the previous Order. The Discharger argues that the influent oil and grease limit of 25 mg/L cannot be reliably met in an influent stream receiving wastes from domestic (i.e., residential units) sources, and that oil and grease concentrations in untreated domestic wastewater typically range from 50 to 100 mg/L (*Metcalf and Eddy, Wastewater Engineering, 3<sup>rd</sup> ed., New York; McGraw-Hill, Inc., 1991*). The Regional Water Board Staff agrees that 25 mg/L is typically lower than what is commonly observed in domestic influent. Further, the Discharger's influent concentrations of oil and grease are typical of most domestic influent.

In addition, this influent concentration of 25 mg/L is less than the weekly average effluent limitation for the final effluent (40 mg/L) and instantaneous maximum effluent limitation of 75 mg/L. Thus, this influent requirement is more stringent than the technology-based effluent limitations established by the Ocean Plan.

Data for oil and grease do not indicate a correlation of effluent exceedances when influent concentrations of oil and grease are greater than 25 mg/L. In addition, historically the influent concentrations of oil and grease, which have been over 25 mg/L, have not, and are not expected to negatively impact the operations of the SRTTP. The Discharger has submitted signed statements by the engineers and contractors who designed and built and currently operate the SRTTP which states that with the continuation of the source control program to keep the influent oil and grease levels within the historical ranges, the performance of the SRTTP should not be adversely impacted.

With the continuation of the source control program, Standard Provision I.D of Attachment D (Proper Operation and Maintenance), and the continued application of the final technology based effluent limitations for oil and grease, the Regional Water Board does not believe the influent requirement for oil and grease is necessary or anymore protective of water quality. Thus, the influent requirement for oil and grease has been removed. The removal of the oil and grease influent requirement is not expected to adversely impact the receiving water.

The Regional Water Board reserves the right to reopen and revise this permit if increased oil and grease concentrations are correlated to adverse impacts to the operation and treatment ability of the SRTTP.

## C. Water Quality-based Effluent Limitations (WQBELs)

### 1. Scope and Authority

Section 301(b) of the CWA and section 122.44(d) require that permits include limitations more stringent than applicable federal technology-based requirements where necessary to achieve applicable water quality standards.

Section 122.44(d)(1)(i) mandates that permits include effluent limitations for all pollutants that are or may be discharged at levels that have the reasonable potential to cause or contribute to an exceedance of a water quality standard, including numeric and narrative objectives within a standard. Where reasonable potential has been established for a pollutant, but there is no numeric criterion or objective for the pollutant, water quality-based effluent limitations (WQBELs) must be established using: (1) USEPA criteria guidance under CWA section 304(a), supplemented where necessary by other relevant information; (2) an indicator parameter for the pollutant of concern; or (3) a calculated numeric water quality criterion, such as a proposed State criterion or policy interpreting the State's narrative criterion, supplemented with other relevant information, as provided in section 122.44(d)(1)(vi).

The process for determining reasonable potential and calculating WQBELs when necessary is intended to protect the designated uses of the receiving water as specified in the Basin Plan and Ocean Plan, and achieve applicable water quality objectives and criteria that are contained in the Ocean Plan.

### 2. Applicable Beneficial Uses and Water Quality Criteria and Objectives

The Basin Plan and Ocean Plan designates beneficial uses, establishes water quality objectives, and contain implementation programs and policies to achieve those objectives for all waters.

- a. Basin Plan. The beneficial uses specified in the Basin Plan applicable to the Pacific Ocean are summarized in section III.C.1 of this Fact Sheet. The Basin Plan includes water quality objectives for dissolved oxygen and pH applicable to the receiving water.

The Basin Plan states, "The terms and conditions of the State Board's *"Water Quality Control Plan for Ocean Waters of California"* (Ocean Plan), *"Water Quality Control Plan for Control of Temperature in the Coastal and Interstate Waters and Enclosed Bays and Estuaries of California"* (Thermal Plan), and any revisions thereto are incorporated into this Basin Plan by reference. The terms and conditions of the Ocean Plan and Thermal Plan apply to the ocean waters within this Region."

- b. Ocean Plan. The beneficial uses specified in the Ocean Plan for the Pacific Ocean are summarized in section III.C.2 of this Fact Sheet. The Ocean Plan also includes water quality objectives for the ocean receiving water for bacterial

characteristics, physical characteristics, chemical characteristics, biological characteristics, and radioactivity.

Table B of the Ocean Plan includes the following water quality objectives for toxic pollutants and whole effluent toxicity:

- i. 6-month median, daily maximum, and instantaneous maximum objectives for 21 chemicals and chemical characteristics, including total residual chlorine and chronic toxicity, for the protection of marine aquatic life.
- ii. 30-day average objectives for 20 non-carcinogenic chemicals for the protection of human health.
- iii. 30-day average objectives for 42 carcinogenic chemicals for the protection of human health.
- iv. Daily maximum objectives for acute and chronic toxicity.

### **3. Determining the Need for WQBELs**

Order No. R9-2003-0155 contained effluent limitations for non-conventional and toxic pollutant parameters in Table B of the 1997 California Ocean Plan. For Order No. R9-2008-0096, the need for effluent limitations based on water quality objectives in Table B of the Ocean Plan was re-evaluated in accordance with 40 CFR 122.44(d) and guidance for statistically determining the “reasonable potential” for a discharged pollutant to exceed an objective, as outlined in the revised Technical Support Document for Water Quality-based Toxics Control (TSD; EPA/505/2-90-001, 1991) and the Ocean Plan Reasonable Potential Analysis (RPA) Amendment that was adopted by the State Water Board on April 21, 2005. The statistical approach combines knowledge of effluent variability (as estimated by a coefficient of variation) with the uncertainty due to a limited amount of effluent data to estimate a maximum effluent value at a high level of confidence. This estimated maximum effluent value is based on a lognormal distribution of daily effluent values. Projected receiving water values (based on the estimated maximum effluent value or the reported maximum effluent value and minimum probable initial dilution), can then be compared to the appropriate objective to determine that potential for an exceedance of that objective and the need for an effluent limitation. According to the Ocean Plan amendment, the RPA can yield three endpoints: 1) Endpoint 1, an effluent limitation is required and monitoring is required; 2) Endpoint 2, an effluent limitation is not required and the Regional Water Board may require monitoring; 3) Endpoint 3, the RPA is inconclusive, monitoring is required, and an existing effluent limitation may be retained or a permit reopener clause may be included to allow inclusion of an effluent limitation if future monitoring warrants the inclusion. Endpoint 3 is typically the result when there are fewer than 16 data points and all are censored data (i.e., below quantitation or method detection levels for an analytical procedure). If no data was provided for a parameter, and a RPA could not be conducted for that parameter, reasonable potential for that parameter was carried over to this Order

based on the requirements of federal and State anti-backsliding regulations. Data for all parameters was available to conduct an RPA.

Before establishing a dilution credit for a discharge, it must first be determined if, and how much, receiving water is available to dilute the discharge. Prior to issuance of Order No. 2000-011 (City of Oceanside San Luis Rey and La Salina Wastewater Treatment Plants), the State Water Board had determined the minimum initial dilution factor (Dm), for the OOO to be 82 to 1. This determination was based on 24 diffuser ports being open and a flow rate of 21.3 MGD although, at the time, the total permitted flow rate through the OOO was only 20.9 MGD. When USMC Camp Pendleton and Biogen IDEC Pharmaceuticals Corporation (now Genentech, Inc.) applied for NPDES permits to discharge through the OOO in 2003, the dilution factor was recalculated by the State Water Board and was found not significantly different from the previous Dm. Based on the 2003 calculation, Order No. R9-2003-0140 included a Dm of 80 based on those calculations. In 2005, the initial dilution factor, Dm, for the OOO was again recalculated for Order No. R9-2005-0136 (City of Oceanside San Luis Rey and La Salina Wastewater Treatment Plants) in order to account for the expansion of the City of Oceanside’s San Luis Rey Wastewater Treatment Plant and the addition of discharges from USMC Camp Pendleton and the Genentech facility. The new recalculated Dm was determined as 87:1 using the USEPA approved computer modeling application Visual Plumes with the UM3 model. The most recently established Dm of 87:1, which was determined for the OOO in 2005, is applied to the water quality based effluent limitations established in this Order.

Conventional pollutants were not a part of the reasonable potential analysis. Effluent limitations for these pollutants are included in this Order as described in section IV.B., above.

Effluent data provided in the Discharger’s monitoring reports for the SRTTP in 2007 were used in the analyses. A minimum probable initial dilution of 87:1 was considered in this evaluation.

A summary of the RPA results is provided below:

**Table F-8. RPA Results Summary**

Parameter (µg/L)	n <sup>1</sup>	MEC <sup>2</sup>	Most Stringent Criteria	Background	RPA End Point <sup>8</sup>
Arsenic	4	2.58	8 <sup>3</sup>	3 <sup>6</sup>	3
Cadmium	4	<1.11	1 <sup>3</sup>	0	3
Chromium (VI)	4	<0.2	2 <sup>3</sup>	0	3
Copper	4	54.6	3 <sup>3</sup>	2	1
Lead	4	6.04	2 <sup>3</sup>	0	2
Mercury	4	<0.2	0.004 <sup>3</sup>	0.0005 <sup>6</sup>	3
Nickel	4	3.42	5 <sup>3</sup>	0	2
Selenium	4	3.46	15 <sup>3</sup>	0	3
Silver	4	<1.11	0.7 <sup>3</sup>	0.16 <sup>6</sup>	3
Zinc	4	220	20 <sup>3</sup>	8 <sup>6</sup>	2
Cyanide	4	<10	1 <sup>3</sup>	0	3



Parameter (µg/L)	n <sup>1</sup>	MEC <sup>2</sup>	Most Stringent Criteria	Background	RPA End Point <sup>8</sup>
Total Residual Chlorine	358	1,133	2 <sup>3</sup>	0	1
Ammonia	12	5,575	600 <sup>3</sup>	0	2
Acute Toxicity	12	1.64	0.3 <sup>4</sup>	0	2
Chronic Toxicity	12	40	1 <sup>4</sup>	0	3
Phenolic Compounds	4	<26	30	0	3
Chlorinated Phenolics	4	<0.15	1	0	3
Endosulfan	4	<0.016	9 <sup>3</sup>	0	3
Endrin	4	<0.011	0.002 <sup>3</sup>	0	3
HCH	1	<0.005	4 <sup>3</sup>	0	3
Radioactivity (pCi/L)	4	11.99	220 <sup>5</sup>	0	7
Acrolein	2	<20	1,200 <sup>5</sup>	0	3
Antimony	2	<1.11	4.4 <sup>5</sup>	0	3
Bis(2-chloroethoxy)methane	2	<15.4	1,200 <sup>5</sup>	0	3
Bis(2-chloroisopropyl)ether	2	<15.4	570 <sup>5</sup>	0	3
Chlorobenzene	2	<2	190,000 <sup>5</sup>	0	3
Chromium (III)	2	<1.11	3,500 <sup>5</sup>	0	3
Di-n-butyl phthalate	2	<15.4	5,100 <sup>5</sup>	0	3
Dichlorobenzenes	2	<2	33,000 <sup>5</sup>	0	3
Diethyl phthalate	2	<15.4	820,000 <sup>5</sup>	0	3
Dimethyl phthalate	2	<15.4	220 <sup>5</sup>	0	3
4,6-Dinitro-2-methylphenol	6	<15.4	4 <sup>5</sup>	0	3
2,4-Dinitrophenol	6	<38.5	4,100 <sup>5</sup>	0	3
Ethylbenzene	2	<2	15	0	3
Fluoranthene	2	<15.4	8 <sup>3</sup>	0	3
Hexachlorocyclopentadiene	2	<15.4	58	0	3
Nitrobenzene	2	<15.4	4.9 <sup>5</sup>	0	3
Thallium	2	<1.11	2 <sup>5</sup>	0	3
Toluene	2	<2	85,000 <sup>5</sup>	0	3
Tributyltin	2	<0.005	0.0014 <sup>5</sup>	0	3
1,1,1-Trichloroethane	2	<2	540,000 <sup>5</sup>	0	3
Acrylonitrile	2	<10	0.1 <sup>5</sup>	0	3
Aldrin	2	<0.005	0.000022 <sup>5</sup>	0	3
Benzene	2	<2	5.9 <sup>5</sup>	0	3
Benzidine	2	<38.5	0.000069 <sup>5</sup>	0	3
Beryllium	2	<1.11	0.033 <sup>5</sup>	0	3
Bis(2-chloroethyl) Ether	2	<15.4	0.045 <sup>5</sup>	0	3
Bis(2-ethylhexyl) phthalate	2	<15.4	3.5 <sup>5</sup>	0	3
Carbon tetrachloride	2	<2	0.9 <sup>5</sup>	0	3
Chlordane	1	<0.022	0.000023 <sup>5</sup>	0	3
Chlorodibromomethane	2	8.85	8.6 <sup>5</sup>	0	3
Chloroform	2	8.2	130 <sup>5</sup>	0	3
DDT	1	<0.011	0.00017 <sup>5</sup>	0	3
1,4-Dichlorobenzene	2	<2	18 <sup>5</sup>	0	3
3,3-Dichlorobenzidine	2	<38.5	0.0081 <sup>5</sup>	0	3
1,2-Dichloroethane	2	<2	28 <sup>5</sup>	0	3
1,1-Dichloroethylene	2	<2	0.9 <sup>5</sup>	0	3
Dichlorobromomethane	2	11.3	6.2 <sup>5</sup>	0	3
Dichloromethane	2	<2	450 <sup>5</sup>	0	3
1,3-Dichloropropene	2	<2	8.9 <sup>5</sup>	0	3
Dieldrin	2	<0.011	0.00004 <sup>5</sup>	0	3
2,4-Dinitrotoluene	6	<15.4	2.6 <sup>5</sup>	0	3

Parameter (µg/L)	n <sup>1</sup>	MEC <sup>2</sup>	Most Stringent Criteria	Background	RPA End Point <sup>8</sup>
1,2-Diphenylhydrazine	2	<15.4	0.16 <sup>5</sup>	0	3
Halomethanes	1	2.13	130 <sup>5</sup>	0	3
Heptachlor	2	<0.005	0.00005 <sup>5</sup>	0	3
Heptachlor Epoxide	2	<0.005	0.00002 <sup>5</sup>	0	3
Hexachlorobenzene	2	<15.4	0.00021 <sup>5</sup>	0	3
Hexachlorobutadiene	2	<15.4	14 <sup>5</sup>	0	3
Hexachloroethane	2	<15.4	2.5 <sup>5</sup>	0	3
Isophorone	2	<15.4	730 <sup>5</sup>	0	3
N-nitrosodimethylamine	2	<15.4	7.3 <sup>5</sup>	0	3
N-nitrosodi-N-propylamine	2	<15.4	0.38 <sup>5</sup>	0	3
N-nitrosodiphenylamine	2	<15.4	2.5 <sup>5</sup>	0	3
PAHs	1	<10.9	0.0088 <sup>5</sup>	0	3
PCBs	1	<0.108	0.000019 <sup>5</sup>	0	3
TCDD equivalents (pg/L)	2	<1,400	0.0039 <sup>5</sup>	0	3
1,1,2,2-Tetrachloroethane	2	<2	2.3 <sup>5</sup>	0	3
Tetrachloroethylene	2	<2	2 <sup>5</sup>	0	3
Toxaphene	2	<0.1	0.00021 <sup>5</sup>	0	3
Trichloroethylene	2	<2	27 <sup>5</sup>	0	3
1,1,2-Trichloroethane	2	<2	9.4 <sup>5</sup>	0	3
2,4,6-Trichlorophenol	6	<15.4	0.29 <sup>5</sup>	0	3
Vinyl Chloride	2	<5	36 <sup>5</sup>	0	3

<sup>1</sup> Number of data points available for the RPA.

<sup>2</sup> If there is a detected value, the highest reported value is summarized in the table. If there are no detected values, the lowest MDL is summarized in the table.

<sup>3</sup> Based on the 6-Month Median in the Table B of the Ocean Plan

<sup>4</sup> Based on the Daily Maximum in Table B of the Ocean Plan

<sup>5</sup> Based on 30-Day Average in Table B of the Ocean Plan

<sup>6</sup> Background concentrations contained in Table C of the Ocean Plan

<sup>7</sup> Not to exceed limits specified in Title 17, Division 1, Chapter 5, Subchapter 4, Group 3, Article 3, Section 30253 of the California Code of Regulations. Radiation at levels that exceed the applicable criteria are not expected in the discharge.

<sup>8</sup> End Point 1 – RP determined, limit required, monitoring required

End Point 2 – Discharger determined not to have RP, monitoring may be established.

End Point 3 – RPA was inconclusive, carry over previous limits if applicable, establish monitoring.

Effluent limitations from Order No. R9-2003-0155 are not retained for constituents for which RPA results indicated Endpoint 2 and Endpoint 3: instead performance goals have been assigned for these constituents. Parameters for which Endpoint 2 was concluded are determined not to have reasonable potential, thus it is inappropriate to establish effluent limitations for these parameters. For parameters for which Endpoint 3 was concluded, reasonable potential was not determined. However, the RPA results are inconclusive. Because all Table B parameters were established as effluent limitations, without the use of a RPA during the previous permit renewal, these effluent limitations appear to be based on the blanket assignment of water quality objectives as effluent limitations. The practice of assigning all water quality objectives as effluent limitations was a main factor for the 2005 Ocean Plan revision to include procedures for an RPA, to eliminate unnecessary burden on the Dischargers and to establish a more equitable

procedure that would be protective of water quality objectives. Thus, parameters for which new data is available, and reasonable potential can not be determined, effluent limitations have been removed and performance goals have been established in their place. The monitoring and reporting program (MRP) for this Order is designed to obtain additional information for these constituents to determine if reasonable potential exists for these constituents in future permit renewals and/or updates.

Reasonable Potential (Endpoint 1) to exceed water quality objectives contained within the Ocean Plan was determined for copper and total residual chlorine, thus effluent limitations for copper and total residual chlorine have been established in Order No. R9-2008-0096 based on the revised initial dilution of 87, as discussed below. In addition, because only one year of data was available for the SRTTP to conduct the RPA, and numerous parameters resulted in End Point 3 (could not conclusively determine that no reasonable potential exists), reasonable potential for chronic toxicity is being carried over from the previous Order to account for any synergistic effects in the effluent that might not be apparent in the limited effluent data.

#### 4. WQBEL Calculations

- a. From the Table B water quality objectives of the Ocean Plan, effluent limitations and performance goals are calculated according to the following equation for all pollutants, except for acute toxicity (if applicable) and radioactivity:

$C_e = C_o + D_m (C_o - C_s)$  where,

$C_e$  = the effluent limitation ( $\mu\text{g/L}$ )

$C_o$  = the water quality objective to be met at the completion of initial dilution ( $\mu\text{g/L}$ )

$C_s$  = background seawater concentration

$D_m$  = minimum probably initial dilution expressed as parts seawater per part wastewater

The performance goal for acute toxicity is calculated according to the following equation:

$$C_e = C_o + (0.1) D_m (C_o - C_s)$$

Where all variable are as indicated above. This equation applies only when  $D_m > 24$ .

The  $D_m$  is based on observed waste flow characteristics, receiving water density structure, and the assumption that no currents of sufficient strength to influence the initial dilution process flow across the discharge structure.

- b. Initial dilution ( $D_m$ ) has been determined to be 87:1 by the Regional Water Board, through the application of USEPA's dilution model, Visual Plumes.

- c. Table C of the Ocean Plan establishes background concentrations for some pollutants to be used when determining reasonable potential (represented as “Cs”). In accordance with Table B implementing procedures, Cs equals zero for all pollutants not established in Table C. The background concentrations provided in Table C are summarized below:

**Table F-9. Pollutants Having Background Concentrations**

Pollutant	Background Seawater Concentration
Arsenic	3 µg/L
Copper	2 µg/L
Mercury	0.0005 µg/L
Silver	0.16 µg/L
Zinc	8 µg/L

- d. As examples, effluent limitations for copper and residual chlorine are determined as follows:

Water quality objectives from the Ocean Plan for copper and residual chlorine are:

**Table F-10. Example Parameter Water Quality Objectives**

Pollutant	6-Month Median	Daily Maximum	Instantaneous Maximum
Copper (µg/L)	3	12	30
Total Residual Chlorine (µg/L)	2	8	60

Using the equation,  $C_e = C_o + D_m (C_o - C_s)$ , effluent limitations/performance goals are calculated as follows before rounding to two significant digits.

Copper

$$C_e = 3 + 87 (3 - 2) = 90 \text{ µg/L (6-Month Median)}$$

$$C_e = 12 + 87 (12 - 2) = 882 \text{ µg/L (Daily Maximum)}$$

$$C_e = 30 + 87 (30 - 2) = 2,466 \text{ µg/L (Instantaneous Maximum)}$$

Lead

$$C_e = 2 + 87 (2 - 0) = 176 \text{ µg/L (6-Month Median)}$$

$$C_e = 8 + 87 (8 - 0) = 704 \text{ µg/L (Daily Maximum)}$$

$$C_e = 60 + 87 (60 - 0) = 5,280 \text{ µg/L (Instantaneous Maximum)}$$

Based on the implementing procedures described above, effluent limitation and performance goals have been calculated for all Table B pollutants from the California Ocean Plan and incorporated into Order No. R9-2008-0096.

The WQBELs that are retained have been changed to reflect the revised dilution factor.

- e. Title 40 CFR 122.45(f)(1) requires effluent limitations be expressed in terms of mass, with some exceptions, and 40 CFR 122.45(f)(2) allows pollutants that are limited in terms of mass to additionally be limited in terms of other units of measurement. This Order includes effluent limitations expressed in terms of mass and concentration. In addition, pursuant to the exceptions to mass limitations provided in 40 CFR 122.45(f)(1), some effluent limitations are not expressed in terms of mass, such as pH and temperature, and when the applicable standards are expressed in terms of concentration (e.g., CTR criteria and MCLs) and mass limitations are not necessary to protect the beneficial uses of the receiving water.

Mass-based effluent limitations were calculated using the following equation:

$$Lb/day = Permitted\ Flow\ (MGD) \times Pollutant\ Concentration\ (mg/L) \times 8.34$$

- f. A summary of the WQBELs established in Order No. R9-2008-0096 is provided below:

**Summary of Water Quality-based Effluent Limitations  
Discharge Point No. 001**

**Table F-11. Summary of Water Quality-based Effluent Limitations**

Parameter	Unit	Water Quality-based Effluent Limitations <sup>1</sup>			
		6-Month Median	Maximum Daily	Instantaneous Maximum	30-Day Average
<b>BASED ON OBJECTIVES FOR PROTECTION OF MARINE AQUATIC LIFE</b>					
Chronic Toxicity <sup>2</sup>	TU <sub>c</sub>	--	<b>Error! Not a valid link.</b>	--	--
Copper, Total Recoverable	µg/L	9.00E+01	8.82E+02	2.47E+03	--
	lb/day	2.70E+00	2.65E+01	7.40E+01	--
Total Residual Chlorine	µg/L	1.76E+02	7.04E+02	5.28E+03	--
	lb/day	5.28E+00	2.11E+01	1.59E+02	--

Scientific “E” notation is used to express certain values. In scientific “E” notation, the number following the “E” indicates that position of the decimal point in the value. Negative numbers after the “E” indicate that the value is less than 1, and positive numbers after the “E” indicate that the value is greater than 1. In this notation a value of 6.1E-02 represents 6.1 x 10<sup>-2</sup> or 0.061, 6.1E+02 represents 6.1 x 10<sup>2</sup> or 610, and 6.1E+00 represents 6.1 x 10<sup>0</sup> or 6.1.

<sup>2</sup> Chronic toxicity expressed as Chronic Toxicity Units (TU<sub>c</sub>) = 100/NOEL, where NOEL (No Observed Effect Level) is expressed as the maximum percent effluent or receiving water that causes no observable effect on a test organism.

- g. A summary of the performance goals is provided in Table F-14 in this Fact Sheet.

**5. Whole Effluent Toxicity (WET)**

- a. Implementing provisions at Section III.C of the Ocean Plan require chronic toxicity monitoring for ocean waste discharges with minimum an initial dilution factor below 100:1. In addition, reasonable potential has been carried over from the previous Order for chronic toxicity, thus monitoring is required. Based on methods of the California Ocean Plan, a maximum daily effluent limitation of 88 TU<sub>c</sub> is established in the Order and monthly monitoring is carried over from Order No. R9-2003-0155.
- b. Monitoring and Reporting Program No. R9-2003-0155 (MRP) established monthly monitoring requirements for acute toxicity. This requirement is carried over from the previous Order. A performance goal for acute toxicity of 26.4 TU<sub>a</sub> is established based on “Equation 2” provided in Section III.C.3.b in the Ocean Plan.

**D. Final Effluent Limitations**

The following tables list the effluent limitations established by Order No. R9-2008-0096. Where Order No. R9-2008-0096 establishes mass emission limitations, these limitations have been derived based on a flow of 3.6 MGD.

**Table F-12. Effluent Limitations Based on Secondary Treatment Standards and Table A of the Ocean Plan.**

Parameter	Unit	Effluent Limitations		
		Average Monthly	Average Weekly	Instantaneous Maximum
Biochemical Oxygen Demand (5-day @ 20 °F) (BOD <sub>5</sub> ) <sup>†</sup>	mg/L	30	45	--
TSS <sup>1</sup>	mg/L	30	45	--
Oil and Grease	mg/L	25	40	75
Settleable Solids	ml/L	1.0	1.5	3.0
Turbidity	NTU	75	100	225
pH	Standard unit	--	--	<sup>2</sup>

<sup>†</sup> The average monthly percent removal of BOD 5-day 20°C and total suspended solids shall not be less than 85 percent.

<sup>2</sup> Within limit of 6.0 to 9.0 at all times.

**Table F-13. Effluent Limitations Based on the Ocean Plan**

Parameter	Unit	Water Quality-based Effluent Limitations <sup>1</sup>			
		6-Month Median	Maximum Daily	Instantaneous Maximum	30-Day Average
<b>BASED ON OBJECTIVES FOR PROTECTION OF MARINE AQUATIC LIFE</b>					
Chronic Toxicity <sup>2</sup>	TUc	NA	145	NA	--
Copper, Total Recoverable	µg/L	9.00E+01	8.82E+02	2.47E+03	--
	lb/day	2.70E+00	2.65E+01	7.40E+01	--
Total Residual Chlorine	µg/L	1.76E+02	7.04E+02	5.28E+03	--
	lb/day	5.28E+00	2.11E+01	1.59E+02	--

<sup>1</sup> Scientific “E” notation is used to express certain values. In scientific “E” notation, the number following the “E” indicates that position of the decimal point in the value. Negative numbers after the “E” indicate that the value is less than 1, and positive numbers after the “E” indicate that the value is greater than 1. In this notation a value of 6.1E-02 represents  $6.1 \times 10^{-2}$  or 0.061, 6.1E+02 represents  $6.1 \times 10^2$  or 610, and 6.1E+00 represents  $6.1 \times 10^0$  or 6.1.

<sup>2</sup> Chronic toxicity expressed as Chronic Toxicity Units (TUc) = 100/NOEL, where NOEL (No Observed Effect Level) is expressed as the maximum percent effluent or receiving water that causes no observable effect on a test organism.

## E. Performance Goals

Constituents that do not have reasonable potential are listed as performance goals in this Order. Performance goals serve to maintain existing treatment levels and effluent quality and supports State and federal antidegradation policies. Additionally, performance goals provide all interested parties with information regarding the expected levels of pollutants in the discharge that should not be exceeded in order to maintain the water quality objectives established in the Ocean Plan. Performance goals are not limitations or standards for the regulation of the discharge. Effluent concentrations above the performance goals will not be considered as violations of the permit but serve as red flags that indicate water quality concerns. Repeated red flags may prompt the Regional Water Board to reopen and amend the permit to replace performance goals for constituents of concern with effluent limitations, or the Regional Water Board may coordinate such actions with the next permit renewal.

The following table lists the performance goals established by Order No. R9-2008-0096. A minimum probable initial dilution factor of 87 was used in establishing the performance goals.

**Table F-14. Performance Goals Based on the Ocean Plan**

Parameter	Unit	Performance Goals <sup>1</sup>			
		6-Month Median	Maximum Daily	Instantaneous Maximum	30-Day Average
<b>BASED ON OBJECTIVES FOR PROTECTION OF MARINE AQUATIC LIFE</b>					
Arsenic, Total Recoverable	µg/L	4.43E+02	2.56E+03	6.78E+03	--
	lb/day	1.33E+01	7.67E+01	2.04E+02	--
Cadmium, Total Recoverable	µg/L	8.80E+01	3.52E+02	8.80E+02	--
	lb/day	2.64E+00	1.06E+01	2.64E+01	--
Chromium VI, Total Recoverable <sup>2</sup>	µg/L	1.76E+02	7.04E+02	1.76E+03	--
	lb/day	5.28E+00	2.11E+01	5.28E+01	--
Lead, Total Recoverable	µg/L	1.76E+02	7.04E+02	1.76E+03	--
	lb/day	5.28E+00	2.11E+01	5.28E+01	--
Mercury, Total Recoverable	µg/L	3.48E+00	1.40E+01	3.52E+01	--
	lb/day	1.04E-01	4.21E-01	1.06E+00	--
Nickel, Total Recoverable	µg/L	4.40E+02	1.76E+03	4.40E+03	--
	lb/day	1.32E+01	5.28E+01	1.32E+02	--
Selenium, Total Recoverable	µg/L	1.32E+03	5.28E+03	1.32E+04	--
	lb/day	3.96E+01	1.59E+02	3.96E+02	--
Silver, Total Recoverable	µg/L	4.77E+01	2.32E+02	6.02E+02	--
	lb/day	1.43E+00	6.98E+00	1.81E+01	--
Zinc, Total Recoverable	µg/L	1.06E+03	6.34E+03	1.69E+04	--
	lb/day	3.19E+01	1.90E+02	5.08E+02	--
Cyanide, Total Recoverable <sup>3</sup>	µg/L	8.80E+01	3.52E+02	8.80E+02	--
	lb/day	2.64E+00	1.06E+01	2.64E+01	--
Ammonia (expressed as nitrogen)	µg/L	5.28E+04	2.11E+05	5.28E+05	--
	lb/day	1.59E+03	6.34E+03	1.59E+04	--
Acute Toxicity	TUa	NA	2.64E+01	NA	--
Phenolic Compounds (non-chlorinated)	µg/L	2.64E+03	1.06E+04	2.64E+04	--
	lb/day	7.93E+01	3.17E+02	7.93E+02	--
Chlorinated Phenolics	µg/L	8.80E+01	3.52E+02	8.80E+02	--
	lb/day	2.64E+00	1.06E+01	2.64E+01	--
Endosulfan <sup>11</sup>	µg/L	7.92E-01	1.58E+00	2.38E+00	--
	lb/day	2.38E-02	4.76E-02	7.13E-02	--
Endrin	µg/L	1.76E-01	3.52E-01	5.28E-01	--
	lb/day	5.28E-03	1.06E-02	1.59E-02	--
HCH <sup>4</sup>	µg/L	3.52E-01	7.04E-01	1.06E+00	--
	lb/day	1.06E-02	2.11E-02	3.17E-02	--



Parameter	Unit	Performance Goals <sup>1</sup>			
		6-Month Median	Maximum Daily	Instantaneous Maximum	30-Day Average
Radioactivity	pci/l	Not to exceed limits specified in Title 17, Division 1, Chapter 5, Subchapter 4, Group 3, Article 3, Section 30253 of the California Code of Regulations, Reference to Section 30253 is prospective, including future changes to any incorporated provisions of federal law, as the changes take effect.			
<b>OBJECTIVES FOR PROTECTION OF HUMAN HEALTH – CARCINOGENS</b>					
Acrolein	µg/L	--	--	--	1.94E+04
	lb/day	--	--	--	5.81E+02
Antimony	µg/L	--	--	--	1.06E+05
	lb/day	--	--	--	3.17E+03
Bis(2-chloroethoxy) Methane	µg/L	--	--	--	3.87E+02
	lb/day	--	--	--	1.16E+01
Bis(2-chloroisopropyl) Ether	µg/L	--	--	--	1.06E+05
	lb/day	--	--	--	3.17E+03
Chlorobenzene	µg/L	--	--	--	5.02E+04
	lb/day	--	--	--	1.51E+03
Chromium (III), Total Recoverable	µg/L	--	--	--	1.67E+07
	lb/day	--	--	--	5.02E+05
Di-n-butyl Phthalate	µg/L	--	--	--	3.08E+05
	lb/day	--	--	--	9.25E+03
Dichlorobenzenes <sup>5</sup>	µg/L	--	--	--	4.49E+05
	lb/day	--	--	--	1.35E+04
Diethyl Phthalate	µg/L	--	--	--	2.90E+06
	lb/day	--	--	--	8.72E+04
Dimethyl Phthalate	µg/L	--	--	--	7.22E+07
	lb/day	--	--	--	2.17E+06
4,6-dinitro-2-methylphenol	µg/L	--	--	--	1.94E+04
	lb/day	--	--	--	5.81E+02
2,4-dinitrophenol	µg/L	--	--	--	3.52E+02
	lb/day	--	--	--	1.06E+01
Ethylbenzene	µg/L	--	--	--	3.61E+05
	lb/day	--	--	--	1.08E+04
Fluoranthene	µg/L	--	--	--	1.32E+03
	lb/day	--	--	--	3.96E+01
Hexachlorocyclopenta diene	µg/L	--	--	--	5.10E+03
	lb/day	--	--	--	1.53E+02
Nitrobenzene	µg/L	--	--	--	4.31E+02
	lb/day	--	--	--	1.29E+01
Thallium, Total	µg/L	--	--	--	1.76E+02

Parameter	Unit	Performance Goals <sup>1</sup>			
		6-Month Median	Maximum Daily	Instantaneous Maximum	30-Day Average
Recoverable	lb/day	--	--	--	5.28E+00
Toluene	µg/L	--	--	--	7.48E+06
	lb/day	--	--	--	2.25E+05
Tributyltin	µg/L	--	--	--	1.23E-01
	lb/day	--	--	--	3.70E-03
1,1,1-trichloroethane	µg/L	--	--	--	4.75E+07
	lb/day	--	--	--	1.43E+06
<b>BASED ON OBJECTIVES FOR PROTECTION OF HUMAN HEALTH - CARCINOGENS</b>					
Acrylonitrile	µg/L	--	--	--	8.80E+00
	lb/day	--	--	--	2.64E-01
Aldrin	µg/L	--	--	--	1.94E-03
	lb/day	--	--	--	5.81E-05
Benzene	µg/L	--	--	--	5.19E+02
	lb/day	--	--	--	1.56E+01
Benzidine	µg/L	--	--	--	6.07E-03
	lb/day	--	--	--	1.82E-04
Beryllium	µg/L	--	--	--	2.90E+00
	lb/day	--	--	--	8.72E-02
Bis(2-chloroethyl) Ether	µg/L	--	--	--	3.96E+00
	lb/day	--	--	--	1.19E-01
Bis(2-ethylhexyl) Phthalate	µg/L	--	--	--	3.08E+02
	lb/day	--	--	--	9.25E+00
Carbon Tetrachloride	µg/L	--	--	--	7.92E+01
	lb/day	--	--	--	2.38E+00
Chlorodane	µg/L	--	--	--	2.02E-03
	lb/day	--	--	--	6.08E-05
Chlorodibromomethane	µg/L	--	--	--	7.57E+02
	lb/day	--	--	--	2.27E+01
Chloroform	µg/L	--	--	--	1.14E+04
	lb/day	--	--	--	3.43E+02
DDT <sup>6</sup>	µg/L	--	--	--	1.50E-02
	lb/day	--	--	--	4.49E-04
1,4-dichlorobenzene	µg/L	--	--	--	1.58E+03
	lb/day	--	--	--	4.76E+01
3,3'-dichlorobenzidine	µg/L	--	--	--	7.13E-01
	lb/day	--	--	--	2.14E-02
1,2-dichloroethane	µg/L	--	--	--	2.46E+03
	lb/day	--	--	--	7.40E+01

Parameter	Unit	Performance Goals <sup>1</sup>			
		6-Month Median	Maximum Daily	Instantaneous Maximum	30-Day Average
1,1-dichloroethylene	µg/L	--	--	--	7.92E+01
	lb/day	--	--	--	2.38E+00
Dichlorobromomethane	µg/L	--	--	--	5.46E+02
	lb/day	--	--	--	1.64E+01
Dichloromethane	µg/L	--	--	--	3.96E+04
	lb/day	--	--	--	1.19E+03
1,3-dichloropropene	µg/L	--	--	--	7.83E+02
	lb/day	--	--	--	2.35E+01
Dieldrin	µg/L	--	--	--	3.52E-03
	lb/day	--	--	--	1.06E-04
2,4-dinitrotoluene	µg/L	--	--	--	2.29E+02
	lb/day	--	--	--	6.87E+00
1,2-diphenylhydrazine	µg/L	--	--	--	1.41E+01
	lb/day	--	--	--	4.23E-01
Halomethanes <sup>7</sup>	µg/L	--	--	--	1.14E+04
	lb/day	--	--	--	3.43E+02
Heptachlor	µg/L	--	--	--	4.40E-03
	lb/day	--	--	--	1.32E-04
Heptachlor Epoxide	µg/L	--	--	--	1.76E-03
	lb/day	--	--	--	5.28E-05
Hexachlorobenzene	µg/L	--	--	--	1.85E-02
	lb/day	--	--	--	5.55E-04
Hexachlorobutadiene	µg/L	--	--	--	1.23E+03
	lb/day	--	--	--	3.70E+01
Hexachloroethane	µg/L	--	--	--	2.20E+02
	lb/day	--	--	--	6.61E+00
Isophorone	µg/L	--	--	--	6.42E+04
	lb/day	--	--	--	1.93E+03
N-nitrosodimethylamine	µg/L	--	--	--	6.42E+02
	lb/day	--	--	--	1.93E+01
N-nitrosodi-N-propylamine	µg/L	--	--	--	3.34E+01
	lb/day	--	--	--	1.00E+00
N-nitrosodiphenylamine	µg/L	--	--	--	2.20E+02
	lb/day	--	--	--	6.61E+00
PAHs <sup>8</sup>	µg/L	--	--	--	7.74E-01
	lb/day	--	--	--	2.33E-02
PCBs <sup>9</sup>	µg/L	--	--	--	1.67E-03
	lb/day	--	--	--	5.02E-05

Parameter	Unit	Performance Goals <sup>1</sup>			
		6-Month Median	Maximum Daily	Instantaneous Maximum	30-Day Average
TCDD equivalents <sup>10</sup>	µg/L	--	--	--	3.43E-07
	lb/day	--	--	--	1.03E-08
1,1,2,2-tetrachloroethane	µg/L	--	--	--	2.02E+02
	lb/day	--	--	--	6.08E+00
Tetrachloroethylene	µg/L	--	--	--	1.76E+02
	lb/day	--	--	--	5.28E+00
Toxaphene	µg/L	--	--	--	1.85E-02
	lb/day	--	--	--	5.55E-04
Trichloroethylene	µg/L	--	--	--	2.38E+03
	lb/day	--	--	--	7.13E+01
1,1,2-trichloroethane	µg/L	--	--	--	8.27E+02
	lb/day	--	--	--	2.48E+01
2,4,6-trichlorophenol	µg/L	--	--	--	2.55E+01
	lb/day	--	--	--	7.66E-01
Vinyl Chloride	µg/L	--	--	--	3.17E+03
	lb/day	--	--	--	9.51E+01

<sup>1</sup> Scientific "E" notation is used to express certain values. In scientific "E" notation, the number following the "E" indicates that position of the decimal point in the value. Negative numbers after the "E" indicate that the value is less than 1, and positive numbers after the "E" indicate that the value is greater than 1. In this notation a value of 6.1E-02 represents  $6.1 \times 10^{-2}$  or 0.061, 6.1E+02 represents  $6.1 \times 10^2$  or 610, and 6.1E+00 represents  $6.1 \times 10^0$  or 6.1.

<sup>2</sup> Dischargers may, at their option, meet this limitation (or apply this performance goal) as a total chromium limitation (or performance goal).

<sup>3</sup> If a Discharger can demonstrate to the satisfaction of the Regional Water Board (subject to USEPA approval) that an analytical method is available to reliably distinguish between strongly and weakly complexed cyanide, effluent limitations for cyanide may be met by (or performance goals may be evaluated with) the combined measurement of free cyanide, simple alkali metals cyanides, and weakly complexed organometallic cyanide complexes. In order for the analytical method to be acceptable, the recovery of free cyanide from metal complexes must be comparable to that achieved by the approved method in 40 CFR 136, as revised May 14, 1999.

<sup>4</sup> HCH (hexachlorocyclohexane) represents the sum of the alpha, beta, gamma (Lindane), and delta isomers of hexachlorocyclohexane.

<sup>5</sup> Dichlorobenzenes represent the sum of 1,2- and 1,3-dichlorobenzene.

<sup>6</sup> DDD (dichlorodiphenyldichloroethane), DDE (dichlorodiphenyldichloroethylene), and DDT (dichlorodiphenyltrichloroethane) represent the sum of 4,4' DDT; 2,4' DDT; 4,4' DDE; 2,4' DDE; 4,4' DDD; and 2,4' DDD.

<sup>7</sup> Halomethanes represent the sum of bromoform, bromomethane (methyl bromide), and chloromethane (methyl chloride).

<sup>8</sup> PAHs (polynuclear aromatic hydrocarbons) represent the sum of acenaphthalene; anthracene; 1,2-benzanthracene; 3,4-benzofluoranthene; benzo[k]fluoranthene; 1,1,2-benzoperylene; benzo[a]pyrene; chrysene; dibenzo[a,h]anthracene; fluorine; indeno[1,2,3-cd]pyrene; phenanthrene; and pyrene.

<sup>9</sup> PCBs (polychlorinated biphenyls) represent the sum of chlorinated biphenyls whose analytical characteristics resemble those of Aroclor-1016, Aroclor-1221, Aroclor-1232, Aroclor-1242, Aroclor-1248, Aroclor-1254, and Aroclor-1260.

<sup>10</sup> TCDD equivalents represent the sum of concentrations of chlorinated dibenzodioxins (2,3,7,8-CDDs) and chlorinated dibenzofurans (2,3,7,8-CDFs) multiplied by their respective toxicity factors, as shown by the table below. USEPA Method 8280 may be used to analyze TCDD equivalents.

Isomer Group	Toxicity Equivalence Factor
2,3,7,8 – tetra CDD	1.0
2,3,7,8 – penta CDD	0.5
2,3,7,8 – hexa CDD	0.1
2,3,7,8 – hepta CDD	0.01
octa CDD	0.001
2,3,7,8 – tetra CDF	0.1
1,2,3,7,8 – penta CDF	0.05
2,3,4,7,8 – penta CDF	0.5
2,3,7,8 – hexa CDFs	0.1
2,3,7,8 – hepta CDFs	0.01
Octa CDF	0.001

<sup>11</sup> Endosulfan shall mean the sum of alpha-endosulfan, beta-endosulfan, and endosulfan sulfate.

### 1. Satisfaction of Anti-Backsliding Requirements

The technology based-effluent limitations in this Order are at least as stringent as the effluent limitations in the previous Order. WQBELs for copper and total residual chlorine have been revised to be consistent with the revised outfall dilution of 87:1 and the implementation procedures of the Ocean Plan.

Effluent limitations from Order No. R9-2003-0155 are not retained for constituents for which RPA results indicated Endpoint 2 and Endpoint 3: instead performance goals have been assigned for these constituents. Parameters for which Endpoint 2 was concluded are determined not to have reasonable potential, thus it is inappropriate to establish effluent limitations for these parameters. For parameters for which Endpoint 3 was concluded, reasonable potential was not determined. However, the RPA results are inconclusive. Because all Table B parameters were established as effluent limitations in the previous Order, without the use of a RPA during the previous permit renewal, these effluent limitations appear to be based on the blanket assignment of water quality objectives as effluent limitations. The practice of assigning all water quality objectives as effluent limitations was a main factor for the 2005 Ocean Plan revision to include procedures for an RPA, to eliminate unnecessary burden on the Dischargers and to establish a more equitable procedure that would be protective of water quality objectives. Thus, parameters for which new data is available, and reasonable potential can not be determined, effluent limitations have been removed as allowed under 40 CFR 122(l)(2)(i)(B), and performance goals have been established in their place.

The MRP for this Order is designed to obtain additional information for these constituents to determine if reasonable potential exists for these constituents in future permit renewals and/or updates.

This permit complies with all applicable federal and State anti-backsliding regulations.

## 2. Satisfaction of Antidegradation Policy

Waste Discharge Requirements for the Discharger must conform with federal and State antidegradation policies provided at 40 CFR 131.12 and in State Water Board Resolution No. 68-16, *Statement of Policy with Respect to Maintaining High Quality of Waters in California*. The antidegradation policies require that beneficial uses and the water quality necessary to maintain those beneficial uses in the receiving waters of the discharge shall be maintained and protected, and, if existing water quality is better than the quality required to maintain beneficial uses, the existing water quality shall be maintained and protected unless allowing a lowering of water quality is necessary to accommodate important economic and social development or consistent with maximum benefit to the people of California. When a significant lowering of water quality is allowed by the Regional Water Board, an antidegradation analysis is required in accordance with the *State Water Board's Administrative Procedures Update (July 2, 1990), Antidegradation Policy Implementation for NPDES Permitting*.

### a. The Technology-based Effluent Limitations

The technology-based effluent limitations are at least as stringent as the previous effluent limitations, and no degradation of the receiving water is expected.

### b. Water Quality-based Effluent Limitations

The water quality-based effluent limitations contained in this Order have been modified from previous NPDES permits for the Discharger, including Order No. R9-2003-0155, due to a recalculation of the ocean outfall initial dilution factor and removal of effluent limitations after a RPA. In accordance with the State Water Board's Administrative Procedures Update, the Regional Water Board assessed the potential impact of the modified effluent limitations on existing water quality and the need for an antidegradation analysis as follows:

#### i. Recalculation of OOO Initial Dilution Factor

The new recalculated Dm of 87:1, which is based on an OOO total permitted flow rate of 29.055 MGD, is an increase over the previous permit's Dm of 82:1 which was based on the permitted total flow rate in 2000 through the OOO of 21.3 MGD. The new Dm of 87:1 used in the calculation of water quality-based effluent limitations and performance goals in this Order result in a relaxation of water quality-based effluent limitations and performance goals in this Order compared to the those in Order No. R9-2003-0155 and also reflects an expansion of the zone of initial dilution (ZID), both of which may indicate a lowering of water quality.

Based on the revised initial dilution, an approximate increase of 6 percent has been granted in effluent limitations and performance goals. Based on this small percentage, this lowering of water quality is not expected to be

significant and is not expected to cause adverse effects to the overall receiving water. Furthermore, the calculation of 6 percent assumes that the effluent will contain pollutants at the concentration of the effluent limitations or performance goals, whereas historical effluent data for the discharge through the OOO indicates that the concentration of constituents listed under Table B of the Ocean Plan in the effluent discharged are considerably lower. For these reasons, the Regional Water Board has determined that an antidegradation analysis is not required to consider the possible impacts resulting from the recalculation of the initial dilution factor and subsequent relaxation of effluent limitations and performance goals.

The recalculation of Dm at the current permitted total flow rate of 29.055 MGD also indicated that the zone of initial dilution (ZID) expands to 78.5 feet from the outfall diffuser which is approximately 20 feet greater to compared to the ZID if the total flow rate was the previous total permitted flow rate of 20.9 MGD. The ZID is recognized as the mixing zone in the receiving water where water quality objectives may be exceeded however adverse effects to the overall receiving water body must be prevented. The computer model results indicate that lowering of water quality may occur in the area up to five feet from the outfall diffuser by an increment not greater than 200% of the WQO for a given constituent and by an increment not greater than 50 % of the WQO in the area five feet to 78.5 feet from the outfall diffuser. In addition to being spatially limited, the incremental lowering of water quality in the ZID is expected to be temporally limited because, as explained previously, the concentrations of a given constituent in the effluent discharged through the OOO have historically been considerably lower than the effluent limitations except for exceptional circumstances of short-term duration. For these reasons, the lowering of water quality within the ZID is not expected to be significant and is not expected to cause adverse effects to the overall receiving water. Therefore, the Regional Water Board has determined that an antidegradation analysis is not required to consider the possible impacts resulting from the recalculation of the initial dilution factor, and the expansion of the ZID.

ii. **Removal of Effluent Limitations after a RPA**

Effluent limitations were not included in this Order for constituents which reasonable potential to exceed the water quality objectives was not indicated following a reasonable potential analysis although the previous permit included effluent limitations for those constituents. The procedures for conducting the reasonable potential analysis are explained elsewhere in this Fact Sheet. For constituents for which effluent limitations were not included, performance goals were included which will indicate the level of discharge at which possible water quality impacts may be significant. The removal of effluent limitations by itself is not expected to cause a change

in the physical nature of the effluent discharged and is not expected to impact beneficial uses nor cause a reduction of the water quality of the receiving water. Coupled with the inclusion of performance goals and retention of the monitoring program for constituents without effluent limitations, the existing water quality is expected to be maintained. For these reasons, the Regional Water Board has determined that an antidegradation analysis is not required to consider the possible impacts resulting from the removal of effluent limitations following a RPA.

### **3. Stringency of Requirements for Individual Pollutants**

This Order contains both technology-based and water quality-based effluent limitations for individual pollutants. The technology-based effluent limitations consist of restrictions on BOD<sub>5</sub>, TSS, oil and grease, settleable solids, turbidity, and pH. Restrictions on BOD<sub>5</sub>, TSS, oil and grease, settleable solids, turbidity, and pH are discussed in section IV.B of this Fact Sheet. This Order's technology-based pollutant restrictions implement the minimum, applicable federal technology-based requirements. These limitations are not more stringent than required by the CWA.

Water quality-based effluent limitations have been scientifically derived to implement water quality objectives that protect beneficial uses. Both the beneficial uses and the water quality objectives have been approved pursuant to federal law and are the applicable federal water quality standards. The scientific procedures for calculating the individual water quality-based effluent limitations are based on the Ocean Plan, which was approved by USEPA on February 14, 2006. All beneficial uses and water quality objectives contained in the Basin Plan were approved under State law and submitted to and approved by USEPA prior to May 30, 2000. Any water quality objectives and beneficial uses submitted to USEPA prior to May 30, 2000, but not approved by USEPA before that date, are nonetheless "applicable water quality standards for purposes of the CWA" pursuant to section 131.21(c)(1). Collectively, this Order's restrictions on individual pollutants are no more stringent than required to implement the requirements of the CWA.

#### **F. Interim Effluent Limitations – Not Applicable**

#### **G. Land Discharge Specifications – Not Applicable**

#### **H. Reclamation Specifications – Not Applicable**

### **V. RATIONALE FOR RECEIVING WATER LIMITATIONS**

Receiving water limitations of this Order are derived from the water quality objectives for ocean waters established by the Basin Plan and the Ocean Plan.

### **VI. RATIONALE FOR MONITORING AND REPORTING REQUIREMENTS**

Section 122.48 requires that all NPDES permits specify requirements for recording and reporting monitoring results. Water Code sections 13267 and 13383 authorizes the



Regional Water Board to require technical and monitoring reports. The Monitoring and Reporting Program (MRP), Attachment E of this Order, establishes monitoring and reporting requirements to implement federal and State requirements. The following provides the rationale for the monitoring and reporting requirements contained in the MRP for this facility.

### **A. Influent Monitoring**

Influent monitoring is required to determine the effectiveness of the source control program, to assess the performance of treatment facilities, and to evaluate compliance with effluent limitations.

Influent monitoring requirements have been carried over from the previous Order.

### **B. Effluent Monitoring**

Effluent monitoring is required to determine compliance with the permit conditions and to identify operational problems and improve plant performance. Effluent monitoring also provides information on wastewater characteristics and flows for use in interpreting water quality and biological data.

Effluent monitoring requirements have been carried over from the previous Order. Effluent monitoring for oil and grease has been increased from once a month, to once a week to ensure the removal of the 25 mg/L influent requirement does not result in effluent exceedances. Effluent monitoring for copper has been increased from once a quarter, to once a month, to assess compliance with the newly established effluent limitation contained in section IV.A of Order No. R9-2008-0096.

### **C. Whole Effluent Toxicity Testing Requirements**

Whole effluent toxicity testing (acute and chronic) have been established to determine compliance with the effluent limitation for chronic toxicity, and the performance goal for acute toxicity.

### **D. Receiving Water Monitoring**

#### **1. Surface Water**

##### **a. Microbiological (Near Shore and Off Shore)**

The near shore and off shore water quality sampling program is designed to help evaluate the fate of the wastewater plume under various conditions and to determine if the California Ocean Plan standards are being negatively impacted by the discharge. Further, bacterial sampling is required to provide data to help track the wastewater plume in the offshore waters, to evaluate compliance with recreational water standards in the kelp beds, and to address issues of beach water quality at the shoreline stations.

Monitoring requirements, consistent with other major OOO dischargers, have been established.

**b. Benthic Monitoring**

Sediment and infauna monitoring is required to help evaluate the potential effects of the discharge on the physical and chemical properties of the sediment and biological communities in the vicinity of the discharge.

Monitoring requirements, consistent with other major OOO dischargers, have been established.

**c. Fish and Invertebrate**

Fish and invertebrate monitoring is required to assess the effects of the discharge on local fish and megabenthic invertebrate communities in the surrounding area of the discharge location.

Monitoring requirements, consistent with other major OOO dischargers, have been established.

**E. Other Monitoring Requirements**

- 1. Kelp Bed Monitoring.** Kelp bed monitoring is intended to assess the extent to which the discharge of wastes may affect the aerial extent and health of coastal kelp beds. The aerial extent of the various kelp beds photographed in each survey will provide a baseline for future monitoring to help evaluate any significant and persistent losses to the kelp beds.
- 2. Regional Monitoring.** The Discharger is required to participate in regional monitoring activities coordinated by the Southern California Coastal Water Project (SCCWRP). The procedures for Executive Officer and USEPA approval shall be the same as detailed above for the strategic process studies. The intent of regional monitoring activities is to maximize the efforts of all monitoring partners using a more cost-effective monitoring design and to best utilize the pooled scientific resources of the region. During these coordinated sampling efforts, the Discharger's sampling and analytical effort may be reallocated to provide a regional assessment of the impact of the discharge of municipal wastewater to the Southern California Bight. Anticipated modifications to the monitoring program will be coordinated so as to provide a more comprehensive picture of the ecological and statistical significance of monitoring results and to determine cumulative impacts of various pollution sources. The Discharger has participated in regional monitoring efforts in 1994, 1998, and 2003, and is participating in the regional monitoring effort for 2008.
- 3. Solids Monitoring.** The Discharger is required to monitoring solids generated at the Facility pursuant to 40 CFR 503.

- 4. Sanitary Sewer Overflow.** The Discharger is required to report sanitary sewer overflows to meet the minimum reporting requirements established by the State Water Board in Order No. 2006-0003-DWQ.

## **VII. RATIONALE FOR PROVISIONS**

### **A. Standard Provisions**

Standard Provisions, which apply to all NPDES permits in accordance with section 122.41, and additional conditions applicable to specified categories of permits in accordance with section 122.42, are provided in Attachment D to the Order.

Section 122.41(a)(1) and (b) through (n) establish conditions that apply to all State-issued NPDES permits. These conditions must be incorporated into the permits either expressly or by reference. If incorporated by reference, a specific citation to the regulations must be included in the Order. Section 123.25(a)(12) allows the State to omit or modify conditions to impose more stringent requirements. In accordance with section 123.25, this Order omits federal conditions that address enforcement authority specified in sections 122.41(j)(5) and (k)(2) because the enforcement authority under the Water Code is more stringent. In lieu of these conditions, this Order incorporates by reference Water Code section 13387(e).

### **B. Special Provisions**

#### **1. Reopener Provisions**

Order No. R9-2008-0096 may be re-opened and modified, revoked, and reissued or terminated in accordance with the provisions of 40 CFR Parts 122, 123, 124, and 125. The Regional Water Board may reopen the permit to modify permit conditions and requirements. Causes for modifications include the promulgation of new regulations, modification in sludge use or disposal practices, or adoption of new regulations by the State Water Board or Regional Water Board, including revisions to the Basin Plan.

#### **2. Special Studies and Additional Monitoring Requirements**

##### **a. Whole Effluent Toxicity (WET)**

- i. Implementing provisions at Section III.C of the Ocean Plan require chronic toxicity monitoring for ocean waste discharges with a minimum initial dilution factor below 100:1. In addition, reasonable potential has been carried over from the previous Order for chronic toxicity, thus monitoring is required. Based on methods of the California Ocean Plan, a maximum daily effluent limitation of 88 TU<sub>c</sub> is established in the Order and monthly monitoring is carried over from Order No. R9-2003-0155.
- ii. Monitoring and Reporting Program No. R9-2003-0155 (MRP) established monthly monitoring requirements for acute toxicity. This requirement is

carried over from the previous Order. A performance goal for acute toxicity of 26.4 TUa is established based on “Equation 2” provided in Section III.C.3.b in the Ocean Plan.

- iii. Provision F.23 of Order No. R9-2003-0155 required the Discharger to submit to the Regional Water Board a Toxicity Reduction Evaluation (TRE) workplan if toxicity testing demonstrated consistent violations of the chronic toxicity limitation. This Order requires the Discharger to maintain an up-to-date TRE workplan, and submit the TRE workplan within 180 days of the effective date of this Order. The workplan shall describe steps the Discharger intends to follow if the effluent limitation for chronic toxicity (88 TUc) or the performance goal for acute toxicity (26.4 TUa) is exceeded.
- iv. The Toxicity Reduction Evaluation and Toxicity Identification Evaluation (TIE) requirements established in Order No. R9-2003-0155 are carried over. If the toxicity effluent limitation is exceeded, then within 15 days of the exceedance, the Discharger shall begin conducting six additional tests, bi-weekly, over a 12 week period. If the toxicity effluent limitation is exceeded in any of these six additional tests, then the Discharger shall notify the Executive Officer and Director. If the Executive Officer and Director determine that the discharge consistently exceeds a toxicity effluent limitation, then the Discharger shall initiate a TRE/TIE in accordance with the TRE workplan, *Toxicity Reduction Evaluation Guidance for Municipal Wastewater Treatment Plants* (USEPA 833-B-99-002, 1999), and USEPA TIE guidance documents (Phase I, EPA/600/6-91/005F, 1992; Phase II, EPA/600/R-92/080, 1993; and Phase III, EPA/600/R-92/081, 1993). If no toxicity is detected in any of these additional six tests, then the Discharger may return to the testing frequency specified in the MRP.

**3. Best Management Practices and Pollution Prevention – Not Applicable**

**4. Construction, Operation, and Maintenance Specifications – Not Applicable**

**5. Special Provisions for Municipal Facilities (POTWs Only)**

**a. Treatment Plant Capacity**

Order No. R9-2008-0096 establishes a requirement for a treatment plant capacity study to serve as an indicator for the Regional Water Board of the Facility’s increasing hydraulic capacity and growth in the service area.

**b. Source Control Program**

A source control program is required to prevent the introduction of pollutants, which will interfere with treatment plant operations or sludge disposal, and prevent pass through of pollutants that exceed water quality objectives, standards or permit limitations. The Source Control Program requirements are based on the requirements from Order No. R9-2003-0155.

- c. Biosolids.** The use and disposal of biosolids is regulated under federal and State laws and regulations, including permitting requirements and technical standards included in 40 CFR Part 503. The Discharger is required to comply with the standards and time schedules contained in 40 CFR Part 503.

Title 27, CCR, Division 2, Subdivision 1, section 20005 establishes approved methods for the disposal of collected screenings, residual sludge, biosolids, and other solids removed from liquid wastes. Requirements to ensure the Discharger disposes of solids in compliance with State and federal regulations has been included in this Order.

- d. Sanitary Sewer System Requirements.** Sanitary sewer overflows (SSOs) often contain high levels of suspended solids, pathogenic organisms, toxic pollutants, nutrients, oxygen-demanding organic compounds, oil and grease and other pollutants. SSOs may cause a public nuisance, particularly when raw untreated wastewater is discharged to areas with high public exposure, such as streets or surface waters used for drinking, fishing, or body contact recreation. SSOs may pollute surface or ground waters, threaten public health, adversely affect aquatic life, and impair the recreational use and aesthetic enjoyment of surface waters.

The State Water Board establishes minimum requirements to prevent SSOs in Order No. 2006-0003-DWQ. These requirements are established as a condition of this Order and are contained in Attachment H to this Order. Minimum monitoring and reporting requirements specified in Monitoring and Reporting Program No. 2006-0003-DWQ have been established in Attachment E to this Order.

## **6. Other Special Provisions – Not Applicable**

## **7. Compliance Schedules - Not Applicable**

# **VIII. PUBLIC PARTICIPATION**

The Regional Water Board is considering the issuance of WDRs that will serve as a NPDES permit for the US Marine Corps Base, Camp Pendleton, Southern Region Tertiary Treatment Plant. As a step in the WDR adoption process, the Regional Water Board staff has developed tentative WDRs. The Regional Water Board encourages public participation in the WDR adoption process.

## **A. Notification of Interested Parties**

The Regional Water Board has notified the Discharger and interested agencies and persons of its intent to prescribe waste discharge requirements for the discharge and has provided them with an opportunity to submit their written comments and recommendations. Notification was published in the San Diego Union Tribune on August 4, 2008 and posted on the Regional Water Board web site on August 7, 2008.

## **B. Written Comments**

The staff determinations are tentative. Interested persons are invited to submit written comments concerning these tentative WDRs. Comments must be submitted either in person or by mail to the Executive Office at the Regional Water Board at the address above on the cover page of this Order.

To be fully responded to by staff and considered by the Regional Water Board, written comments must be received at the Regional Water Board offices by 5:00 p.m. on September 3, 2008.

## **C. Public Hearing**

The Regional Water Board will hold a public hearing on the tentative WDRs during its regular Board meeting on the following date and time and at the following location:

Date: September 10, 2008  
Time: 9:00 AM  
Location: Rancho California Water District  
District Board Room  
42135 Winchester Road  
Temecula, CA 92590

Interested persons are invited to attend. At the public hearing, the Regional Water Board will hear testimony, if any, pertinent to the discharge, WDRs, and permit. Oral testimony will be heard; however, for accuracy of the record, important testimony should be in writing.

Please be aware that dates and venues may change. Our Web address is <http://www.swrcb.ca.gov/rwqcb9> where you can access the current agenda for changes in dates and locations.

## **D. Waste Discharge Requirements Petitions**

Any aggrieved person may petition the State Water Resources Control Board to review the decision of the Regional Water Board regarding the final WDRs. The petition must be submitted within 30 days of the Regional Water Board's action to the following address:

State Water Resources Control Board  
Office of Chief Counsel  
P.O. Box 100, 1001 I Street  
Sacramento, CA 95812-0100

## **E. Information and Copying**

The Report of Waste Discharge (RWD), related documents, tentative effluent limitations and special provisions, comments received, and other information are on file and may

be inspected at the address above at any time between 8:30 a.m. and 4:45 p.m., Monday through Friday. Copying of documents may be arranged through the Regional Water Board by calling (858) 467-2952.

**F. Register of Interested Persons**

Any person interested in being placed on the mailing list for information regarding the WDRs and NPDES permit should contact the Regional Water Board, reference this facility, and provide a name, address, and phone number.

**G. Additional Information**

Requests for additional information or questions regarding this Order should be directed to Melissa Valdovinos at (858) 467-2724.

## **Attachment G - Summary of Discharge Prohibitions contained in the Ocean Plan and Basin Plan**

### **I. Ocean Plan Discharge Prohibitions**

- A. The Discharge of any radiological chemical, or biological warfare agent or high-level radioactive waste into the ocean is prohibited.
- B. Waste shall not be discharged to designated Areas of Special Biological Significance except as provided in Chapter III.E. of the Ocean Plan.
- C. Pipeline discharge of sludge to the ocean is prohibited by federal law; the discharge of municipal and industrial waste sludge directly to the ocean, or into a waste stream that discharges to the ocean, is prohibited. The discharge of sludge digester supernatant directly to the ocean, or to a waste stream that discharges to the ocean without further treatment, is prohibited.
- D. The by-passing of untreated wastes containing concentrations of pollutants in excess of those of Table A or Table B [of the Ocean Plan] is prohibited.

### **II. Basin Plan Discharge Prohibitions**

- A. The discharge of waste to waters of the State in a manner causing, or threatening to cause a condition of pollution, contamination or nuisance as defined in Water Code section 13050, is prohibited.
- B. The discharge of waste to land, except as authorized by WDRs of the terms described in Water Code section 13264 is prohibited.
- C. The discharge of pollutants or dredged or fill material to waters of the United States except as authorized by an NPDES permit or a dredged or fill material permit (subject to the exemption described in Water Code section 13376) is prohibited.
- D. Discharges of recycled water to lakes or reservoirs used for municipal water supply or to inland surface water tributaries thereto are prohibited, unless this Regional Water Board issues a NPDES permit authorizing such a discharge; the proposed discharge has been approved by the State DHS and the operating agency of the impacted reservoir; and the discharger has an approved fail-safe long-term disposal alternative.
- E. The discharge of waste to inland surface waters, except in cases where the quality of the discharge complies with applicable receiving water quality objectives, is prohibited. Allowances for dilution may be made at the discretion of the Regional Water Board. Consideration would include streamflow data, the degree of treatment provided and safety measures to ensure reliability of facility performance. As an example, discharge of secondary effluent would probably be permitted if streamflow provided 100:1 dilution capability.



- F. The discharge of waste in a manner causing flow, ponding, or surfacing on lands not owned or under the control of the discharger is prohibited, unless the discharge is authorized by the Regional Water Board.
- G. The dumping, deposition, or discharge of waste directly into waters of the State, or adjacent to such waters in any manner which may permit its being transported into the waters, is prohibited unless authorized by the Regional Water Board.
- H. Any discharge to a storm water conveyance system that is not composed entirely of storm water is prohibited unless authorized by the Regional Water Board. [The federal regulations, 40 CFR 122.26(b)(13), define storm water as storm water runoff, snow melt runoff, and surface runoff and drainage. 40 CFR 122.26(b)(2) defines an illicit discharge as any discharge to a storm water conveyance system that is not composed entirely of storm water except discharges pursuant to a NPDES permit and discharges resulting from fire fighting activities.] [Section 122.26 amended at 56 FR 56553, November 5, 1991; 57 FR 11412, April 2, 1992].
- I. The unauthorized discharge of treated or untreated sewage to waters of the State or to a storm water conveyance system is prohibited.
- J. The discharge of industrial wastes to conventional septic tank/ subsurface disposal systems, except as authorized by the terms described in Water Code section 13264, is prohibited.
- K. The discharge of radioactive wastes amenable to alternative methods of disposal into the waters of the State is prohibited.
- L. The discharge of any radiological, chemical, or biological warfare agent into waters of the State is prohibited.
- M. The discharge of waste into a natural or excavated site below historic water levels is prohibited unless the discharge is authorized by the Regional Water Board.
- N. The discharge of sand, silt, clay, or other earthen materials from any activity, including land grading and construction, in quantities which cause deleterious bottom deposits, turbidity or discoloration in waters of the State or which unreasonably affect, or threaten to affect, beneficial uses of such waters is prohibited.
- O. The discharge of treated or untreated sewage from vessels to Mission Bay, Oceanside Harbor, Dana Point Harbor, or other small boat harbors is prohibited.
- P. The discharge of untreated sewage from vessels to San Diego Bay is prohibited.
- Q. The discharge of treated sewage from vessels to portions of San Diego Bay that are less than 30 feet deep at MLLW is prohibited.

- R. The discharge of treated sewage from vessels, which do not have a properly functioning USCG certified Type 1 or Type II marine sanitation device, to portions of San Diego Bay that are greater than 30 feet deep at MLLW is prohibited.

## **ATTACHMENT H**

### **SANITARY SEWER SYSTEMS REQUIREMENTS**

#### **A. PROHIBITIONS**

1. Any SSO that results in a discharge of untreated or partially treated wastewater to waters of the United States is prohibited.
2. Any SSO that results in a discharge of untreated or partially treated wastewater that creates a nuisance as defined in California Water Code Section 13050(m) is prohibited.

#### **B. PROVISIONS**

1. The Discharger shall take all feasible steps to eliminate SSOs. In the event that an SSO does occur, the Discharger shall take all feasible steps to contain and mitigate the impacts of an SSO.
2. In the event of an SSO, the Discharger shall take all feasible steps to prevent untreated or partially treated wastewater from discharging from storm drains into flood control channels or waters of the United States by blocking the storm drainage system and by removing the wastewater from the storm drains.
3. All SSOs must be reported in accordance with section C of this attachment.
4. In any enforcement action, the State and/or Regional Water Boards will consider the appropriate factors under the duly adopted State Water Board Enforcement Policy. And, consistent with the Enforcement Policy, the State and/or Regional Water Boards must consider the Discharger's efforts to contain, control, and mitigate SSOs when considering the California Water Code Section 13327 factors. In assessing these factors, the State and/or Regional Water Boards will also consider whether:
  - (i) The Discharger has complied with the requirements of this Order, including requirements for reporting and developing and implementing a SSMP;
  - (ii) The Discharger can identify the cause or likely cause of the discharge event;
  - (iii) There were no feasible alternatives to the discharge, such as temporary storage or retention of untreated wastewater, reduction of inflow and infiltration, use of adequate backup equipment, collecting and hauling of untreated wastewater to a treatment facility, or an increase in the capacity of the system as necessary to contain the design storm event identified in the SSMP. It is inappropriate to consider the lack of feasible alternatives, if the Discharger does not implement a periodic or continuing process to identify and correct problems.

- (iv) The discharge was exceptional, unintentional, temporary, and caused by factors beyond the reasonable control of the Discharger;
  - (v) The discharge could have been prevented by the exercise of reasonable control described in a certified SSMP for:
    - Proper management, operation and maintenance;
    - Adequate treatment facilities, sanitary sewer system facilities, and/or components with an appropriate design capacity, to reasonably prevent SSOs (e.g., adequately enlarging treatment or collection facilities to accommodate growth, infiltration and inflow (I/I), etc.);
    - Preventive maintenance (including cleaning and fats, oils, and grease (FOG) control);
    - Installation of adequate backup equipment; and
    - Inflow and infiltration prevention and control to the extent practicable.
  - (vi) The sanitary sewer system design capacity is appropriate to reasonably prevent SSOs.
  - (vii) The Discharger took all reasonable steps to stop and mitigate the impact of the discharge as soon as possible.
5. When a sanitary sewer overflow occurs, the Discharger shall take all feasible steps and necessary remedial actions to: 1) control or limit the volume of untreated or partially treated wastewater discharged, 2) terminate the discharge, and 3) recover as much of the wastewater discharged as possible for proper disposal, including any wash down water.

The Discharger shall implement all remedial actions to the extent they may be applicable to the discharge and not inconsistent with an emergency response plan, including the following:

- (i) Interception and rerouting of untreated or partially treated wastewater flows around the wastewater line failure;
  - (ii) Vacuum truck recovery of sanitary sewer overflows and wash down water;
  - (iii) Cleanup of debris at the overflow site;
  - (iv) System modifications to prevent another SSO at the same location;
  - (v) Adequate sampling to determine the nature and impact of the release; and
  - (vi) Adequate public notification to protect the public from exposure to the SSO.
6. The Discharger shall properly, manage, operate, and maintain all parts of the sanitary sewer system owned or operated by the Discharger, and shall ensure that the system

operators (including employees, contractors, or other agents) are adequately trained and possess adequate knowledge, skills, and abilities.

7. The Discharger shall allocate adequate resources for the operation, maintenance, and repair of its sanitary sewer system, by establishing a proper rate structure, accounting mechanisms, and auditing procedures to ensure an adequate measure of revenues and expenditures. These procedures must be in compliance with applicable laws and regulations and comply with generally acceptable accounting practices.
8. The Discharger shall provide adequate capacity to convey base flows and peak flows, including flows related to wet weather events. Capacity shall meet or exceed the design criteria as defined in the Discharger's System Evaluation and Capacity Assurance Plan for all parts of the sanitary sewer system owned or operated by the Discharger.
9. The Discharger shall develop and implement a written Sewer System Management Plan (SSMP) and make it available to the State and/or Regional Water Board upon request. A copy of this document must be publicly available at the Discharger's office and/or available on the Internet. This SSMP must be approved by the Discharger's governing board at a public meeting.
10. In accordance with the California Business and Professions Code sections 6735, 7835, and 7835.1, all engineering and geologic evaluations and judgments shall be performed by or under the direction of registered professionals competent and proficient in the fields pertinent to the required activities. Specific elements of the SSMP that require professional evaluation and judgments shall be prepared by or under the direction of appropriately qualified professionals, and shall bear the professional(s)' signature and stamp.
11. The mandatory elements of the SSMP are specified below. However, if the Discharger believes that any element of this section is not appropriate or applicable to the Discharger's sanitary sewer system, the SSMP program does not need to address that element. The Discharger must justify why that element is not applicable. The SSMP must be approved by the deadlines listed in the SSMP Time Schedule below.

### **Sewer System Management Plan (SSMP)**

- (i) **Goal:** The goal of the SSMP is to provide a plan and schedule to properly manage, operate, and maintain all parts of the sanitary sewer system. This will help reduce and prevent SSOs, as well as mitigate any SSOs that do occur.
- (ii) **Organization:** The SSMP must identify:
  - (a) The name of the responsible or authorized representative as described in section V.B.3 of this Attachment D (Standard Provisions).
  - (b) The names and telephone numbers for management, administrative, and maintenance positions responsible for implementing specific measures in the SSMP

program. The SSMP must identify lines of authority through an organization chart or similar document with a narrative explanation; and

- (c) The chain of communication for reporting SSOs, from receipt of a complaint or other information, including the person responsible for reporting SSOs to the State and Regional Water Board and other agencies if applicable (such as County Health Officer, County Environmental Health Agency, Regional Water Board, and/or State Office of Emergency Services (OES)).
- (iii) **Legal Authority:** The Discharger must demonstrate, through sanitary sewer system use ordinances, service agreements, or other legally binding procedures, that it possesses the necessary legal authority to:
  - (a) Prevent illicit discharges into its sanitary sewer system (examples may include I/I, stormwater, chemical dumping, unauthorized debris and cut roots, etc.);
  - (b) Require that sewers and connections be properly designed and constructed;
  - (c) Ensure access for maintenance, inspection, or repairs for portions of the lateral owned or maintained by the Public Agency;
  - (d) Limit the discharge of fats, oils, and grease and other debris that may cause blockages, and
  - (e) Enforce any violation of its sewer ordinances.
- (iv) **Operation and Maintenance Program.** The SSMP must include those elements listed below that are appropriate and applicable to the Discharger's system:
  - (a) Maintain an up-to-date map of the sanitary sewer system, showing all gravity line segments and manholes, pumping facilities, pressure pipes and valves, and applicable stormwater conveyance facilities;
  - (b) Describe routine preventive operation and maintenance activities by staff and contractors, including a system for scheduling regular maintenance and cleaning of the sanitary sewer system with more frequent cleaning and maintenance targeted at known problem areas. The Preventative Maintenance (PM) program should have a system to document scheduled and conducted activities, such as work orders;
  - (c) Develop a rehabilitation and replacement plan to identify and prioritize system deficiencies and implement short-term and long-term rehabilitation actions to address each deficiency. The program should include regular visual and TV inspections of manholes and sewer pipes, and a system for ranking the condition of sewer pipes and scheduling rehabilitation. Rehabilitation and replacement should focus on sewer pipes that are at risk of collapse or prone to more frequent blockages due to pipe defects. Finally, the rehabilitation and replacement plan should include a

capital improvement plan that addresses proper management and protection of the infrastructure assets. The plan shall include a time schedule for implementing the short- and long-term plans plus a schedule for developing the funds needed for the capital improvement plan;

- (d) Provide training on a regular basis for staff in sanitary sewer system operations and maintenance, and require contractors to be appropriately trained; and
- (e) Provide equipment and replacement part inventories, including identification of critical replacement parts.

(v) **Design and Performance Provisions:**

- (a) Design and construction standards and specifications for the installation of new sanitary sewer systems, pump stations and other appurtenances; and for the rehabilitation and repair of existing sanitary sewer systems; and
- (b) Procedures and standards for inspecting and testing the installation of new sewers, pumps, and other appurtenances and for rehabilitation and repair projects.

(vi) **Overflow Emergency Response Plan:** Each Discharger shall develop and implement an overflow emergency response plan that identifies measures to protect public health and the environment. At a minimum, this plan must include the following:

- (a) Proper notification procedures so that the primary responders and regulatory agencies are informed of all SSOs in a timely manner;
- (b) A program to ensure an appropriate response to all overflows;
- (c) Procedures to ensure prompt notification to appropriate regulatory agencies and other potentially affected entities (e.g. health agencies, Regional Water Boards, water suppliers, etc.) of all SSOs that potentially affect public health or reach the waters of the State in accordance with the MRP. All SSOs shall be reported in accordance with this MRP, the California Water Code, other State Law, and other applicable Regional Water Board WDRs or NPDES permit requirements. The SSMP should identify the officials who will receive immediate notification;
- (d) Procedures to ensure that appropriate staff and contractor personnel are aware of and follow the Emergency Response Plan and are appropriately trained;
- (e) Procedures to address emergency operations, such as traffic and crowd control and other necessary response activities; and
- (f) A program to ensure that all reasonable steps are taken to contain and prevent the discharge of untreated and partially treated wastewater to waters of the United States and to minimize or correct any adverse impact on the environment resulting

from the SSOs, including such accelerated or additional monitoring as may be necessary to determine the nature and impact of the discharge.

(vii) **FOG Control Program:** The Discharger shall evaluate its service area to determine whether a FOG control program is needed. If a Discharger determines that a FOG program is not needed, the Discharger must provide justification for why it is not needed. If FOG is found to be a problem, the Discharger must prepare and implement a FOG source control program to reduce the amount of these substances discharged to the sanitary sewer system. This plan shall include the following as appropriate:

- (a) An implementation plan and schedule for a public education outreach program that promotes proper disposal of FOG;
- (b) A plan and schedule for the disposal of FOG generated within the sanitary sewer system service area. This may include a list of acceptable disposal facilities and/or additional facilities needed to adequately dispose of FOG generated within a sanitary sewer system service area;
- (c) The legal authority to prohibit discharges to the system and identify measures to prevent SSOs and blockages caused by FOG;
- (d) Requirements to install grease removal devices (such as traps or interceptors), design standards for the removal devices, maintenance requirements, BMP requirements, record keeping and reporting requirements;
- (e) Authority to inspect grease producing facilities, enforcement authorities, and whether the Discharger has sufficient staff to inspect and enforce the FOG ordinance;
- (f) An identification of sanitary sewer system sections subject to FOG blockages and establishment of a cleaning maintenance schedule for each section; and
- (g) Development and implementation of source control measures for all sources of FOG discharged to the sanitary sewer system for each section identified in (f) above.

(viii) **System Evaluation and Capacity Assurance Plan:** The Discharger shall prepare and implement a capital improvement plan (CIP) that will provide hydraulic capacity of key sanitary sewer system elements for dry weather peak flow conditions, as well as the appropriate design storm or wet weather event. At a minimum, the plan must include:

- (a) **Evaluation:** Actions needed to evaluate those portions of the sanitary sewer system that are experiencing or contributing to an SSO discharge caused by hydraulic deficiency. The evaluation must provide estimates of peak flows (including flows from SSOs that escape from the system) associated with conditions similar to those causing overflow events, estimates of the capacity of key system components, hydraulic deficiencies (including components of the system with limiting capacity)



and the major sources that contribute to the peak flows associated with overflow events;

- (b) **Design Criteria:** Where design criteria do not exist or are deficient, undertake the evaluation identified in (a) above to establish appropriate design criteria; and
  - (c) **Capacity Enhancement Measures:** The steps needed to establish a short- and long-term CIP to address identified hydraulic deficiencies, including prioritization, alternatives analysis, and schedules. The CIP may include increases in pipe size, I/I reduction programs, increases and redundancy in pumping capacity, and storage facilities. The CIP shall include an implementation schedule and shall identify sources of funding.
  - (d) **Schedule:** The Discharger shall develop a schedule of completion dates for all portions of the capital improvement program developed in (a)-(c) above. This schedule shall be reviewed and updated consistent with the SSMP review and update requirements as described in section B. 12.
- (ix) **Monitoring, Measurement, and Program Modifications:** The Discharger shall:
- (a) Maintain relevant information that can be used to establish and prioritize appropriate SSMP activities;
  - (b) Monitor the implementation and, where appropriate, measure the effectiveness of each element of the SSMP;
  - (c) Assess the success of the preventative maintenance program;
  - (d) Update program elements, as appropriate, based on monitoring or performance evaluations; and
  - (e) Identify and illustrate SSO trends, including: frequency, location, and volume.
- (x) **SSMP Program Audits:** As part of the SSMP, the Discharger shall conduct periodic internal audits, appropriate to the size of the system and the number of SSOs. At a minimum, these audits must occur every two years and a report must be prepared and kept on file. This audit shall focus on evaluating the effectiveness of the SSMP and the Discharger's compliance with the SSMP requirements identified in this subsection (B.11), including identification of any deficiencies in the SSMP and steps to correct them.
- (xi) **Communication Program:** The Discharger shall communicate on a regular basis with the public on the development, implementation, and performance of its SSMP. The communication system shall provide the public the opportunity to provide input to the Discharger as the program is developed and implemented.

The Discharger shall also create a plan of communication with systems that are tributary and/or satellite to the Discharger’s sanitary sewer system.

12. Both the SSMP and the Discharger’s program to implement the SSMP must be certified by the Discharger to be in compliance with the requirements set forth above and must be presented to the Discharger’s governing board for approval. The Discharger shall certify that the SSMP, and subparts thereof, are in compliance with the requirements of this attachment within the time frames identified in the time schedule provided in subsection B.13, below.

In order to complete this certification, the Discharger’s authorized representative must complete the certification portion in the Online SSO Database Questionnaire by checking the appropriate milestone box, printing and signing the automated form, and sending the form to:

State Water Resources Control Board  
 Division of Water Quality  
 Attn: SSO Program Manager  
 P.O. Box 100  
 Sacramento, CA 95812

The SSMP must be updated every five (5) years, and must include any significant program changes. Re-certification by the governing board of the Discharger is required in accordance with B.12 when significant updates to the SSMP are made. To complete the re-certification process, the Discharger shall enter the data in the Online SSO Database and mail the form to the State Water Board, as described above.

13. The Discharger shall comply with these requirements according to the following schedule.

**Sewer System Management Plan Time Schedule**

Task	Completion Date
Reporting Program (section C)	3 months after adoption of this Order
SSMP Development Plan and Schedule (no specific section)	3 months after adoption of this Order
Goals and Organization Structure (section B.11(i)&(II))	12 months after adoption of this Order
Overflow Emergency Response Program (section B.11(vi); Legal Authority (section B.11(iii)); Operation and Maintenance Program (section B.11(iv)); Grease Control Program (section B.11(vii))	18 months after adoption of this Order
Design and Performance (section B.11(v)); System Evaluation and Capacity Assurance Plan (section B.11(viii)); Final SSP, incorporating all of the SSMP requirements (section B.11)	30 months after adoption of this Order

### **C. GENERAL MONITORING AND REPORTING REQUIREMENTS**

1. The Discharger shall comply with the attached Monitoring and Reporting Program No. R9-2008-0096.
2. The Discharger shall comply with all applicable requirements of this Order, including Provision V.E of Attachment D (24-hour reporting requirement).
3. All Dischargers must obtain SSO Database accounts and receive a "Username" and "Password" by registering through the California Integrated Water Quality System (CIWQS). These accounts will allow controlled and secure entry into the SSO Database. Additionally, within 30days of receiving an account and prior to recording spills into the SSO Database, all Dischargers must complete the "Collection System Questionnaire", which collects pertinent information regarding a Discharger's collection system. The "Collection System Questionnaire" must be updated at least every 12 months.
4. Pursuant to Health and Safety Code section 5411.5, any person who, without regard to intent or negligence, causes or permits any untreated wastewater or other waste to be discharged in or on any waters of the State, or discharged in or deposited where it is, or probably will be, discharged in or on any surface waters of the State, as soon as that person has knowledge of the discharge, shall immediately notify the local health officer of the discharge. Discharges of untreated or partially treated wastewater to storm drains and drainage channels, whether man-made or natural or concrete-lined, shall be reported as required above.

Any SSO greater than 1,000 gallons discharged in or on any waters of the State, or discharged in or deposited where it is, or probably will be, discharged in or on any surface waters of the State shall also be reported to the Office of Emergency Services pursuant to California Water Code section 13271.