

CALIFORNIA REGIONAL WATER QUALITY CONTROL BOARD

CENTRAL VALLEY REGION

415 Knollcrest Drive, Suite 100, Redding, California 96002
Phone (530) 224-4845 • FAX (530) 224-4847
<http://www.waterboards.ca.gov/centralvalley>

ORDER NO. R5-2009-0015

NPDES NO. CA0004391

**WASTE DISCHARGE REQUIREMENTS FOR THE
COLLINS PINE COMPANY
CHESTER SAWMILL
PLUMAS COUNTY**

The following Discharger is subject to waste discharge requirements as set forth in this Order:

Table 1. Discharger Information

| | |
|---|---|
| Discharger | Collins Pine Company |
| Name of Facility | Collins Pine Company – Chester Sawmill, Chester |
| Facility Address | 500 Main Street |
| | Chester, CA 96020 |
| | Plumas county |
| The U.S. Environmental Protection Agency (USEPA) and the Regional Water Quality Control Board have classified this discharge as a minor discharge. | |

The discharge by the Collins Pine Company from the discharge points identified below is subject to waste discharge requirements as set forth in this Order:

Table 2. Discharge Location

| Discharge Point | Effluent Description | Discharge Point Latitude | Discharge Point Longitude | Receiving Water |
|------------------------|-----------------------------|---------------------------------|----------------------------------|---|
| 001 | Treated Process Water | 40°, 18', 30" N | 121°, 14', 31" W | Stover Ditch, Tributary to Lake Almanor |

Table 3. Administrative Information

| | |
|---|---|
| This Order was adopted by the Regional Water Quality Control Board on: | 5 February 2009 |
| This Order shall become effective on: | 5 February 2009 |
| This Order shall expire on: | 1 February 2014 |
| The Discharger shall file a Report of Waste Discharge in accordance with title 23, California Code of Regulations, as application for issuance of new waste discharge requirements no later than: | <u>180 days prior to the Order expiration date</u> |

IT IS HEREBY ORDERED, that Order No. R5-2004-0012 is rescinded upon the effective date of this Order except for enforcement purposes, and, in order to meet the provisions contained in division 7 of the Water Code (commencing with section 13000) and regulations adopted thereunder, and the provisions of the federal Clean Water Act (CWA) and regulations and guidelines adopted thereunder, the Discharger shall comply with the requirements in this Order.

I, PAMELA C. CREEDON, Executive Officer, do hereby certify that this Order with all attachments is a full, true, and correct copy of an Order adopted by the California Regional Water Quality Control Board, Central Valley Region, on **5 February 2009**.

PAMELA C. CREEDON, Executive Officer

Table of Contents

| | | |
|------|--|----|
| I. | Facility Information | 2 |
| II. | Findings | 2 |
| III. | Discharge Prohibitions..... | 9 |
| IV. | Effluent Limitations and Discharge Specifications | 10 |
| | A. Effluent Limitations – Discharge Point EFF-001 | 10 |
| | 1. Final Effluent Limitations – Discharge Point EFF-001 | 10 |
| | 2. Interim Effluent Limitations | 11 |
| | B. Land Discharge Specifications – Not Applicable..... | 11 |
| | C. Reclamation Specifications – Not Applicable..... | 11 |
| V. | Receiving Water Limitations | 12 |
| | A. Surface Water Limitations..... | 12 |
| | B. Groundwater Limitations | 14 |
| VI. | Provisions..... | 14 |
| | A. Standard Provisions..... | 14 |
| | B. Monitoring and Reporting Program (MRP) Requirements | 18 |
| | C. Special Provisions..... | 18 |
| | 1. Reopener Provisions | 18 |
| | 2. Special Studies, Technical Reports and Additional Monitoring Requirements | 20 |
| | 3. Best Management Practices and Pollution Prevention | 23 |
| | 4. Construction, Operation and Maintenance Specifications | 25 |
| | 5. Special Provisions for Municipal Facilities (POTWs Only) – Not Applicable | 25 |
| | 6. Other Special Provisions | 25 |
| | 7. Compliance Schedules..... | 27 |
| VII. | Compliance Determination | 28 |

List of Tables

| | | |
|-----------|---|-------|
| Table 1. | Discharger Information | Cover |
| Table 2. | Discharge Location | Cover |
| Table 3. | Administrative Information | Cover |
| Table 4. | Facility Information..... | 2 |
| Table 5. | Basin Plan Beneficial Uses..... | 5 |
| Table 6. | Effluent Limitations | 10 |
| Table 7. | Interim Effluent Limitations | 11 |
| Table 8. | Constituent Study – Copper and Lead..... | 23 |
| Table 9. | Pollution Prevention Plan – Copper and Lead | 24 |
| Table 10. | Salinity Evaluation and Minimization Plan | 28 |

List of Attachments

| | | |
|------------------------------|---|-----|
| Attachment A | – Definitions | A-1 |
| Attachment B-1 | – Map..... | B-1 |
| Attachment B-2 | – Aerial Photograph | B-2 |
| Attachment C | – Flow Schematic..... | C-1 |
| Attachment D | – Standard Provisions..... | D-1 |
| Attachment E | – Monitoring and Reporting Program (MRP)..... | E-1 |
| Attachment F | – Fact Sheet..... | F-1 |

I. FACILITY INFORMATION

The following Discharger is subject to waste discharge requirements as set forth in this Order:

Table 4. Facility Information

| | |
|---|---|
| Discharger | Collins Pine Company |
| Name of Facility | Collins Pine Company – Chester Sawmill |
| Facility Address | 500 Main Street |
| | Chester, CA 96020 |
| | Plumas County |
| Facility Contact, Title, and Phone | Chris Verderber, Manager, 530-258-2111 |
| Mailing Address | SAME |
| Type of Facility | Industrial sawmill and power cogeneration |
| Facility Design Flow | 0.36 mgd |

II. FINDINGS

The California Regional Water Quality Control Board, Central Valley Region (hereinafter Regional Water Board), finds:

A. Background. Collins Pine Company (hereinafter Discharger) is currently discharging pursuant to Order No. R5-2004-0012 and National Pollutant Discharge Elimination System (NPDES) Permit No. CA004391. The Discharger submitted a Report of Waste Discharge, dated June 26, 2008, and applied for a NPDES permit renewal to discharge up to 0.36 mgd of treated process wastewater from the Collins Pine Company – Chester Sawmill, hereinafter Facility. The application was deemed incomplete on July 25, 2008. Additional information was requested, and the application was deemed complete on August 8, 2008.

For the purposes of this Order, references to the “discharger” or “permittee” in applicable federal and state laws, regulations, plans, or policy are held to be equivalent to references to the Discharger herein.

B. Facility Description. The Discharger owns and operates a sawmill and wood-burning cogeneration facility. The treatment system consists of two clarifiers that use polymer to settle solids, before discharging to a series of four holding ponds where solids are settled, and floatables are screened off. Additional pH balance is conducted at the last of the four holding ponds, prior to discharge. Wastewater is discharged from Discharge D-001 (see table on cover page) to Stover Ditch, a water/waters of the United States, [and a tributary to Lake Almanor] within Feather River Hydrologic Unit, Mount Harkness Hydrologic Subarea (No. 518.44), as depicted on interagency hydrologic maps prepared

by the Department of Water Resources (DWR) in August 1986. Attachment B provides a map of the area around the Facility. Attachment C provides a flow schematic of the Facility.

- C. Legal Authorities.** This Order is issued pursuant to section 402 of the federal Clean Water Act (CWA) and implementing regulations adopted by the U.S. Environmental Protection Agency (USEPA) and chapter 5.5, division 7 of the California Water Code (commencing with section 13370). It shall serve as a NPDES permit for point source discharges from this facility to surface waters. This Order also serves as Waste Discharge Requirements (WDRs) pursuant to article 4, chapter 4, division 7 of the Water Code (commencing with section 13260).
- D. Background and Rationale for Requirements.** The Regional Water Board developed the requirements in this Order based on information submitted as part of the application, through monitoring and reporting programs, and other available information. The Fact Sheet (Attachment F), which contains background information and rationale for Order requirements, is hereby incorporated into this Order and constitutes part of the Findings for this Order. Attachments A through E are also incorporated into this Order.
- E. California Environmental Quality Act (CEQA).** Under Water Code section 13389, this action to adopt an NPDES permit is exempt from the provisions of CEQA, Public Resources Code sections 21100-21177.
- F. Technology-based Effluent Limitations.** Section 301(b) of the CWA and implementing USEPA permit regulations at section 122.44, title 40 of the Code of Federal Regulations (CFR)¹ require that permits include conditions meeting applicable technology-based requirements at a minimum, and any more stringent effluent limitations necessary to meet applicable water quality standards. The discharge authorized by this Order must meet minimum federal technology-based requirements based on Effluent Limitations Guidelines and Standards for the Timber Products Processing Point Source Category, Wet Storage Subcategory (40 CFR Part 429, Subpart I). There is currently no discharge from the log deck, therefore there are no effluent limits set for the log deck. All log deck water is recycled for use on the log deck with no discharge. 40 CFR Part 432 (Steam Electric Power Generating Point Source Category) does not apply to this facility, since 40 CFR Part 423 is applicable to discharges resulting from the operation of a generating unit primarily engaged in distribution and sale of electricity from processes utilizing fossil-type fuel (coal, oil, or gas) or nuclear fuel. A detailed discussion of the technology-based effluent limitations development is included in the Fact Sheet (Attachment F).
- G. Water Quality-based Effluent Limitations.** Section 301(b) of the CWA and section 122.44(d) require that permits include limitations more stringent than applicable federal technology-based requirements where necessary to achieve applicable water quality standards. This Order contains requirements, expressed as a technology equivalence requirement, more stringent than secondary treatment requirements that are necessary

¹ All further statutory references are to title 40 of the Code of Federal Regulations unless otherwise indicated.

to meet applicable water quality standards. The Regional Water Board has considered the factors listed in CWC Section 13241 in establishing these requirements. The rationale for these requirements, which consist of tertiary treatment or equivalent requirements, is discussed in the Fact Sheet.

Section 122.44(d)(1)(i) mandates that permits include effluent limitations for all pollutants that are or may be discharged at levels that have the reasonable potential to cause or contribute to an exceedance of a water quality standard, including numeric and narrative objectives within a standard. Where reasonable potential has been established for a pollutant, but there is no numeric criterion or objective for the pollutant, water quality-based effluent limitations (WQBELs) must be established using: (1) EPA criteria guidance under CWA section 304(a), supplemented where necessary by other relevant information; (2) an indicator parameter for the pollutant of concern; or (3) a calculated numeric water quality criterion, such as a proposed State criterion or policy interpreting the State's narrative criterion, supplemented with other relevant information, as provided in 40 CFR section 122.44(d)(1)(vi).

Also as specified in Section 122.44(K), best management practices (BMPs) may be used in lieu of numeric effluent limitations when:

1. authorized under section 304(e) of the CWA for control of toxic pollutants and hazardous substances from ancillary industrial activities;
2. authorized under section 402(p) of the CWA for the control of storm water discharges;
3. numeric effluent limitations are infeasible; or
4. the practices are reasonably necessary to achieve effluent limitations and standards or to carry out the purpose and intent of the CWA.

Section 402(p) authorizes regulation of storm water discharges associated with industrial activities. A combination of BMPs, numeric effluent limitations, and receiving water limitations are utilized in this Order to regulate the discharge of pollutants from the Discharger's Facility.

H. Water Quality Control Plans. The Regional Water Board adopted a *Water Quality Control Plan, Fourth Edition (Revised August 2006), for the Sacramento and San Joaquin River* (hereinafter Basin Plan) that designates beneficial uses, establishes water quality objectives, and contains implementation programs and policies to achieve those objectives for all waters addressed through the plan. The Basin Plan at page II-2.00 states that the "...beneficial uses of any specifically identified water body generally apply to its tributary streams." The Basin Plan does not specifically identify beneficial uses for Stover Ditch, but does identify present and potential uses for Lake Almanor, to which Stover Ditch, is tributary. These surface water beneficial uses are as follows: hydropower generation; water contact recreation, including canoeing and rafting; warm freshwater habitat; cold freshwater habitat; warm spawning, reproduction, and/or early

development; and wildlife habitat. Unless otherwise designated by the Regional Water Board, all groundwaters in the Region are considered as suitable or potentially suitable, at a minimum, for municipal and domestic water supply, agricultural supply, industrial service supply and industrial process supply.

In addition, the Basin Plan implements State Water Resources Control Board (State Water Board) Resolution No. 88-63, which established state policy that all waters, with certain exceptions, should be considered suitable or potentially suitable for municipal or domestic supply. Thus, as discussed in detail in the Fact Sheet, beneficial uses applicable to **Stover Ditch** are as follows:

Table 5. Basin Plan Beneficial Uses

| Discharge Point | Receiving Water Name | Beneficial Use(s) |
|-----------------|---|--|
| 001 | Stover Ditch (tributary to Lake Almanor) | <p><u>Existing:</u> Hydropower generation (PWR); water contact recreation (REC-1); warm freshwater habitat (WARM); cold freshwater habitat (COLD); warm water spawning (SPWN); and wildlife habitat (WILD).</p> <p><u>Potential:</u> Municipal and domestic water supply (MUN).</p> <p><u>Groundwater:</u> Municipal and domestic water supply (MUN); agricultural supply (AGR); industrial service supply (IND); and industrial process supply (PRO).</p> |

I. National Toxics Rule (NTR) and California Toxics Rule (CTR). USEPA adopted the NTR on December 22, 1992, and later amended it on May 4, 1995 and November 9, 1999. About forty criteria in the NTR applied in California. On May 18, 2000, USEPA adopted the CTR. The CTR promulgated new toxics criteria for California and, in addition, incorporated the previously adopted NTR criteria that were applicable in the state. The CTR was amended on February 13, 2001. These rules contain water quality criteria for priority pollutants.

J. State Implementation Policy. On March 2, 2000, the State Water Board adopted the *Policy for Implementation of Toxics Standards for Inland Surface Waters, Enclosed Bays, and Estuaries of California* (State Implementation Policy or SIP). The SIP became effective on April 28, 2000 with respect to the priority pollutant criteria promulgated for California by the USEPA through the NTR and to the priority pollutant objectives established by the Regional Water Board in the Basin Plan. The SIP became effective on May 18, 2000 with respect to the priority pollutant criteria promulgated by the USEPA through the CTR. The State Water Board adopted amendments to the SIP on February 24, 2005 that became effective on July 13, 2005. The SIP establishes implementation provisions for priority pollutant criteria and objectives and provisions for chronic toxicity control. Requirements of this Order implement the SIP.

K. Compliance Schedules and Interim Requirements. In general, an NPDES permit must include final effluent limitations that are consistent with Clean Water Act section

301 and with 40 CFR 122.44(d). There are exceptions to this general rule. The State Water Board has concluded that where the Regional Water Board's Basin Plan allows for schedules of compliance and the Regional Water Board is newly interpreting a narrative standard, it may include schedules of compliance in the permit to meet effluent limits that implement a narrative standard. See *In the Matter of Waste Discharge Requirements for Avon Refinery* (State Board Order WQ 2001-06 at pp. 53-55). See also *Communities for a Better Environment et al. v. State Water Resources Control Board*, 34 Cal.Rptr.3d 396, 410 (2005). The Basin Plan for the Sacramento and San Joaquin Rivers includes a provision that authorizes the use of compliance schedules in NPDES permits for water quality objectives that are adopted after the date of adoption of the Basin Plan, which was September 25, 1995 (See Basin Plan at page IV-16). Consistent with the State Water Board's Order in the CBE matter, the Regional Water Board has the discretion to include compliance schedules in NPDES permits when it is including an effluent limitation that is a "new interpretation" of a narrative water quality objective. This conclusion is also consistent with the United States Environmental Protection Agency policies and administrative decisions. See, e.g., Whole Effluent Toxicity (WET) Control Policy. The Regional Water Board, however, is not required to include a schedule of compliance, but may issue a Time Schedule Order pursuant to Water Code section 13300 or a Cease and Desist Order pursuant to Water Code section 13301 where it finds that the discharger is violating or threatening to violate the permit. The Regional Water Board will consider the merits of each case in determining whether it is appropriate to include a compliance schedule in a permit, and, consistent with the Basin Plan, should consider feasibility of achieving compliance, and must impose a schedule that is as short as practicable to achieve compliance with the objectives, criteria, or effluent limit based on the objective or criteria.

For CTR constituents, Section 2.1 of the SIP provides that, based on a Discharger's request and demonstration that it is infeasible for an existing Discharger to achieve immediate compliance with an effluent limitation derived from a CTR criterion, compliance schedules may be allowed in an NPDES permit. Unless an exception has been granted under section 5.3 of the SIP, a compliance schedule may not exceed 5 years from the date that the permit is issued or reissued, nor may it extend beyond 10 years from the effective date of the SIP (or May 18, 2010) to establish and comply with CTR criterion-based effluent limitations. Where a compliance schedule for a final effluent limitation that exceeds 1 year, the Order must include interim numeric limitations for that constituent or parameter. Where allowed by the Basin Plan, compliance schedules and interim effluent limitations or discharge specifications may also be granted to allow time to implement a new or revised water quality objective. This Order does include compliance schedules and interim effluent limitations and/or discharge specifications. A detailed discussion of the basis for the compliance schedule(s) and interim effluent limitation(s) and/or discharge specifications is included in the Fact Sheet.

- L. Alaska Rule.** On March 30, 2000, USEPA revised its regulation that specifies when new and revised state and tribal water quality standards (WQS) become effective for CWA purposes. (40 C.F.R. § 131.21; 65 Fed. Reg. 24641 (April 27, 2000).) Under the revised regulation (also known as the Alaska rule), new and revised standards

submitted to USEPA after May 30, 2000, must be approved by USEPA before being used for CWA purposes. The final rule also provides that standards already in effect and submitted to USEPA by May 30, 2000 may be used for CWA purposes, whether or not approved by USEPA.

M. Stringency of Requirements for Individual Pollutants. This Order contains both technology-based and water quality-based effluent limitations for individual pollutants. The technology-based effluent limitations consist of restrictions on pH. The water quality-based effluent limitations consist of restrictions on suspended solids, settleable solids, specific conductance and chemical oxygen demand. This Order's technology-based pollutant restrictions implement the minimum, applicable federal technology-based requirements. In addition, this Order contains effluent limitations more stringent than the minimum, federal technology-based requirements that are necessary to meet water quality standards. These limitations are more stringent than required by the CWA. Specifically, this Order includes effluent limitations for suspended solids, settleable solids, specific conductance, chemical oxygen demand that are more stringent than applicable federal standards, but that are nonetheless necessary to meet numeric objectives or protect beneficial uses. The rationale for including these limitations is explained in the Fact Sheet. In addition, the Regional Water Board has considered the factors in Water Code section 13241 in establishing these requirements.

Water quality-based effluent limitations have been scientifically derived to implement water quality objectives that protect beneficial uses. Both the beneficial uses and the water quality objectives have been approved pursuant to federal law and are the applicable federal water quality standards. To the extent that toxic pollutant water quality-based effluent limitations were derived from the CTR, the CTR is the applicable standard pursuant to 40 CFR section 131.38. The scientific procedures for calculating the individual water quality-based effluent limitations are based on the CTR-SIP, which was approved by USEPA on May 1, 2001. All beneficial uses and water quality objectives contained in the Basin Plan were approved under state law and submitted to and approved by USEPA prior to May 30, 2000. Any water quality objectives and beneficial uses submitted to USEPA prior to May 30, 2000, but not approved by USEPA before that date, are nonetheless "*applicable water quality standards for purposes of the [Clean Water] Act*" pursuant to 40 CFR section 131.21(c)(1). Collectively, this Order's restrictions on individual pollutants are no more stringent than required to implement the technology-based requirements of the CWA and the applicable water quality standards for purposes of the CWA.

N. Antidegradation Policy. Section 131.12 requires that the state water quality standards include an antidegradation policy consistent with the federal policy. The State Water Board established California's antidegradation policy in State Water Board Resolution No. 68-16. Resolution No. 68-16 is consistent with the federal antidegradation policy where the federal policy applies under federal law. Resolution No. 68-16 requires that existing quality of waters be maintained unless degradation is justified based on specific findings. The Regional Water Board's Basin Plan implements, and incorporates by reference, both the state and federal antidegradation policies. As discussed in detail in

the Fact Sheet the permitted discharge is consistent with the antidegradation provision of section 131.12 and State Water Board Resolution No. 68-16.

- O. Anti-Backsliding Requirements.** Sections 402(o)(2) and 303(d)(4) of the CWA and federal regulations at title 40, Code of Federal Regulations section 122.44(l) prohibit backsliding in NPDES permits. These anti-backsliding provisions require effluent limitations in a reissued permit to be as stringent as those in the previous permit, with some exceptions where limitations may be relaxed. All effluent limitations in this Order are at least as stringent as the effluent limitations in the previous Order.
- P. Monitoring and Reporting.** Section 122.48 requires that all NPDES permits specify requirements for recording and reporting monitoring results. Water Code sections 13267 and 13383 authorizes the Regional Water Board to require technical and monitoring reports. The Monitoring and Reporting Program establishes monitoring and reporting requirements to implement federal and State requirements. This Monitoring and Reporting Program is provided in Attachment E.
- Q. Standard and Special Provisions.** Standard Provisions, which apply to all NPDES permits in accordance with section 122.41, and additional conditions applicable to specified categories of permits in accordance with section 122.42, are provided in Attachment D. The discharger must comply with all standard provisions and with those additional conditions that are applicable under section 122.42. The Regional Water Board has also included in this Order special provisions applicable to the Discharger. A rationale for the special provisions contained in this Order is provided in the attached Fact Sheet.
- R. Provisions and Requirements Implementing State Law.** The provisions/requirements in subsections IV.B, IV.C, V.B, and VI.C. of this Order are included to implement state law only. These provisions/requirements are not required or authorized under the federal CWA; consequently, violations of these provisions/requirements are not subject to the enforcement remedies that are available for NPDES violations.
- S. Notification of Interested Parties.** The Regional Water Board has notified the Discharger and interested agencies and persons of its intent to prescribe Waste Discharge Requirements for the discharge and has provided them with an opportunity to submit their written comments and recommendations. Details of notification are provided in the Fact Sheet of this Order.
- T. Consideration of Public Comment.** The Regional Water Board, in a public meeting, heard and considered all comments pertaining to the discharge. Details of the Public Hearing are provided in the Fact Sheet of this Order.

III. DISCHARGE PROHIBITIONS

- A. Discharge of wastewater at a location or in a manner different from that described in the Findings is prohibited.
- B. The by-pass or overflow of wastes to surface waters is prohibited, except as allowed by Federal Standard Provisions I.G. and I.H. (Attachment D).
- C. Neither the discharge nor its treatment shall create a nuisance as defined in Section 13050 of the California Water Code.
- D. The Discharger shall not allow pollutant-free wastewater to be discharged into the collection, treatment, and disposal system in amounts that significantly diminish the system's capability to comply with this Order. Pollutant-free wastewater means rainfall, groundwater, cooling waters, and condensates that are essentially free of pollutants.
- E. The discharge of waste that causes violation of any narrative water quality objective contained in the Basin Plan is prohibited.
- F. The discharge of waste that causes violation of any numeric water quality objective contained in the Basin Plan is prohibited.
- G. Where any numeric or narrative water quality objective contained in the Basin Plan is already being violated, the discharge of waste that causes further degradation or pollution is prohibited.
- H. The Discharger shall not cause pollution as defined in Section 13050 of the California Water Code.
- I. Discharge of storm water at a location or in a manner different from that described in the Findings is prohibited.
- J. The discharge of leachate from wood fuel stockpiles or ash stockpiles to surface waters, surface water drainage courses, or groundwater is prohibited.
- K. The discharge of hazardous or toxic substances, including water treatment chemicals, solvents, or petroleum products (including oil, grease, gasoline and diesel) to surface waters or groundwater is prohibited.
- L. The discharge of ash, bark, sawdust, wood, debris, or any other wastes recognized as originating from the facility to surface waters or surface water drainage courses is prohibited.

IV. EFFLUENT LIMITATIONS AND DISCHARGE SPECIFICATIONS

A. Effluent Limitations – Discharge Point EFF-001

1. Final Effluent Limitations – Discharge Point EFF-001

The Discharger shall maintain compliance with the following effluent limitations at Discharge Point EFF-001, with compliance measured at Monitoring Location EFF-001 as described in the attached MRP (Attachment E):

- a. The Discharger shall maintain compliance with the effluent limitations specified in Table 6:

Table 6. Effluent Limitations

| Parameter | Units | Effluent Limitations | | | | |
|---------------------------|----------|----------------------|----------------|---------------|------------------|------------------|
| | | Average Monthly | Average Weekly | Maximum Daily | Instant. Minimum | Instant. Maximum |
| Average Dry Weather Flow | mgd | 0.36 | -- | -- | -- | -- |
| Suspended Solids | mg/L | -- | -- | 40 | -- | -- |
| Settleable Solids | mL/L | 0.1 | -- | 0.2 | -- | -- |
| Specific Conductance | umhos/cm | -- | -- | 900 | -- | -- |
| Chemical Oxygen Demand | mg/L | -- | -- | 40 | -- | -- |
| pH | -- | -- | -- | -- | 6.0 | 9.0 |
| Copper, Total Recoverable | ug/L | 7.44 | -- | 14.92 | -- | -- |
| Lead, Total Recoverable | ug/L | 2.95 | -- | 5.92 | -- | -- |

- b. **Acute Whole Effluent Toxicity.** Survival of aquatic organisms in 96-hour bioassays of undiluted waste shall be no less than:
 - i. 70%, minimum for any one bioassay; and
 - ii. 90%, median for any three consecutive bioassays.
- c. **Average Daily Discharge Flow.** The Average Daily Discharge Flow shall not exceed 0.36 mgd.
- d. **Chronic Whole Effluent Toxicity.** There shall be no chronic toxicity in the effluent discharge.

2. Interim Effluent Limitations

- a. During the period beginning **February 5, 2009** and ending on **May 17, 2010**, the Discharger shall maintain compliance with the following limitations at Discharge Point EFF-001 with compliance measured at Monitoring Location EFF-001 as described in the attached MRP. These interim effluent limitations shall apply in lieu of the corresponding final effluent limitations specified for the same parameters during the time period indicated in this provision.

Table 7. Interim Effluent Limitations

| Parameter | Units | Effluent Limitations | | | | |
|-----------|-------|----------------------|----------------|---------------|-----------------------|-----------------------|
| | | Average Monthly | Average Weekly | Maximum Daily | Instantaneous Minimum | Instantaneous Maximum |
| Copper | µg/L | -- | -- | 31.16 | -- | -- |
| Lead | µg/L | -- | -- | 8.74 | -- | -- |

B. Land Discharge Specifications – Not Applicable

C. Reclamation Specifications – Not Applicable

V. RECEIVING WATER LIMITATIONS

A. Surface Water Limitations

Receiving water limitations are based on water quality objectives contained in the Basin Plan and are a required part of this Order. The discharge shall not cause the following in Stover Ditch, a tributary to Lake Almanor:

1. **Biostimulatory Substances.** Water to contain biostimulatory substances which promote aquatic growths in concentrations that cause nuisance or adversely affect beneficial uses.
2. **Chemical Constituents.** Chemical constituents to be present in concentrations that adversely affect beneficial uses.
3. **Color.** Discoloration that causes nuisance or adversely affects beneficial uses.
4. **Dissolved Oxygen:**
 - a. The monthly median of the mean daily dissolved oxygen concentration to fall below 85 percent of saturation in the main water mass;
 - b. The 95 percentile dissolved oxygen concentration to fall below 75 percent of saturation; nor
 - c. The dissolved oxygen concentration to be reduced below 7.0 mg/L at any time.
5. **Floating Material.** Floating material to be present in amounts that cause nuisance or adversely affect beneficial uses.
6. **Oil and Grease.** Oils, greases, waxes, or other materials to be present in concentrations that cause nuisance, result in a visible film or coating on the surface of the water or on objects in the water, or otherwise adversely affect beneficial uses
7. **pH.** The pH to be depressed below 6.5, raised above 8.5, nor changed by more than 0.5 units. A one-month averaging period may be applied when calculating the pH change of 0.5 units.)
8. **Pesticides:**
 - a. Pesticides to be present, individually or in combination, in concentrations that adversely affect beneficial uses;
 - b. Pesticides to be present in bottom sediments or aquatic life in concentrations that adversely affect beneficial uses;
 - c. Total identifiable persistent chlorinated hydrocarbon pesticides to be present in the water column at concentrations detectable within the accuracy of analytical methods approved by USEPA or the Executive Officer/prescribed in *Standard*

Methods for the Examination of Water and Wastewater, 18th Edition, or other equivalent methods approved by the Executive Officer.

- d. Pesticide concentrations to exceed those allowable by applicable antidegradation policies (see State Water Board Resolution No. 68-16 and 40 CFR §131.12.).
- e. Pesticide concentrations to exceed the lowest levels technically and economically achievable.
- f. Pesticides to be present in concentration in excess of the maximum contaminant levels set forth in California Code of Regulations, Title 22, Division 4, Chapter 15/specified in Table 64444-A (Organic Chemicals) of Section 64444 of Title 22 of the California Code of Regulations.
- g. Thiobencarb to be present in excess of 1.0 µg/L.

9. Radioactivity:

- a. Radionuclides to be present in concentrations that are harmful/deleterious to human, plant, animal, or aquatic life nor that result in the accumulation of radionuclides in the food web to an extent that presents a hazard to human, plant, animal, or aquatic life.
- b. Radionuclides to be present in excess of the maximum contaminant levels specified in Table 4 (MCL Radioactivity) of Section 64443 of Title 22 of the California Code of Regulations.

10. Suspended Sediments. The suspended sediment load and suspended sediment discharge rate of surface waters to be altered in such a manner as to cause nuisance or adversely affect beneficial uses.

11. Settleable Substances. Substances to be present in concentrations that result in the deposition of material that causes nuisance or adversely affects beneficial uses.

12. Suspended Material. Suspended material to be present in concentrations that cause nuisance or adversely affect beneficial uses.

13. Taste and Odors. Taste- or odor-producing substances to be present in concentrations that impart undesirable tastes or odors to fish flesh or other edible products of aquatic origin, or that cause nuisance, or otherwise adversely affect beneficial uses/or to domestic or municipal water supplies.

14. Temperature. The natural temperature to be increased by more than 5°F.

15. Toxicity. Toxic substances to be present, individually or in combination, in concentrations that produce detrimental physiological responses in human, plant, animal, or aquatic life.

16. Turbidity. The turbidity to increase as follows:

- a. More than 1 Nephelometric Turbidity Unit (NTU) where natural turbidity is between 0 and 5 NTUs.

- b. More than 20 percent where natural turbidity is between 5 and 50 NTUs.
- c. More than 10 NTU where natural turbidity is between 50 and 100 NTUs.
- d. More than 10 percent where natural turbidity is greater than 100 NTUs.

B. Groundwater Limitations

1. The discharge shall not cause the underlying groundwater to be degraded.
2. Release of waste constituents from any storage, treatment, or disposal component associated with the facility shall not, in combination with other sources of the waste constituents, cause groundwater within influence of the facility to contain waste constituents in concentrations in excess of natural background quality or that listed below, whichever is greater:
 - a. Chemical constituents in concentrations that adversely affect beneficial uses;
 - b. Exhibit a pH of less than 6.5 or greater than 8.5 pH units;
 - c. Impart taste, odor, toxicity, or color that creates nuisance or impairs any beneficial use.

VI. PROVISIONS

A. Standard Provisions

1. The Discharger shall comply with all Standard Provisions included in Attachment D of this Order.
2. The Discharger shall comply with the following provisions:
 - a. After notice and opportunity for a hearing, this Order may be terminated or modified for cause, including, but not limited to:
 - i. violation of any term or condition contained in this Order;
 - ii. obtaining this Order by misrepresentation or by failing to disclose fully all relevant facts;
 - iii. a change in any condition that requires either a temporary or permanent reduction or elimination of the authorized discharge; and
 - iv. a material change in the character, location, or volume of discharge.

The causes for modification include:

- *New regulations.* New regulations have been promulgated under Section 405(d) of the Clean Water Act, or the standards or regulations on which the permit was based have been changed by promulgation of amended standards or regulations or by judicial decision after the permit was issued.

- *Land application plans.* When required by a permit condition to incorporate a land application plan for beneficial reuse of sewage sludge, to revise an existing land application plan, or to add a land application plan.
- *Change in sludge use or disposal practice.* Under 40 Code of Federal Regulations (CFR) 122.62(a)(1), a change in the Discharger's sludge use or disposal practice is a cause for modification of the permit. It is cause for revocation and reissuance if the Discharger requests or agrees.

The Regional Water Board may review and revise this Order at any time upon application of any affected person or the Regional Water Board's own motion.

- b. If a toxic effluent standard or prohibition (including any scheduled compliance specified in such effluent standard or prohibition) is established under Section 307(a) of the CWA, or amendments thereto, for a toxic pollutant that is present in the discharge authorized herein, and such standard or prohibition is more stringent than any limitation upon such pollutant in this Order, the Regional Water Board will revise or modify this Order in accordance with such toxic effluent standard or prohibition.

The Discharger shall comply with effluent standards and prohibitions within the time provided in the regulations that establish those standards or prohibitions, even if this Order has not yet been modified.

- c. This Order shall be modified, or alternately revoked and reissued, to comply with any applicable effluent standard or limitation issued or approved under Sections 301(b)(2)(C) and (D), 304(b)(2), and 307(a)(2) of the CWA, if the effluent standard or limitation so issued or approved:
 - i. contains different conditions or is otherwise more stringent than any effluent limitation in the Order; or
 - ii. controls any pollutant limited in the Order.

The Order, as modified or reissued under this paragraph, shall also contain any other requirements of the CWA then applicable.

- d. The provisions of this Order are severable. If any provision of this Order is found invalid, the remainder of this Order shall not be affected.
- e. The Discharger shall take all reasonable steps to minimize any adverse effects to waters of the State or users of those waters resulting from any discharge or sludge use or disposal in violation of this Order. Reasonable steps shall include such accelerated or additional monitoring as necessary to determine the nature and impact of the non-complying discharge or sludge use or disposal.

- f. The Discharger shall ensure compliance with any existing or future pretreatment standard promulgated by USEPA under Section 307 of the CWA, or amendment thereto, for any discharge to the municipal system.
- g. The discharge of any radiological, chemical or biological warfare agent or high-level, radiological waste is prohibited.
- h. A copy of this Order shall be maintained at the discharge facility and be available at all times to operating personnel. Key operating personnel shall be familiar with its content.
- i. Safeguard to electric power failure:
 - i. The Discharger shall provide safeguards to assure that, should there be reduction, loss, or failure of electric power, the discharge shall comply with the terms and conditions of this Order.
 - ii. Upon written request by the Regional Water Board the Discharger shall submit a written description of safeguards. Such safeguards may include alternate power sources, standby generators, retention capacity, operating procedures, or other means. A description of the safeguards provided shall include an analysis of the frequency, duration, and impact of power failures experienced over the past five years on effluent quality and on the capability of the Discharger to comply with the terms and conditions of the Order. The adequacy of the safeguards is subject to the approval of the Regional Water Board.
 - iii. Should the treatment works not include safeguards against reduction, loss, or failure of electric power, or should the Regional Water Board not approve the existing safeguards, the Discharger shall, within ninety days of having been advised in writing by the Regional Water Board that the existing safeguards are inadequate, provide to the Regional Water Board and USEPA a schedule of compliance for providing safeguards such that in the event of reduction, loss, or failure of electric power, the Discharger shall comply with the terms and conditions of this Order. The schedule of compliance shall, upon approval of the Regional Water Board, become a condition of this Order.
- j. The Discharger, upon written request of the Regional Water Board, shall file with the Board a technical report on its preventive (failsafe) and contingency (cleanup) plans for controlling accidental discharges, and for minimizing the effect of such events. This report may be combined with that required under Regional Water Board Standard Provision VI.A.2.m.

The technical report shall:

- i. Identify the possible sources of spills, leaks, untreated waste by-pass, and contaminated drainage. Loading and storage areas, power outage, waste

treatment unit outage, and failure of process equipment, tanks and pipes should be considered.

- ii. Evaluate the effectiveness of present facilities and procedures and state when they became operational.
- iii. Predict the effectiveness of the proposed facilities and procedures and provide an implementation schedule containing interim and final dates when they will be constructed, implemented, or operational.

The Regional Water Board, after review of the technical report, may establish conditions which it deems necessary to control accidental discharges and to minimize the effects of such events. Such conditions shall be incorporated as part of this Order, upon notice to the Discharger.

- k. If the waste flow has been increasing, or is projected to increase, the Discharger shall estimate when flows will reach hydraulic and treatment capacities of its treatment and disposal facilities. The projections shall be made in January, based on the last three years' average dry weather flows, peak wet weather flows and total annual flows, as appropriate. When any projection shows that capacity of any part of the facilities may be exceeded in four years, the Discharger shall notify the Regional Water Board by 31 January. A copy of the notification shall be sent to appropriate local elected officials, local permitting agencies and the press. Within 120 days of the notification, the Discharger shall submit a technical report showing how it will prevent flow volumes from exceeding capacity or how it will increase capacity to handle the larger flows. The Regional Water Board may extend the time for submitting the report.
- l. The Discharger shall submit technical reports as directed by the Executive Officer. All technical reports required herein that involve planning, investigation, evaluation, or design, or other work requiring interpretation and proper application of engineering or geologic sciences, shall be prepared by or under the direction of persons registered to practice in California pursuant to California Business and Professions Code, sections 6735, 7835, and 7835.1. To demonstrate compliance with Title 16, CCR, sections 415 and 3065, all technical reports must contain a statement of the qualifications of the responsible registered professional(s). As required by these laws, completed technical reports must bear the signature(s) and seal(s) of the registered professional(s) in a manner such that all work can be clearly attributed to the professional responsible for the work.
- m. Laboratories that perform sample analyses must be identified in all monitoring reports submitted to the Regional Water Board.
- n. Effluent samples shall be taken downstream of the last addition of wastes to the treatment or discharge works where a representative sample may be obtained prior to mixing with the receiving waters. Samples shall be collected at such a point and in such a manner to ensure a representative sample of the discharge.

- o. All monitoring and analysis instruments and devices used by the Discharger to fulfill the prescribed monitoring program shall be properly maintained and calibrated as necessary, at least yearly, to ensure their continued accuracy.
- p. The Discharger shall file with the Regional Water Board technical reports on self-monitoring performed according to the detailed specifications contained in the Monitoring and Reporting Program attached to this Order.
- q. The results of all monitoring required by this Order shall be reported to the Regional Water Board, and shall be submitted in such a format as to allow direct comparison with the limitations and requirements of this Order. Unless otherwise specified, discharge flows shall be reported in terms of the monthly average and the daily maximum discharge flows.
- r. The Regional Water Board is authorized to enforce the terms of this permit under several provisions of the CWC, including, but not limited to, sections 13385, 13386, and 13387.
- s. Prior to making any change in the point of discharge, place of use, or purpose of use of treated wastewater that results in a decrease of flow in any portion of a watercourse, the Discharger must file a petition with the State Water Board, Division of Water Rights, and receive approval for such a change. (CWC section 1211).
- t. In the event the Discharger does not comply or will be unable to comply for any reason, with any prohibition, maximum daily effluent limitation, 1-hour average effluent limitation, or receiving water limitation contained in this Order, the Discharger shall notify the Regional Water Board by telephone (530) 224-4845 within 24 hours of having knowledge of such noncompliance, and shall confirm this notification in writing within five days, unless the Regional Water Board waives confirmation. The written notification shall include the information required by Attachment D, Section V.E.1 [40 CFR section 122.41(l)(6)(i)].

B. Monitoring and Reporting Program (MRP) Requirements

- 1. The Discharger shall comply with the MRP, and future revisions thereto, in Attachment E of this Order.

C. Special Provisions

1. Reopener Provisions

- a. This Order may be reopened for modification, or revocation and reissuance, as a result of the detection of a reportable priority pollutant generated by special conditions included in this Order. These special conditions may be, but are not limited to, fish tissue sampling, whole effluent toxicity, monitoring requirements on internal waste stream(s), and monitoring for surrogate parameters. Additional

requirements may be included in this Order as a result of the special condition monitoring data.

- b. Conditions that necessitate a major modification of a permit are described in 40 CFR section 122.62, including:
 - i. If new or amended applicable water quality standards are promulgated or approved pursuant to Section 303 of the CWA, or amendments thereto, this permit may be reopened and modified in accordance with the new or amended standards.
 - ii. When new information, that was not available at the time of permit issuance, would have justified different permit conditions at the time of issuance.
- c. **Mercury.** If mercury is found to be causing toxicity based on acute or chronic toxicity test results, or if a TMDL program is adopted, this Order shall be reopened and the interim mass effluent limitation modified (higher or lower) or an effluent concentration limitation imposed. If the Regional Water Board determines that a mercury offset program is feasible for Dischargers subject to a NPDES permit, then this Order may be reopened to reevaluate the interim mercury mass loading limitation(s) and the need for a mercury offset program for the Discharger.
- d. **Pollution Prevention.** This Order requires the Discharger prepare pollution prevention plans following CWC section 13263.3(d)(3) for copper and lead. Based on a review of the pollution prevention plans, this Order may be reopened for addition and/or modification of effluent limitations and requirements for these constituents.
- e. **Whole Effluent Toxicity.** As a result of a Toxicity Reduction Evaluation (TRE), this Order may be reopened to include a chronic toxicity limitation, a new acute toxicity limitation, and/or a limitation for a specific toxicant identified in the TRE. Additionally, if the State Water Board revises the SIP's toxicity control provisions that would require the establishment of numeric chronic toxicity effluent limitations, this Order may be reopened to include a numeric chronic toxicity effluent limitation based on the new provisions.
- f. **Water Effects Ratios (WER) and Metal Translators.** A default WER of 1.0 has been used in this Order for calculating CTR criteria for applicable priority pollutant inorganic constituents. In addition, default dissolved-to-total metal translators have been used to convert water quality objectives from dissolved to total recoverable when developing effluent limitations for copper and lead. If the Discharger performs studies to determine site-specific WERs and/or site-specific dissolved-to-total metal translators, this Order may be reopened to modify the effluent limitations for the applicable inorganic constituents.
- g. **Constituent Study.** If after review of the study results it is determined that the discharge has reasonable potential to cause or contribute to an exceedance of a

water quality objective this Order may be reopened and effluent limitations added for the subject constituents.

- h. **Total Maximum Daily Loads (TMDL).** This Order may be reopened and modified as necessary to implement any TMDLs that are adopted or modified and are applicable to the receiving water.
- i. **Mixing Zone – Dilution Study.** The Discharger has the option of conducting a Mixing Zone/Dilution Study, which can be used by the Regional Board in calculating effluent limitations, based on priority pollutant sample results. Regarding mixing zones, the SIP states, “*A mixing zone shall be as small as practicable. The following conditions must be met in allowing a mixing zone:*

A: A mixing zone shall not:

- (1) compromise the integrity of the entire water body;*
- (2) cause acutely toxic conditions to aquatic life passing through the mixing zone;*
- (3) restrict the passage of aquatic life;*
- (4) adversely impact biologically sensitive or critical habitats, including, but not limited to, habitat of species listed under federal or State endangered species laws;*
- (5) produce undesirable or nuisance aquatic life;*
- (6) result in floating debris, oil, or scum;*
- (7) produce objectionable color, odor, taste, or turbidity;*
- (8) cause objectionable bottom deposits;*
- (9) cause nuisance;*
- (10) dominate the receiving water body or overlap a mixing zone from different outfalls; or*
- (11) be allowed at or near any drinking water intake. A mixing zone is not a source of drinking water. To the extent of any conflict between this determination and the Sources of Drinking Water Policy (Resolution No. 88-63), this SIP supersedes the provisions of that policy.”*

2. Special Studies, Technical Reports and Additional Monitoring Requirements

- a. **Chronic Whole Effluent Toxicity.** For compliance with the Basin Plan’s narrative toxicity objective, this Order requires the Discharger to conduct chronic whole effluent toxicity testing, as specified in the Monitoring and Reporting Program (Attachment E, Section V.). Furthermore, this Provision requires the Discharger to investigate the causes of, and identify corrective actions to reduce or eliminate effluent toxicity. If the discharge exceeds the toxicity numeric monitoring trigger established in this Provision, the Discharger is required to

initiate a Toxicity Reduction Evaluation (TRE), in accordance with an approved TRE Work Plan, and take actions to mitigate the impact of the discharge and prevent reoccurrence of toxicity. A TRE is a site-specific study conducted in a stepwise process to identify the source(s) of toxicity and the effective control measures for effluent toxicity. TREs are designed to identify the causative agents and sources of whole effluent toxicity, evaluate the effectiveness of the toxicity control options, and confirm the reduction in effluent toxicity. This Provision includes requirements for the Discharger to develop and submit a TRE Work Plan and includes procedures for accelerated chronic toxicity monitoring and TRE initiation.

- i. **Toxicity Reduction Evaluation (TRE) Work Plan. Within 90 days of the effective date of this Order**, the Discharger shall submit to the Regional Water Board a Revised TRE Work Plan for approval by the Executive Officer. The Discharger submitted a TIE/TRE Testing Requirements/Proposal on 7 July 2004. The Revised TRE Work Plan should be updated and should include, at minimum:
 - a) A description of the investigation and evaluation techniques that will be used to identify potential causes and sources of effluent toxicity, effluent variability, and treatment system efficiency;
 - b) A description of the facility's methods of maximizing in-house treatment efficiency and good housekeeping practices, and a list of all chemicals used in operation of the facility; and
 - c) A discussion of who will conduct the Toxicity Identification Evaluation, if necessary (i.e. an in-house expert or outside contractor).
- ii. **Accelerated Monitoring and TRE Initiation.** When the numeric toxicity monitoring trigger is exceeded during regular chronic toxicity monitoring, and the testing meets all test acceptability criteria, the Discharger shall initiate accelerated monitoring as required in the Accelerated Monitoring Specifications. WET testing results exceeding the monitoring trigger during accelerated monitoring demonstrates a pattern of toxicity and requires the Discharger to initiate a TRE to address the effluent toxicity.
- iii. **Numeric Monitoring Trigger.** The numeric toxicity monitoring trigger is $> 1 \text{ TUc}$ (where $\text{TUc} = 100/\text{NOEC}$). The monitoring trigger is not an effluent limitation; it is the toxicity threshold at which the Discharger is required to begin accelerated monitoring and initiate a TRE.
- iv. **Accelerated Monitoring Specifications.** If the monitoring trigger is exceeded during regular chronic toxicity testing, within 14-days of notification by the laboratory of the test results, the Discharger shall initiate accelerated monitoring. Accelerated monitoring shall consist of four (4) chronic toxicity tests in a six-week period (i.e. one test every two weeks) using the species

that exhibited toxicity. The following protocol shall be used for accelerated monitoring and TRE initiation:

- a) If the results of four (4) consecutive accelerated monitoring tests do not exceed the monitoring trigger, the Discharger may cease accelerated monitoring and resume regular chronic toxicity monitoring. However, notwithstanding the accelerated monitoring results, if there is adequate evidence of a pattern of effluent toxicity, the Executive Officer may require that the Discharger initiate a TRE.
 - b) If the source(s) of the toxicity is easily identified (i.e. temporary plant upset), the Discharger shall make necessary corrections to the facility and shall continue accelerated monitoring until four (4) consecutive accelerated tests do not exceed the monitoring trigger. Upon confirmation that the effluent toxicity has been removed, the Discharger may cease accelerated monitoring and resume regular chronic toxicity monitoring.
 - c) If the result of any accelerated toxicity test exceeds the monitoring trigger, the Discharger shall cease accelerated monitoring and initiate a TRE to investigate the cause(s) of, and identify corrective actions to reduce or eliminate effluent toxicity. Within thirty (30) days of notification by the laboratory of the test results exceeding the monitoring trigger during accelerated monitoring, the Discharger shall submit a TRE Action Plan to the Regional Water Board including, at minimum:
 - 1) Specific actions the Discharger will take to investigate and identify the cause(s) of toxicity, including TRE WET monitoring schedule;
 - 2) Specific actions the Discharger will take to mitigate the impact of the discharge and prevent the recurrence of toxicity; and
 - 3) A schedule for these actions.
- b. **Constituent Study.** There are indications that the discharge may contain constituents that have a reasonable potential to cause or contribute to an exceedance of water quality objectives: copper and lead. The Discharger shall comply with the following time schedule in conducting a study of these constituents' potential effect in surface waters:

Table 8. Constituent Study – Copper and Lead

| Task | Compliance Date |
|---------------------------------------|--|
| 1 - Submit Workplan and Time Schedule | Within 6 months of the effective date of Order |
| 2 - Begin Study | Within 3 months of Regional Board approval of Workplan and Time Schedule |
| 3 - Complete Study | As established by Task 1 |
| 4 - Submit Study Report | 60 days following completion of Task 3 |

c. **BPTC Evaluation Tasks.** The Discharger has submitted a BPTC plan for the facility, dated 27 January 2006, as required by Resolution 68-16.

3. Best Management Practices and Pollution Prevention

a. **Pollutant Minimization Program.** The Discharger shall develop and conduct a Pollutant Minimization Program (PMP) as further described below when there is evidence (e.g., sample results reported as DNQ when the effluent limitation is less than the MDL, sample results from analytical methods more sensitive than those methods required by this Order, presence of whole effluent toxicity, health advisories for fish consumption, results of benthic or aquatic organism tissue sampling) that a priority pollutant is present in the effluent above an effluent limitation and either: 1) A sample result is reported as DNQ and the effluent limitation is less than the RL; or 2) A sample result is reported as ND and the effluent limitation is less than the MDL, using definitions described in Attachment A and reporting protocols described in MRP section X.A.4.

The PMP shall include, but not be limited to, the following actions and submittals acceptable to the Regional Water Board:

- i. An annual review and semi-annual monitoring of potential sources of the reportable priority pollutant(s), which may include fish tissue monitoring and other bio-uptake sampling;
- ii. Quarterly monitoring for the reportable priority pollutant(s) in the influent to the wastewater treatment system;
- iii. Submittal of a control strategy designed to proceed toward the goal of maintaining concentrations of the reportable priority pollutant(s) in the effluent at or below the effluent limitation;
- iv. Implementation of appropriate cost-effective control measures for the reportable priority pollutant(s), consistent with the control strategy; and

- v. An annual status report that shall be sent to the Regional Water Board including:
 - (1) All PMP monitoring results for the previous year;
 - (2) A list of potential sources of the reportable priority pollutant(s);
 - (3) A summary of all actions undertaken pursuant to the control strategy; and
 - (4) A description of actions to be taken in the following year.

- b. **Pollution Prevention Plan for Copper and Lead.** The Discharger shall prepare and implement a pollution prevention plan for copper and lead in accordance with CWC section 13263.3(d)(3). The minimum requirements for the pollution prevention plan are outlined in the Fact Sheet, Attachment F, Vii.B.3.b. A work plan and time schedule for preparation of the pollution prevention plan shall be completed and submitted **within 6 months of the effective date of this Order** for approval by the Executive Officer. The Pollution Prevention Plan shall be completed and submitted to the Regional Water Board **within one and one half (1 ½) years following work plan approval by the Executive Officer**, and progress reports shall be submitted in accordance with the Monitoring and Reporting Program (Attachment E, Section X.D.1.).

The Discharger shall comply with the following compliance schedule in implementing the work required by this Provision:

Table 9. Pollution Prevention Plan – Copper and Lead

| Task | Compliance Date |
|---------------------------------------|---|
| 1 - Submit Workplan and Time Schedule | Within 6 months of the effective date of Order |
| 2 - Begin Study | Within 3 months of Regional Board approval of Workplan and Time Schedule |
| 3 - Complete Study | As established by Task 1 |
| 4 - Submit Summary Report | 60 days following completion of Task 3 (no later than 1 ½ years after the effective date of this Order) |

Progress reports shall be submitted in accordance with the Monitoring and Reporting Program (Attachment E, Section X.D.1.).

- c. **Salinity Reduction Goal.** The Discharger shall provide annual reports demonstrating reasonable progress in the reduction of salinity in its discharge to Stover Ditch, a tributary to Lake Almanor. Based on the findings in the required

Salinity Evaluation and Minimization Plan, the Regional Water Board will set a reasonable goal (monthly average salinity as electrical conductivity) that can be achieved within the permit term. The annual reports shall be submitted in accordance with the Monitoring and Reporting Program (Attachment E, Section X.D.1.).

4. Construction, Operation and Maintenance Specifications

a. Treatment Pond Operating Requirements.

- i. The treatment facilities shall be designed, constructed, operated, and maintained to prevent inundation or washout due to floods with a 100-year return frequency.
- ii. Public contact with wastewater shall be precluded through such means as fences, signs, and other acceptable alternatives.
- iii. Ponds shall be managed to prevent breeding of mosquitoes. In particular,
 - a) An erosion control program should assure that small coves and irregularities are not created around the perimeter of the water surface.
 - b) Weeds shall be minimized.
 - c) Dead algae, vegetation, and debris shall not accumulate on the water surface.
- iv. Freeboard shall never be less than two feet (measured vertically to the lowest point of overflow), except if lesser freeboard does not threaten the integrity of the pond, no overflow of the pond occurs, and lesser freeboard is due to direct precipitation or storm water runoff occurring as a result of annual precipitation with greater than a 100-year recurrence interval, or a storm event with an intensity greater than a 25-year, 24-hour storm event.
- v. Ponds shall have sufficient capacity to accommodate allowable wastewater flow and design seasonal precipitation and ancillary inflow and infiltration during the non-irrigation season. Design seasonal precipitation shall be based on total annual precipitation using a return period of 100 years, distributed monthly in accordance with historical rainfall patterns. Freeboard shall never be less than two feet (measured vertically to the lowest point of overflow).

5. Special Provisions for Municipal Facilities (POTWs Only) – Not Applicable

6. Other Special Provisions

- a. In the event of any change in control or ownership of land or waste discharge facilities presently owned or controlled by the Discharger, the Discharger shall notify the succeeding owner or operator of the existence of this Order by letter, a

copy of which shall be immediately forwarded to the Regional Water Board.

To assume operation under this Order, the succeeding owner or operator must apply in writing to the Executive Officer requesting transfer of the Order. The request must contain the requesting entity's full legal name, the State of incorporation if a corporation, address and telephone number of the persons responsible for contact with the Regional Water Board and a statement. The statement shall comply with the signatory and certification requirements in the Federal Standard Provisions (Attachment D, Section V.B.) and state that the new owner or operator assumes full responsibility for compliance with this Order. Failure to submit the request shall be considered a discharge without requirements, a violation of the California Water Code. Transfer shall be approved or disapproved in writing by the Executive Officer.

b. Sludge, Wood Waste, and/or Ash Management.

1. Collected screenings, sludge, and other solids removed from liquid wastes shall be disposed of in a manner approved by the Executive Officer and consistent with *Consolidated Regulations for Treatment, Storage, Processing, or Disposal of Solid Waste*, as set forth in Title 27, California Code of Regulations (CCR), Division 2, Subdivision 1, Section 20005, et seq
2. Any proposed change in sludge or ash use or disposal practice shall be reported to the Executive Officer at least 30 days in advance of the change.
3. Fly ash removed from the facility shall be:
 - a. Beneficially reused, such as for soil amendment pursuant to an approved Ash Management Plan; or
 - b. Disposed in a dedicated unit consistent with Title 27, Section 20200(b); or
 - c. Disposed in a Class III landfill consistent with Title 27, Section 20220(d).

Any other use shall require approval by the Executive Officer.

c. Industrial Stormwater.

The current Order requires an industrial stormwater monitoring program. As part of the industrial stormwater program, the Discharger submitted a Storm Water Pollution Prevention Plan (SWPP), dated July 26, 2006. This Order requires the Discharger to obtain coverage under the general industrial stormwater permit program within 90 days of adoption of this permit. All future stormwater

monitoring and reporting will be coordinated through the general industrial stormwater program.

7. Compliance Schedules

a. Compliance Schedules for Final Effluent Limitations for Copper and Lead

- i. On or before May 18, 2010, the Discharger shall comply with the final effluent limitations for copper and lead. As this compliance schedule is greater than one year, the Discharger shall submit annual progress reports in accordance with the Monitoring and Reporting Program (Attachment E, Section X.D.1.)
 - ii. **Corrective Action Plan/Implementation Schedule.** The Discharger shall submit to the Regional Water Board a corrective action plan and implementation schedule to assure compliance with the final effluent limitations for copper and lead by May 18, 2010.
 - iii. **Pollution Prevention Plan.** The Discharger shall prepare and implement a pollution prevention plan for copper and lead, in accordance with CWC section 13263.3(d)(3). The minimum requirements for the pollution prevention plan are outlined in the Fact Sheet, Attachment F, VII.B.3.b. A work plan and time schedule for preparation of the pollution prevention plan shall be completed and submitted to the Regional Water Board **within 6 months of the effective date of this Order** for approval by the Executive Officer. The Pollution Prevention Plan shall be completed and submitted to the Regional Water Board **within one and one half (1 1/2) years following work plan approval by the Executive Officer**, and progress reports shall be submitted in accordance with the Monitoring and Reporting Program (Attachment E, Section X.D.1.).
- b. **Compliance Schedule for Salinity Evaluation and Minimization Plan.** The Discharger shall prepare a salinity evaluation and minimization plan to address sources of salinity from the Facility. The plan shall be completed and submitted to the Regional Water Board **within 2 years of the effective date of this Order** for the approval by the Executive Officer.

Table 10. Salinity Evaluation and Minimization Plan

| Task | Compliance Date |
|---------------------------------------|---|
| 1 - Submit Workplan and Time Schedule | Within 6 months of the effective date of Order |
| 2 - Begin Study | Within 3 months of Regional Board approval of Workplan and Time Schedule |
| 3 - Complete Study | As established by Task 1 |
| 4 - Submit Summary Report | 60 days following completion of Task 3 (no later than 2 years after the effective date of this Order) |

VII. COMPLIANCE DETERMINATION

The monitoring frequencies required by the monitoring and reporting program contained in this Order consider the feasibility, expense, and need for information. It is recognized that the required monitoring frequencies for the pollutants listed above will not provide enough data for a direct determination of whether or not a chronic water quality criterion or objective (generally 4-day averages) is being attained. Basin Plan maximum concentrations and CTR acute (generally 1-hour averages) concentrations can be directly compared against grab samples of the effluent and receiving water. Nonetheless, chronic water quality criteria and objectives are applicable, must be met, and are implemented by this Order. Compliance with the accelerated monitoring and TRE/TIE provisions of Provision VI.C.2.a shall constitute compliance with effluent limitation IV.A.1.e for chronic whole effluent toxicity.

ATTACHMENT A – DEFINITIONS

Arithmetic Mean (μ), also called the average, is the sum of measured values divided by the number of samples. For ambient water concentrations, the arithmetic mean is calculated as follows:

$$\text{Arithmetic mean} = \mu = \Sigma x / n \quad \text{where: } \Sigma x \text{ is the sum of the measured ambient water concentrations, and } n \text{ is the number of samples.}$$

Average Daily Discharge Flow Effluent Limitations. The Average Daily Discharge Flow represents the daily average flow when groundwater is at or near normal and runoff is not occurring. Compliance with the Average Daily Discharge Flow effluent limitations will be measured at times when groundwater is at or near normal and runoff is not occurring.

Average Monthly Effluent Limitation (AMEL): the highest allowable average of daily discharges over a calendar month, calculated as the sum of all daily discharges measured during a calendar month divided by the number of daily discharges measured during that month.

Average Weekly Effluent Limitation (AWEL): the highest allowable average of daily discharges over a calendar week (Sunday through Saturday), calculated as the sum of all daily discharges measured during a calendar week divided by the number of daily discharges measured during that week.

Best Practicable Treatment or Control (BPTC): BPTC is a requirement of State Water Resources Control Board Resolution 68-16 – “Statement of Policy with Respect to Maintaining High Quality of Waters in California” (referred to as the “Antidegradation Policy”). BPTC is the treatment or control of a discharge necessary to assure that, *“(a) a pollution or nuisance will not occur and (b) the highest water quality consistent with maximum benefit to the people of the State will be maintained.”* Pollution is defined in CWC Section 13050(I). In general, an exceedance of a water quality objective in the Basin Plan constitutes “pollution”.

Bioaccumulative pollutants are those substances taken up by an organism from its surrounding medium through gill membranes, epithelial tissue, or from food and subsequently concentrated and retained in the body of the organism.

Carcinogenic pollutants are substances that are known to cause cancer in living organisms.

Coefficient of Variation (CV) is a measure of the data variability and is calculated as the estimated standard deviation divided by the arithmetic mean of the observed values.

Daily Discharge: Daily Discharge is defined as either: (1) the total mass of the constituent discharged over the calendar day (12:00 am through 11:59 pm) or any 24-hour period that reasonably represents a calendar day for purposes of sampling (as specified in the permit), for a constituent with limitations expressed in units of mass or; (2) the unweighted arithmetic mean

measurement of the constituent over the day for a constituent with limitations expressed in other units of measurement (e.g., concentration).

The daily discharge may be determined by the analytical results of a composite sample taken over the course of one day (a calendar day or other 24-hour period defined as a day) or by the arithmetic mean of analytical results from one or more grab samples taken over the course of the day.

For composite sampling, if 1 day is defined as a 24-hour period other than a calendar day, the analytical result for the 24-hour period will be considered as the result for the calendar day in which the 24-hour period ends.

Detected, but Not Quantified (DNQ) are those sample results less than the RL, but greater than or equal to the laboratory's MDL.

Dilution Credit is the amount of dilution granted to a discharge in the calculation of a water quality-based effluent limitation, based on the allowance of a specified mixing zone. It is calculated from the dilution ratio or determined through conducting a mixing zone study or modeling of the discharge and receiving water.

Effluent Concentration Allowance (ECA) is a value derived from the water quality criterion/objective, dilution credit, and ambient background concentration that is used, in conjunction with the coefficient of variation for the effluent monitoring data, to calculate a long-term average (LTA) discharge concentration. The ECA has the same meaning as waste load allocation (WLA) as used in U.S. EPA guidance (Technical Support Document For Water Quality-based Toxics Control, March 1991, second printing, EPA/505/2-90-001).

Enclosed Bays means indentations along the coast that enclose an area of oceanic water within distinct headlands or harbor works. Enclosed bays include all bays where the narrowest distance between the headlands or outermost harbor works is less than 75 percent of the greatest dimension of the enclosed portion of the bay. Enclosed bays include, but are not limited to, Humboldt Bay, Bodega Harbor, Tomales Bay, Drake's Estero, San Francisco Bay, Morro Bay, Los Angeles-Long Beach Harbor, Upper and Lower Newport Bay, Mission Bay, and San Diego Bay. Enclosed bays do not include inland surface waters or ocean waters.

Estimated Chemical Concentration is the estimated chemical concentration that results from the confirmed detection of the substance by the analytical method below the ML value.

Estuaries means waters, including coastal lagoons, located at the mouths of streams that serve as areas of mixing for fresh and ocean waters. Coastal lagoons and mouths of streams that are temporarily separated from the ocean by sandbars shall be considered estuaries. Estuarine waters shall be considered to extend from a bay or the open ocean to a point upstream where there is no significant mixing of fresh water and seawater. Estuarine waters included, but are not limited to, the Sacramento-San Joaquin Delta, as defined in Water Code section 12220, Suisun Bay, Carquinez Strait downstream to the Carquinez Bridge, and appropriate areas of the Smith, Mad, Eel, Noyo, Russian, Klamath, San Diego, and Otay rivers. Estuaries do not include inland surface waters or ocean waters.

Inland Surface Waters are all surface waters of the State that do not include the ocean, enclosed bays, or estuaries.

Instantaneous Maximum Effluent Limitation: the highest allowable value for any single grab sample or aliquot (i.e., each grab sample or aliquot is independently compared to the instantaneous maximum limitation).

Instantaneous Minimum Effluent Limitation: the lowest allowable value for any single grab sample or aliquot (i.e., each grab sample or aliquot is independently compared to the instantaneous minimum limitation).

Maximum Daily Effluent Limitation (MDEL) means the highest allowable daily discharge of a pollutant, over a calendar day (or 24-hour period). For pollutants with limitations expressed in units of mass, the daily discharge is calculated as the total mass of the pollutant discharged over the day. For pollutants with limitations expressed in other units of measurement, the daily discharge is calculated as the arithmetic mean measurement of the pollutant over the day.

Median is the middle measurement in a set of data. The median of a set of data is found by first arranging the measurements in order of magnitude (either increasing or decreasing order). If the number of measurements (n) is odd, then the median = $X_{(n+1)/2}$. If n is even, then the median = $(X_{n/2} + X_{(n/2)+1})/2$ (i.e., the midpoint between the $n/2$ and $n/2+1$).

Method Detection Limit (MDL) is the minimum concentration of a substance that can be measured and reported with 99 percent confidence that the analyte concentration is greater than zero, as defined in title 40 of the Code of Federal Regulations, Part 136, Attachment B, revised as of July 3, 1999.

Minimum Level (ML) is the concentration at which the entire analytical system must give a recognizable signal and acceptable calibration point. The ML is the concentration in a sample that is equivalent to the concentration of the lowest calibration standard analyzed by a specific analytical procedure, assuming that all the method specified sample weights, volumes, and processing steps have been followed.

Mixing Zone is a limited volume of receiving water that is allocated for mixing with a wastewater discharge where water quality criteria can be exceeded without causing adverse effects to the overall water body.

Not Detected (ND) are those sample results less than the laboratory's MDL.

Ocean Waters are the territorial marine waters of the State as defined by California law to the extent these waters are outside of enclosed bays, estuaries, and coastal lagoons. Discharges to ocean waters are regulated in accordance with the State Water Board's California Ocean Plan.

Persistent pollutants are substances for which degradation or decomposition in the environment is nonexistent or very slow.

Pollutant Minimization Program (PMP) means waste minimization and pollution prevention actions that include, but are not limited to, product substitution, waste stream recycling, alternative waste management methods, and education of the public and businesses. The goal of the PMP shall be to reduce all potential sources of a priority pollutant(s) through pollutant minimization (control) strategies, including pollution prevention measures as appropriate, to maintain the effluent concentration at or below the water quality-based effluent limitation. Pollution prevention measures may be particularly appropriate for persistent bioaccumulative priority pollutants where there is evidence that beneficial uses are being impacted. The Regional Water Board may consider cost effectiveness when establishing the requirements of a PMP. The completion and implementation of a Pollution Prevention Plan, if required pursuant to Water Code section 13263.3(d), shall be considered to fulfill the PMP requirements.

Pollution Prevention means any action that causes a net reduction in the use or generation of a hazardous substance or other pollutant that is discharged into water and includes, but is not limited to, input change, operational improvement, production process change, and product reformulation (as defined in Water Code section 13263.3). Pollution prevention does not include actions that merely shift a pollutant in wastewater from one environmental medium to another environmental medium, unless clear environmental benefits of such an approach are identified to the satisfaction of the State or Regional Water Board.

Reporting Level (RL) is the ML (and its associated analytical method) chosen by the Discharger for reporting and compliance determination from the MLs included in this Order. The MLs included in this Order correspond to approved analytical methods for reporting a sample result that are selected by the Regional Water Board either from Appendix 4 of the SIP in accordance with section 2.4.2 of the SIP or established in accordance with section 2.4.3 of the SIP. The ML is based on the proper application of method-based analytical procedures for sample preparation and the absence of any matrix interferences. Other factors may be applied to the ML depending on the specific sample preparation steps employed. For example, the treatment typically applied in cases where there are matrix-effects is to dilute the sample or sample aliquot by a factor of ten. In such cases, this additional factor must be applied to the ML in the computation of the RL.

Satellite Collection System is the portion, if any, of a sanitary sewer system owned or operated by a different public agency than the agency that owns and operates the wastewater treatment facility that a sanitary sewer system is tributary to.

Source of Drinking Water is any water designated as municipal or domestic supply (MUN) in a Regional Water Board Basin Plan.

Standard Deviation (σ) is a measure of variability that is calculated as follows:

$$\sigma = \left(\frac{\sum[(x - \mu)^2]}{(n - 1)} \right)^{0.5}$$

where:

x is the observed value;

μ is the arithmetic mean of the observed values; and

n is the number of samples.

Toxicity Reduction Evaluation (TRE) is a study conducted in a step-wise process designed to identify the causative agents of effluent or ambient toxicity, isolate the sources of toxicity, evaluate the effectiveness of toxicity control options, and then confirm the reduction in toxicity. The first steps of the TRE consist of the collection of data relevant to the toxicity, including additional toxicity testing, and an evaluation of facility operations and maintenance practices, and best management practices. A Toxicity Identification Evaluation (TIE) may be required as part of the TRE, if appropriate. (A TIE is a set of procedures to identify the specific chemical(s) responsible for toxicity. These procedures are performed in three phases (characterization, identification, and confirmation) using aquatic organism toxicity tests.)

ATTACHMENT B-1 – MAP

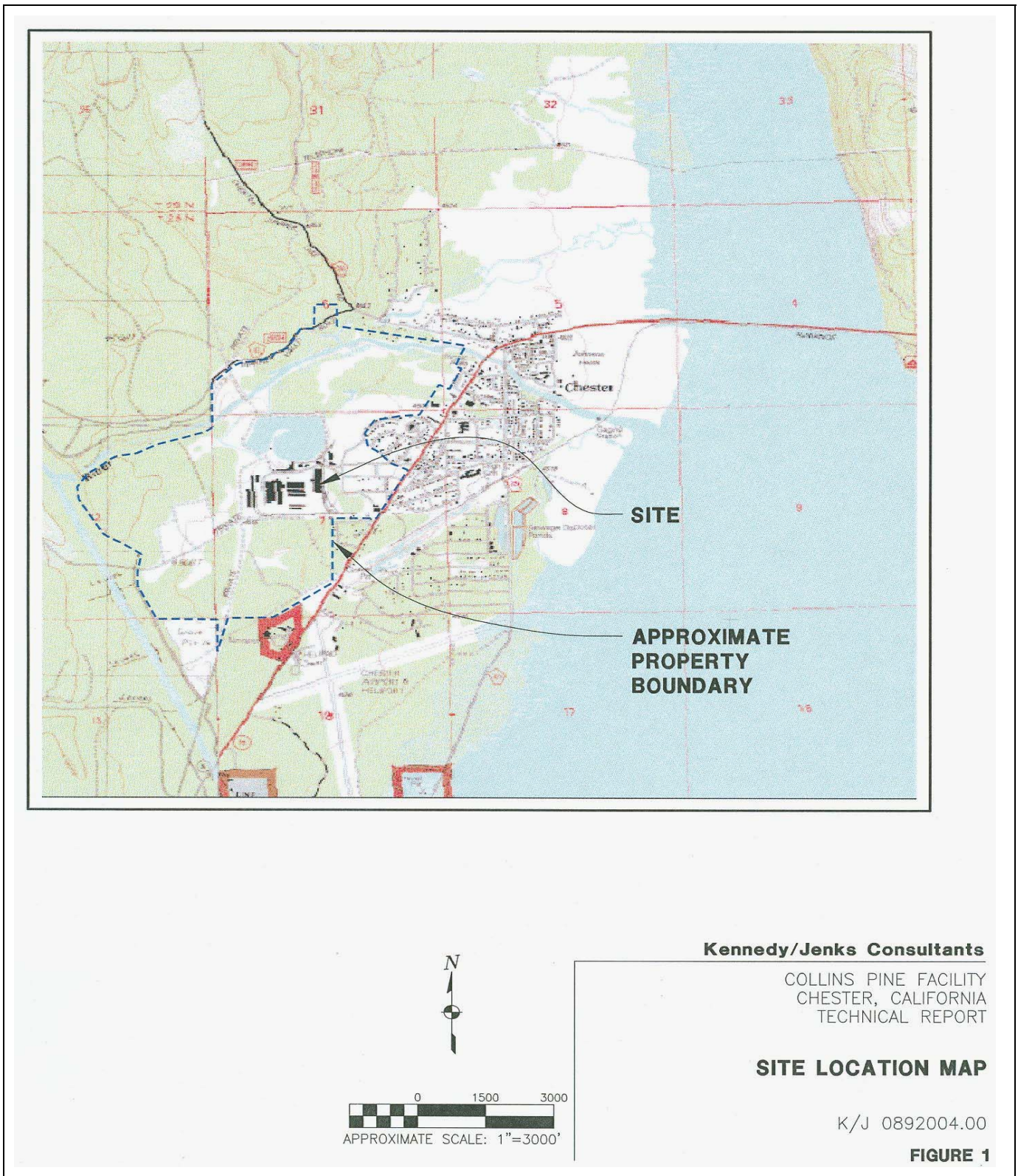

ATTACHMENT B-2 – AERIAL PHOTOGRAPH

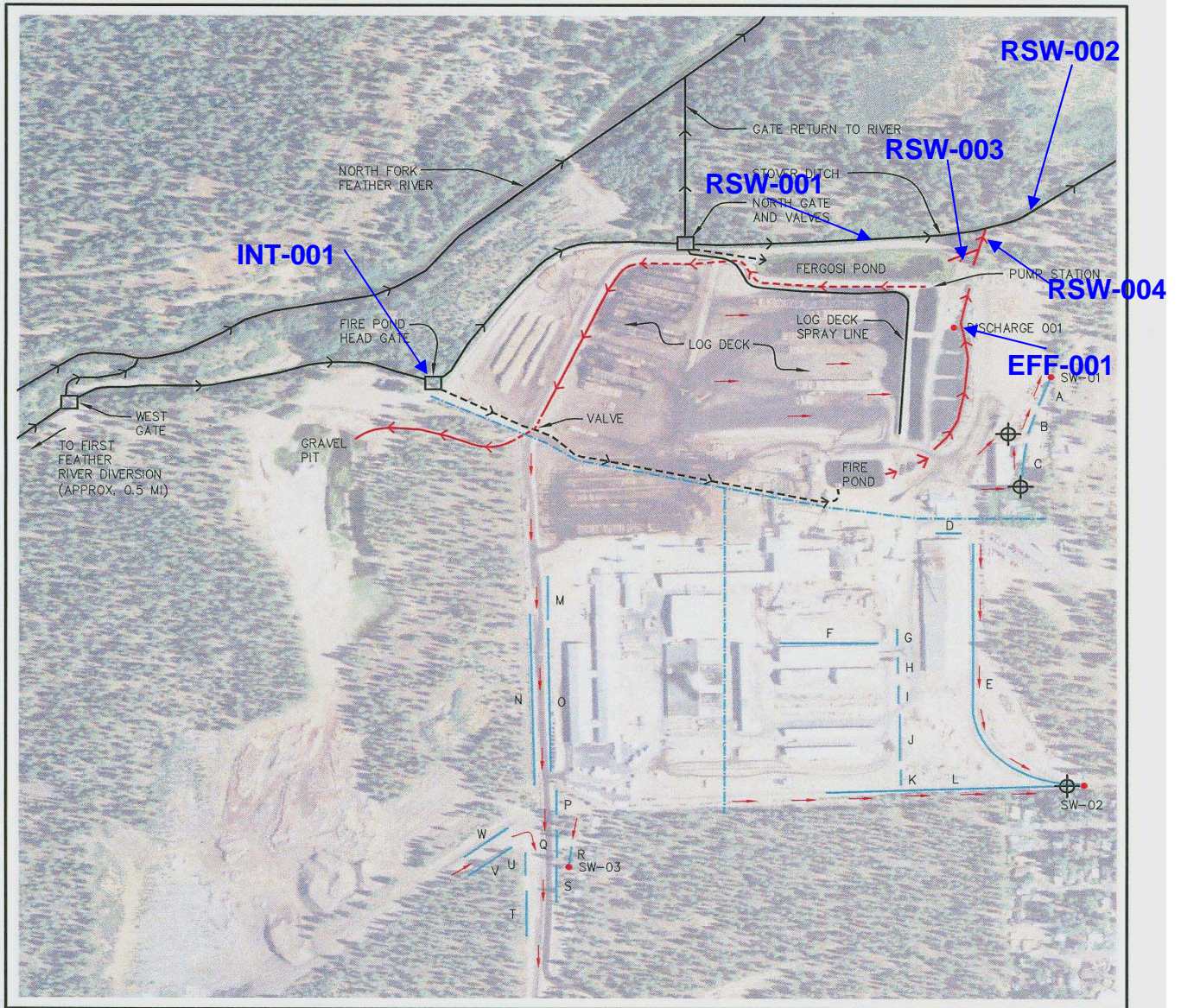

SOURCE: AERIAL PHOTO FROM LANDVOYAGE DATED 8/19/2005.

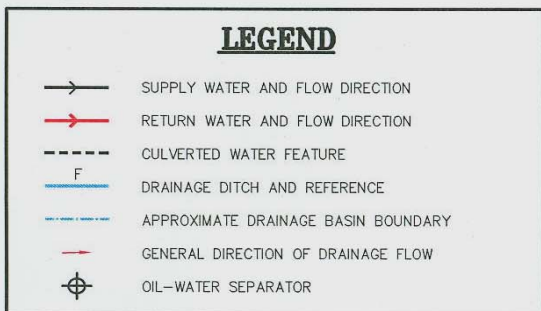

Kennedy/Jenks Consultants

COLLINS PINE FACILITY
CHESTER, CALIFORNIA
TECHNICAL REPORT

WATER FEATURES

K/J 0892004.00

FIGURE 3

ATTACHMENT C – FLOW SCHEMATIC

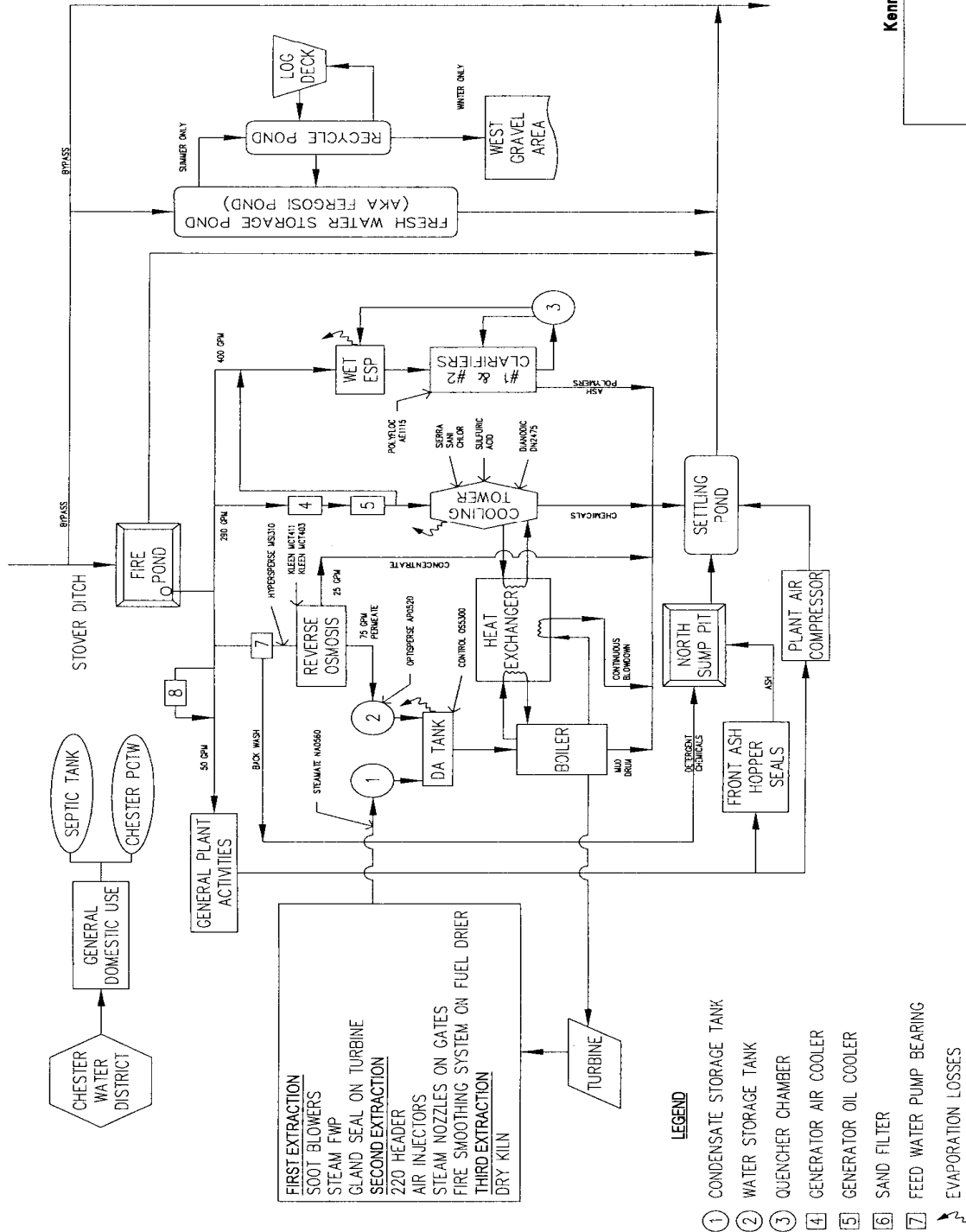

Kennedy/Jenks Consultants

COLLINS PINE FACILITY
CHESTER, CALIFORNIA
TECHNICAL REPORT

PROCESS WATER
FLOW DIAGRAM

K/J 0892004.00

FIGURE 4

ATTACHMENT D –STANDARD PROVISIONS

I. STANDARD PROVISIONS – PERMIT COMPLIANCE

A. Duty to Comply

1. The Discharger must comply with all of the conditions of this Order. Any noncompliance constitutes a violation of the Clean Water Act (CWA) and the California Water Code and is grounds for enforcement action, for permit termination, revocation and reissuance, or modification; or denial of a permit renewal application. (40 C.F.R. § 122.41(a).)
2. The Discharger shall comply with effluent standards or prohibitions established under Section 307(a) of the CWA for toxic pollutants and with standards for sewage sludge use or disposal established under Section 405(d) of the CWA within the time provided in the regulations that establish these standards or prohibitions, even if this Order has not yet been modified to incorporate the requirement. (40 C.F.R. § 122.41(a)(1).)

B. Need to Halt or Reduce Activity Not a Defense

It shall not be a defense for a Discharger in an enforcement action that it would have been necessary to halt or reduce the permitted activity in order to maintain compliance with the conditions of this Order. (40 C.F.R. § 122.41(c).)

C. Duty to Mitigate

The Discharger shall take all reasonable steps to minimize or prevent any discharge or sludge use or disposal in violation of this Order that has a reasonable likelihood of adversely affecting human health or the environment. (40 C.F.R. § 122.41(d).)

D. Proper Operation and Maintenance

The Discharger shall at all times properly operate and maintain all facilities and systems of treatment and control (and related appurtenances) which are installed or used by the Discharger to achieve compliance with the conditions of this Order. Proper operation and maintenance also includes adequate laboratory controls and appropriate quality assurance procedures. This provision requires the operation of backup or auxiliary facilities or similar systems that are installed by a Discharger only when necessary to achieve compliance with the conditions of this Order. (40 C.F.R. § 122.41(e).)

E. Property Rights

1. This Order does not convey any property rights of any sort or any exclusive privileges. (40 C.F.R. § 122.41(g).)

2. The issuance of this Order does not authorize any injury to persons or property or invasion of other private rights, or any infringement of state or local law or regulations. (40 C.F.R. § 122.5(c).)

F. Inspection and Entry

The Discharger shall allow the Regional Water Board, State Water Board, United States Environmental Protection Agency (USEPA), and/or their authorized representatives (including an authorized contractor acting as their representative), upon the presentation of credentials and other documents, as may be required by law, to (40 C.F.R. § 122.41(i); Wat. Code, § 13383):

1. Enter upon the Discharger's premises where a regulated facility or activity is located or conducted, or where records are kept under the conditions of this Order (40 C.F.R. § 122.41(i)(1));
2. Have access to and copy, at reasonable times, any records that must be kept under the conditions of this Order (40 C.F.R. § 122.41(i)(2));
3. Inspect and photograph, at reasonable times, any facilities, equipment (including monitoring and control equipment), practices, or operations regulated or required under this Order (40 C.F.R. § 122.41(i)(3)); and
4. Sample or monitor, at reasonable times, for the purposes of assuring Order compliance or as otherwise authorized by the CWA or the Water Code, any substances or parameters at any location. (40 C.F.R. § 122.41(i)(4).)

G. Bypass

1. Definitions
 - a. "Bypass" means the intentional diversion of waste streams from any portion of a treatment facility. (40 C.F.R. § 122.41(m)(1)(i).)
 - b. "Severe property damage" means substantial physical damage to property, damage to the treatment facilities, which causes them to become inoperable, or substantial and permanent loss of natural resources that can reasonably be expected to occur in the absence of a bypass. Severe property damage does not mean economic loss caused by delays in production. (40 C.F.R. § 122.41(m)(1)(ii).)
2. Bypass not exceeding limitations. The Discharger may allow any bypass to occur which does not cause exceedances of effluent limitations, but only if it is for essential maintenance to assure efficient operation. These bypasses are not subject to the provisions listed in Standard Provisions – Permit Compliance I.G.3, I.G.4, and I.G.5 below. (40 C.F.R. § 122.41(m)(2).)

3. Prohibition of bypass. Bypass is prohibited, and the Regional Water Board may take enforcement action against a Discharger for bypass, unless (40 C.F.R. § 122.41(m)(4)(i)):
 - a. Bypass was unavoidable to prevent loss of life, personal injury, or severe property damage (40 C.F.R. § 122.41(m)(4)(i)(A));
 - b. There were no feasible alternatives to the bypass, such as the use of auxiliary treatment facilities, retention of untreated wastes, or maintenance during normal periods of equipment downtime. This condition is not satisfied if adequate back-up equipment should have been installed in the exercise of reasonable engineering judgment to prevent a bypass that occurred during normal periods of equipment downtime or preventive maintenance (40 C.F.R. § 122.41(m)(4)(i)(B)); and
 - c. The Discharger submitted notice to the Regional Water Board as required under Standard Provisions – Permit Compliance I.G.5 below. (40 C.F.R. § 122.41(m)(4)(i)(C).)
4. The Regional Water Board may approve an anticipated bypass, after considering its adverse effects, if the Regional Water Board determines that it will meet the three conditions listed in Standard Provisions – Permit Compliance I.G.3 above. (40 C.F.R. § 122.41(m)(4)(ii).)
5. Notice
 - a. Anticipated bypass. If the Discharger knows in advance of the need for a bypass, it shall submit a notice, if possible at least 10 days before the date of the bypass. (40 C.F.R. § 122.41(m)(3)(i).)
 - b. Unanticipated bypass. The Discharger shall submit notice of an unanticipated bypass as required in Standard Provisions - Reporting V.E below (24-hour notice). (40 C.F.R. § 122.41(m)(3)(ii).)

H. Upset

Upset means an exceptional incident in which there is unintentional and temporary noncompliance with technology based permit effluent limitations because of factors beyond the reasonable control of the Discharger. An upset does not include noncompliance to the extent caused by operational error, improperly designed treatment facilities, inadequate treatment facilities, lack of preventive maintenance, or careless or improper operation. (40 C.F.R. § 122.41(n)(1).)

1. Effect of an upset. An upset constitutes an affirmative defense to an action brought for noncompliance with such technology based permit effluent limitations if the requirements of Standard Provisions – Permit Compliance I.H.2 below are met. No determination made during administrative review of claims that noncompliance was

caused by upset, and before an action for noncompliance, is final administrative action subject to judicial review. (40 C.F.R. § 122.41(n)(2).).

2. Conditions necessary for a demonstration of upset. A Discharger who wishes to establish the affirmative defense of upset shall demonstrate, through properly signed, contemporaneous operating logs or other relevant evidence that (40 C.F.R. § 122.41(n)(3)):
 - a. An upset occurred and that the Discharger can identify the cause(s) of the upset (40 C.F.R. § 122.41(n)(3)(i));
 - b. The permitted facility was, at the time, being properly operated (40 C.F.R. § 122.41(n)(3)(ii));
 - c. The Discharger submitted notice of the upset as required in Standard Provisions – Reporting V.E.2.b below (24-hour notice) (40 C.F.R. § 122.41(n)(3)(iii)); and
 - d. The Discharger complied with any remedial measures required under Standard Provisions – Permit Compliance I.C above. (40 C.F.R. § 122.41(n)(3)(iv).)
3. Burden of proof. In any enforcement proceeding, the Discharger seeking to establish the occurrence of an upset has the burden of proof. (40 C.F.R. § 122.41(n)(4).)

II. STANDARD PROVISIONS – PERMIT ACTION

A. General

This Order may be modified, revoked and reissued, or terminated for cause. The filing of a request by the Discharger for modification, revocation and reissuance, or termination, or a notification of planned changes or anticipated noncompliance does not stay any Order condition. (40 C.F.R. § 122.41(f).)

B. Duty to Reapply

If the Discharger wishes to continue an activity regulated by this Order after the expiration date of this Order, the Discharger must apply for and obtain a new permit. (40 C.F.R. § 122.41(b).)

C. Transfers

This Order is not transferable to any person except after notice to the Regional Water Board. The Regional Water Board may require modification or revocation and reissuance of the Order to change the name of the Discharger and incorporate such other requirements as may be necessary under the CWA and the Water Code. (40 C.F.R. § 122.41(l)(3); § 122.61.)

III. STANDARD PROVISIONS – MONITORING

- A. Samples and measurements taken for the purpose of monitoring shall be representative of the monitored activity. (40 C.F.R. § 122.41(j)(1).)
- B. Monitoring results must be conducted according to test procedures under Part 136 or, in the case of sludge use or disposal, approved under Part 136 unless otherwise specified in Part 503 unless other test procedures have been specified in this Order. (40 C.F.R. § 122.41(j)(4); § 122.44(i)(1)(iv).)

IV. STANDARD PROVISIONS – RECORDS

- A. Except for records of monitoring information required by this Order related to the Discharger's sewage sludge use and disposal activities, which shall be retained for a period of at least five years (or longer as required by Part 503), the Discharger shall retain records of all monitoring information, including all calibration and maintenance records and all original strip chart recordings for continuous monitoring instrumentation, copies of all reports required by this Order, and records of all data used to complete the application for this Order, for a period of at least three (3) years from the date of the sample, measurement, report or application. This period may be extended by request of the Regional Water Board Executive Officer at any time. (40 C.F.R. § 122.41(j)(2).)

B. Records of monitoring information shall include:

1. The date, exact place, and time of sampling or measurements (40 C.F.R. § 122.41(j)(3)(i));
2. The individual(s) who performed the sampling or measurements (40 C.F.R. § 122.41(j)(3)(ii));
3. The date(s) analyses were performed (40 C.F.R. § 122.41(j)(3)(iii));
4. The individual(s) who performed the analyses (40 C.F.R. § 122.41(j)(3)(iv));
5. The analytical techniques or methods used (40 C.F.R. § 122.41(j)(3)(v)); and
6. The results of such analyses. (40 C.F.R. § 122.41(j)(3)(vi).)

C. Claims of confidentiality for the following information will be denied (40 C.F.R. § 122.7(b)):

1. The name and address of any permit applicant or Discharger (40 C.F.R. § 122.7(b)(1)); and
2. Permit applications and attachments, permits and effluent data. (40 C.F.R. § 122.7(b)(2).)

V. STANDARD PROVISIONS – REPORTING

A. Duty to Provide Information

The Discharger shall furnish to the Regional Water Board, State Water Board, or USEPA within a reasonable time, any information which the Regional Water Board, State Water Board, or USEPA may request to determine whether cause exists for modifying, revoking and reissuing, or terminating this Order or to determine compliance with this Order. Upon request, the Discharger shall also furnish to the Regional Water Board, State Water Board, or USEPA copies of records required to be kept by this Order. (40 C.F.R. § 122.41(h); Wat. Code, § 13267.)

B. Signatory and Certification Requirements

1. All applications, reports, or information submitted to the Regional Water Board, State Water Board, and/or USEPA shall be signed and certified in accordance with Standard Provisions – Reporting V.B.2, V.B.3, V.B.4, and V.B.5 below. (40 C.F.R. § 122.41(k).)
2. All permit applications shall be signed by a responsible corporate officer. For the purpose of this section, a responsible corporate officer means: (i) A president, secretary, treasurer, or vice-president of the corporation in charge of a principal business function, or any other person who performs similar policy- or decision-making functions for the corporation, or (ii) the manager of one or more manufacturing, production, or operating facilities, provided, the manager is authorized to make management decisions which govern the operation of the regulated facility including having the explicit or implicit duty of making major capital investment recommendations, and initiating and directing other comprehensive measures to assure long term environmental compliance with environmental laws and regulations; the manager can ensure that the necessary systems are established or actions taken to gather complete and accurate information for permit application requirements; and where authority to sign documents has been assigned or delegated to the manager in accordance with corporate procedures. (40 C.F.R. § 122.22(a)(1).)
3. All reports required by this Order and other information requested by the Regional Water Board, State Water Board, or USEPA shall be signed by a person described in Standard Provisions – Reporting V.B.2 above, or by a duly authorized representative of that person. A person is a duly authorized representative only if:
 - a. The authorization is made in writing by a person described in Standard Provisions – Reporting V.B.2 above (40 C.F.R. § 122.22(b)(1));
 - b. The authorization specifies either an individual or a position having responsibility for the overall operation of the regulated facility or activity such as the position of plant manager, operator of a well or a well field, superintendent, position of

- equivalent responsibility, or an individual or position having overall responsibility for environmental matters for the company. (A duly authorized representative may thus be either a named individual or any individual occupying a named position.) (40 C.F.R. § 122.22(b)(2)); and
- c. The written authorization is submitted to the Regional Water Board and State Water Board. (40 C.F.R. § 122.22(b)(3).)
 4. If an authorization under Standard Provisions – Reporting V.B.3 above is no longer accurate because a different individual or position has responsibility for the overall operation of the facility, a new authorization satisfying the requirements of Standard Provisions – Reporting V.B.3 above must be submitted to the Regional Water Board and State Water Board prior to or together with any reports, information, or applications, to be signed by an authorized representative. (40 C.F.R. § 122.22(c).)
 5. Any person signing a document under Standard Provisions – Reporting V.B.2 or V.B.3 above shall make the following certification:

“I certify under penalty of law that this document and all attachments were prepared under my direction or supervision in accordance with a system designed to assure that qualified personnel properly gather and evaluate the information submitted. Based on my inquiry of the person or persons who manage the system or those persons directly responsible for gathering the information, the information submitted is, to the best of my knowledge and belief, true, accurate, and complete. I am aware that there are significant penalties for submitting false information, including the possibility of fine and imprisonment for knowing violations.” (40 C.F.R. § 122.22(d).)

C. Monitoring Reports

1. Monitoring results shall be reported at the intervals specified in the Monitoring and Reporting Program (Attachment E) in this Order. (40 C.F.R. § 122.22(l)(4).)
2. Monitoring results must be reported on a Discharge Monitoring Report (DMR) form or forms provided or specified by the Regional Water Board or State Water Board for reporting results of monitoring of sludge use or disposal practices. (40 C.F.R. § 122.41(l)(4)(i).)
3. If the Discharger monitors any pollutant more frequently than required by this Order using test procedures approved under Part 136 or, in the case of sludge use or disposal, approved under Part 136 unless otherwise specified in Part 503, or as specified in this Order, the results of this monitoring shall be included in the calculation and reporting of the data submitted in the DMR or sludge reporting form specified by the Regional Water Board. (40 C.F.R. § 122.41(l)(4)(ii).)
4. Calculations for all limitations, which require averaging of measurements, shall utilize an arithmetic mean unless otherwise specified in this Order. (40 C.F.R. § 122.41(l)(4)(iii).)

D. Compliance Schedules

Reports of compliance or noncompliance with, or any progress reports on, interim and final requirements contained in any compliance schedule of this Order, shall be submitted no later than 14 days following each schedule date. (40 C.F.R. § 122.41(l)(5).)

E. Twenty-Four Hour Reporting

1. The Discharger shall report any noncompliance that may endanger health or the environment. Any information shall be provided orally within 24 hours from the time the Discharger becomes aware of the circumstances. A written submission shall also be provided within five (5) days of the time the Discharger becomes aware of the circumstances. The written submission shall contain a description of the noncompliance and its cause; the period of noncompliance, including exact dates and times, and if the noncompliance has not been corrected, the anticipated time it is expected to continue; and steps taken or planned to reduce, eliminate, and prevent reoccurrence of the noncompliance. (40 C.F.R. § 122.41(l)(6)(i).)
2. The following shall be included as information that must be reported within 24 hours under this paragraph (40 C.F.R. § 122.41(l)(6)(ii)):
 - a. Any unanticipated bypass that exceeds any effluent limitation in this Order. (40 C.F.R. § 122.41(l)(6)(ii)(A).)
 - b. Any upset that exceeds any effluent limitation in this Order. (40 C.F.R. § 122.41(l)(6)(ii)(B).)
3. The Regional Water Board may waive the above-required written report under this provision on a case-by-case basis if an oral report has been received within 24 hours. (40 C.F.R. § 122.41(l)(6)(iii).)

F. Planned Changes

The Discharger shall give notice to the Regional Water Board as soon as possible of any planned physical alterations or additions to the permitted facility. Notice is required under this provision only when (40 C.F.R. § 122.41(l)(1)):

1. The alteration or addition to a permitted facility may meet one of the criteria for determining whether a facility is a new source in section 122.29(b) (40 C.F.R. § 122.41(l)(1)(i)); or
2. The alteration or addition could significantly change the nature or increase the quantity of pollutants discharged. This notification applies to pollutants that are subject neither to effluent limitations in this Order nor to notification requirements

under section 122.42(a)(1) (see Additional Provisions—Notification Levels VII.A.1). (40 C.F.R. § 122.41(l)(1)(ii).)

3. The alteration or addition results in a significant change in the Discharger's sludge use or disposal practices, and such alteration, addition, or change may justify the application of permit conditions that are different from or absent in the existing permit, including notification of additional use or disposal sites not reported during the permit application process or not reported pursuant to an approved land application plan. (40 C.F.R. § 122.41(l)(1)(iii).)

G. Anticipated Noncompliance

The Discharger shall give advance notice to the Regional Water Board or State Water Board of any planned changes in the permitted facility or activity that may result in noncompliance with General Order requirements. (40 C.F.R. § 122.41(l)(2).)

H. Other Noncompliance

The Discharger shall report all instances of noncompliance not reported under Standard Provisions – Reporting V.C, V.D, and V.E above at the time monitoring reports are submitted. The reports shall contain the information listed in Standard Provision – Reporting V.E above. (40 C.F.R. § 122.41(l)(7).)

I. Other Information

When the Discharger becomes aware that it failed to submit any relevant facts in a permit application, or submitted incorrect information in a permit application or in any report to the Regional Water Board, State Water Board, or USEPA, the Discharger shall promptly submit such facts or information. (40 C.F.R. § 122.41(l)(8).)

VI. STANDARD PROVISIONS – ENFORCEMENT

- A. The Regional Water Board is authorized to enforce the terms of this permit under several provisions of the Water Code, including, but not limited to, sections 13385, 13386, and 13387.

VII. ADDITIONAL PROVISIONS – NOTIFICATION LEVELS

A. Non-Municipal Facilities

Existing manufacturing, commercial, mining, and silvicultural Dischargers shall notify the Regional Water Board as soon as they know or have reason to believe (40 C.F.R. § 122.42(a)):

1. That any activity has occurred or will occur that would result in the discharge, on a routine or frequent basis, of any toxic pollutant that is not limited in this Order, if that discharge will exceed the highest of the following "notification levels" (40 C.F.R. § 122.42(a)(1)):
 - a. 100 micrograms per liter ($\mu\text{g/L}$) (40 C.F.R. § 122.42(a)(1)(i));
 - b. 200 $\mu\text{g/L}$ for acrolein and acrylonitrile; 500 $\mu\text{g/L}$ for 2,4-dinitrophenol and 2-methyl-4,6-dinitrophenol; and 1 milligram per liter (mg/L) for antimony (40 C.F.R. § 122.42(a)(1)(ii));
 - c. Five (5) times the maximum concentration value reported for that pollutant in the Report of Waste Discharge (40 C.F.R. § 122.42(a)(1)(iii)); or
 - d. The level established by the Regional Water Board in accordance with section 122.44(f). (40 C.F.R. § 122.42(a)(1)(iv).)
2. That any activity has occurred or will occur that would result in the discharge, on a non-routine or infrequent basis, of any toxic pollutant that is not limited in this Order, if that discharge will exceed the highest of the following "notification levels" (40 C.F.R. § 122.42(a)(2)):
 - a. 500 micrograms per liter ($\mu\text{g/L}$) (40 C.F.R. § 122.42(a)(2)(i));
 - b. 1 milligram per liter (mg/L) for antimony (40 C.F.R. § 122.42(a)(2)(ii));
 - c. Ten (10) times the maximum concentration value reported for that pollutant in the Report of Waste Discharge (40 C.F.R. § 122.42(a)(2)(iii)); or
 - d. The level established by the Regional Water Board in accordance with section 122.44(f). (40 C.F.R. § 122.42(a)(2)(iv).)

ATTACHMENT E – MONITORING AND REPORTING PROGRAM

Table of Contents

| | |
|---|------|
| Attachment E – Monitoring and Reporting Program (MRP)..... | E-1 |
| I. General Monitoring Provisions..... | E-1 |
| II. Monitoring Locations | E-2 |
| III. Influent Monitoring Requirements..... | E-2 |
| A. Monitoring Location INT-001..... | E-2 |
| IV. Effluent Monitoring Requirements | E-3 |
| A. Monitoring Location EFF-001..... | E-3 |
| B. Monitoring Location - Not Applicable | E-4 |
| V. Whole Effluent Toxicity Testing Requirements | E-5 |
| VI. ASH SETTLING POND MONITORING REQUIREMENTS | E-8 |
| A. Monitoring Location – Ash Settling Pond | E-8 |
| VII. Reclamation Monitoring Requirements – Not Applicable..... | E-8 |
| VIII. Receiving Water Monitoring Requirements – Surface Water and Groundwater | E-8 |
| A. Monitoring Location RSW-001, RSW-002, RSW-003 | E-8 |
| IX. Other Monitoring Requirements..... | E-9 |
| A. Precipitation Monitoring | E-9 |
| X. Reporting Requirements..... | E-11 |
| A. General Monitoring and Reporting Requirements..... | E-11 |
| B. Self Monitoring Reports (SMRs) | E-12 |
| C. Discharge Monitoring Reports (DMRs) – Not Applicable | E-14 |
| D. Other Reports | E-14 |

List of Tables

| | |
|--|------|
| Table E-1. Monitoring Station Locations | E-2 |
| Table E-2. Influent Monitoring..... | E-3 |
| Table E-3. Effluent Monitoring | E-4 |
| Table E-4. Chronic Toxicity Testing Dilution Series | E-6 |
| Table E-5. Ash Settling Pond Monitoring Requirements..... | E-8 |
| Table E-6. Receiving Water Monitoring Requirements | E-8 |
| Table E-7. Receiving Water Monitoring Requirements | E-9 |
| Table E-8. Ash Monitoring | E-10 |
| Table E-9. Monitoring Periods and Reporting Schedule | E-14 |
| Table E-10. Reporting Requirements for Special Provisions Progress Reports | E-15 |

ATTACHMENT E – MONITORING AND REPORTING PROGRAM (MRP)

The Code of Federal Regulations section 122.48 requires that all NPDES permits specify monitoring and reporting requirements. Water Code Sections 13267 and 13383 also authorize the Regional Water Quality Control Board (Regional Water Board) to require technical and monitoring reports. This MRP establishes monitoring and reporting requirements, which implement the federal and state regulations.

I. GENERAL MONITORING PROVISIONS

- A. Samples and measurements taken as required herein shall be representative of the volume and nature of the monitored discharge. All samples shall be taken at the monitoring locations specified below and, unless otherwise specified, before the monitored flow joins or is diluted by any other waste stream, body of water, or substance. Monitoring locations shall not be changed without notification to and the approval of this Regional Water Board.
- B. Chemical, bacteriological, and bioassay analyses shall be conducted at a laboratory certified for such analyses by the State Department of Health Services. In the event a certified laboratory is not available to the Discharger, analyses performed by a noncertified laboratory will be accepted provided a Quality Assurance-Quality Control Program is instituted by the laboratory. A manual containing the steps followed in this program must be kept in the laboratory and shall be available for inspection by Regional Water Board staff. The Quality Assurance-Quality Control Program must conform to USEPA guidelines or to procedures approved by the Regional Water Board.
- C. All analyses shall be performed in a laboratory certified to perform such analyses by the California Department of Health Services. Laboratories that perform sample analyses shall be identified in all monitoring reports.
- D. Appropriate flow measurement devices and methods consistent with accepted scientific practices shall be selected and used to ensure the accuracy and reliability of measurements of the volume of monitored discharges. All monitoring instruments and devices used by the Discharger to fulfill the prescribed monitoring program shall be properly maintained and calibrated as necessary to ensure their continued accuracy. All flow measurement devices shall be calibrated at least once per year to ensure continued accuracy of the devices.
- E. Monitoring results, including noncompliance, shall be reported at intervals and in a manner specified in this Monitoring and Reporting Program.

II. MONITORING LOCATIONS

The Discharger shall establish the following monitoring locations to demonstrate compliance with the effluent limitations, discharge specifications, and other requirements in this Order:

Table E-1. Monitoring Station Locations

| Discharge Point Name | Monitoring Location Name | Monitoring Location Description (include Latitude and Longitude when available) |
|----------------------|--------------------------|--|
| | INT-001 | Intake water at Fire Pond head gate |
| 001 | EFF-001 | Discharge point from ash settling pond, 40', 18', 24" N, 121°, 14', 31" W |
| -- | RSW-001 | surface water monitoring location – Stover Ditch, 50ft upstream from where the eastern drainage ditch discharges to Stover Ditch |
| -- | RSW-002 | surface water monitoring location – Stover Ditch, 50ft downstream from where the eastern drainage ditch discharges to Stover Ditch |
| -- | RSW-003 | surface water monitoring location – discharger of Fresh Water Pond (Fergosi Pond) |
| | RSW-004 | surface water monitoring location – downstream of Fresh Water Pond (Fergosi Pond), and upstream of Stover Ditch |

III. INFLUENT MONITORING REQUIREMENTS

A. Monitoring Location INT-001

1. The Discharger shall monitor intake water at the Fire Pond head gate at INT-001 as follows:

Table E-2. Influent Monitoring

| Parameter | Units | Sample Type | Minimum Sampling Frequency | Required Analytical Test Method |
|----------------------------------|----------|-------------|----------------------------|---------------------------------|
| Priority Pollutants ¹ | ug/L | Grab | Twice ² | ³ |
| Electrical Conductivity @ 25°C | umhos/cm | Grab | 1/year | ³ |
| pH | pH units | Grab | 1/year | ³ |
| Hardness | mg/L | Grab | 1/year | ³ |

¹ For priority pollutant constituents with effluent limitations, detection limits shall be below the effluent limitations. If the lowest minimum level (ML) published in Appendix 4 of the Policy for Implementation of Toxics Standards for Inland Surface Waters, Enclosed Bays, and Estuaries of California (State Implementation Plan or SIP) is not below the effluent limitation, the detection limit shall be the lowest ML. For priority pollutant constituents without effluent limitations, the detection limits shall be equal to or less than the lowest ML published in Appendix 4 of the SIP

² First sampling event should be during the 1st 2-years of the permit, and one set during the 2nd 2-years of the permit.

³ Pollutants shall be analyzed using the analytical methods described in 40 CFR Part 136. For priority pollutant constituents with effluent limitations, detection limits shall be below the effluent limitations. If the lowest minimum level (ML) published in Appendix 4 of the Policy for Implementation of Toxics Standards for Inland Surface Waters, Enclosed Bays, and Estuaries of California (State Implementation Plan or SIP) is not below the effluent limitation, the detection limit shall be the lowest ML. For priority pollutant constituents without effluent limitations, the detection limits shall be equal to or less than the lowest ML published in Appendix 4 of the SIP. Where no methods are specified for a given pollutant, by methods approved by this Regional Water Board or the State Water Board

IV. EFFLUENT MONITORING REQUIREMENTS

A. Monitoring Location EFF-001

1. The Discharger shall monitor the discharge from the ash settling ponds at EFF-001 as follows, during periods of discharge. If more than one analytical test method is listed for a given parameter, the Discharger must select from the listed methods and corresponding Minimum Level:

Table E-3. Effluent Monitoring

| Parameter | Units | Sample Type | Minimum Sampling Frequency | Required Analytical Test Method and (Minimum Level, units), respectively ¹ |
|----------------------------------|-------------------------------|-------------|----------------------------|---|
| Flow | mgd | Grab | 1/day | ⁶ |
| pH | pH units | Meter | 1/day | ⁶ |
| Settleable Solids | mL/L | Grab | 1/day | ⁶ |
| Electrical Conductivity @ 25°C | µmhos/cm | Meter | 1/day | ⁶ |
| Turbidity | NTU | Grab | 1/week | ⁶ |
| Total Suspended Solids | mg/L | Grab | 1/week | ⁶ |
| Temperature | °F | Meter | 1/week | ⁶ |
| Chemical Oxygen Demand | mg/L | Grab | 1/month | ⁶ |
| Chlorine Residual | mg/L | Grab | 1/month | ⁶ |
| Tannins and Lignins | mg/L | Grab | 1/month | ⁶ |
| Copper | ug/L | Grab | 1/month | ⁶ |
| Lead | ug/L | Grab | 1/month | ⁶ |
| Acute Toxicity ² | percent survival | Grab | 1/quarter | ⁶ |
| Chronic Toxicity | percent survival ⁷ | Grab | 1/year | ⁶ |
| General Minerals ³ | ug/L | Grab | 1/year | ⁶ |
| Oil and Grease | mg/L | Grab | 2/year | ⁶ |
| Priority Pollutants ⁴ | ug/L | Grab | Bi-annually ⁵ | ⁶ |

1 Samples shall be collected during continuous discharge. If the discharge is intermittent rather than continuous, then the first day each intermittent discharge shall be monitored, but at a frequency of not more than twice the frequency noted.

2 96-hr bioassay test using rainbow trout as the test species – static renewal

3 Standard minerals shall include the following: boron, calcium, iron, magnesium, potassium, sodium, chloride, manganese, phosphorus, total alkalinity (including alkalinity series), and hardness, and include verification that the analysis is complete (i.e., cation/anion balance)

4 For priority pollutant constituents with effluent limitations, detection limits shall be below the effluent limitations. If the lowest minimum level (ML) published in Appendix 4 of the Policy for Implementation of Toxics Standards for Inland Surface Waters, Enclosed Bays, and Estuaries of California (State Implementation Plan or SIP) is not below the effluent limitation, the detection limit shall be the lowest ML. For priority pollutant constituents without effluent limitations, the detection limits shall be equal to or less than the lowest ML published in Appendix 4 of the SIP.

5 First sampling event should be during the 1st 2-years of the permit, and one set during the 2nd 2-years of the permit

6 Pollutants shall be analyzed using the analytical methods described in 40 CFR Part 136. For priority pollutant constituents with effluent limitations, detection limits shall be below the effluent limitations. If the lowest minimum level (ML) published in Appendix 4 of the Policy for Implementation of Toxics Standards for Inland Surface Waters, Enclosed Bays, and Estuaries of California (State Implementation Plan or SIP) is not below the effluent limitation, the detection limit shall be the lowest ML. For priority pollutant constituents without effluent limitations, the detection limits shall be equal to or less than the lowest ML published in Appendix 4 of the SIP. Where no methods are specified for a given pollutant, by methods approved by this Regional Water Board or the State Water Board

7 Results include percent survival in all three species (water flea, fathead minnow, green alga)

B. Monitoring Location - Not Applicable

V. WHOLE EFFLUENT TOXICITY TESTING REQUIREMENTS

- A. **Acute Toxicity Testing.** The Discharger shall conduct acute toxicity testing to determine whether the effluent is contributing acute toxicity to the receiving water. The Discharger shall meet the following acute toxicity testing requirements:
1. Monitoring Frequency – the Discharger shall perform **quarterly** acute toxicity testing.
 2. Sample Types – For static non-renewal and static renewal testing, the samples shall be grab samples and shall be representative of the volume and quality of the discharge. The effluent samples shall be taken at the effluent monitoring location EFF-001.
 3. Test Species – Test species shall be rainbow trout (***Oncorhynchus mykiss***).
 4. Methods – The acute toxicity testing samples shall be analyzed using EPA-821-R-02-012, Fifth Edition. Temperature, total residual chlorine, and pH shall be recorded at the time of sample collection. No pH adjustment may be made unless approved by the Executive Officer.
 5. Test Failure – If an acute toxicity test does not meet all test acceptability criteria, as specified in the test method, the Discharger must re-sample and re-test as soon as possible, not to exceed 7 days following notification of test failure.
- B. **Chronic Toxicity Testing.** The Discharger shall conduct three species chronic toxicity testing to determine whether the effluent is contributing chronic toxicity to the receiving water. The Discharger shall meet the following chronic toxicity testing requirements:
1. Monitoring Frequency – the Discharger shall perform annual three species chronic toxicity testing.
 2. Sample Types – Effluent samples shall be grab samples and shall be representative of the volume and quality of the discharge. The effluent samples shall be taken at the effluent monitoring location specified in the Monitoring and Reporting Program. The receiving water control shall be a grab sample obtained from the **RSW-001 (Upstream sampling location out of influence of the discharge)** sampling location, as identified in the Monitoring and Reporting Program.
 3. Sample Volumes – Adequate sample volumes shall be collected to provide renewal water to complete the test in the event that the discharge is intermittent.
 4. Test Species – Chronic toxicity testing measures sublethal (e.g. reduced growth, reproduction) and/or lethal effects to test organisms exposed to an effluent compared to that of the control organisms. The Discharger shall conduct chronic toxicity tests with:

- The cladoceran, water flea, *Ceriodaphnia dubia* (survival and reproduction test);
 - The fathead minnow, *Pimephales promelas* (larval survival and growth test); and
 - The green alga, *Selenastrum capricornutum* (growth test).
5. **Methods** – The presence of chronic toxicity shall be estimated as specified in *Short-term Methods for Estimating the Chronic Toxicity of Effluents and Receiving Waters to Freshwater Organisms, Fourth Edition, EPA/821-R-02-013, October 2002.*
 6. **Reference Toxicant** – As required by the SIP, all chronic toxicity tests shall be conducted with concurrent testing with a reference toxicant and shall be reported with the chronic toxicity test results.
 7. **Dilutions** – The chronic toxicity testing shall be performed using 100% effluent and two controls. If toxicity is found in any effluent test, the Discharger must immediately retest using the dilution series identified in Table E-4, below. The receiving water control shall be used as the diluent (unless the receiving water is toxic).
 8. **Test Failure** –The Discharger must re-sample and re-test as soon as possible, but no later than fourteen (14) days after receiving notification of a test failure. A test failure is defined as follows:
 - a. The reference toxicant test or the effluent test does not meet all test acceptability criteria as specified in the *Short-term Methods for Estimating the Chronic Toxicity of Effluents and Receiving Waters to Freshwater Organisms, Fourth Edition, EPA/821-R-02-013, October 2002 (Method Manual),* and its subsequent amendments or revisions; or
 - b. The percent minimum significant difference (PMSD) measured for the test exceeds the upper PMSD bound variability criterion in Table 6 on page 52 of the Method Manual. (A retest is only required in this case if the test results do not exceed the monitoring trigger specified in **Special Provisions VI.C.2.a.iii.**)

Table E-4. Chronic Toxicity Testing Dilution Series

| Sample | Dilutions (%) | | | | | Controls | |
|--------------------|---------------|----|----|----|------|-----------------|------------------|
| | 100 | 75 | 50 | 25 | 12.5 | Receiving Water | Laboratory Water |
| % Effluent | 100 | 75 | 50 | 25 | 12.5 | 0 | 0 |
| % Receiving Water | 0 | 25 | 50 | 75 | 87.5 | 100 | 0 |
| % Laboratory Water | 0 | 0 | 0 | 0 | 0 | 0 | 100 |

C. WET Testing Notification Requirements. The Discharger shall notify the Regional Water Board within 24-hrs after the receipt of test results exceeding the monitoring

trigger during regular or accelerated monitoring, or an exceedance of the acute toxicity effluent limitation.

D. WET Testing Reporting Requirements. All toxicity test reports shall include the contracting laboratory's complete report provided to the Discharger and shall be in accordance with the appropriate "Report Preparation and Test Review" sections of the method manuals. At a minimum, whole effluent toxicity monitoring shall be reported as follows:

1. **Chronic WET Reporting.** Regular chronic toxicity monitoring results shall be reported to the Regional Water Board within 30 days following completion of the test, and shall contain, at minimum:
 - a. The results expressed in TUC, measured as 100/NOEC, and also measured as 100/LC₅₀, 100/EC₂₅, 100/IC₂₅, and 100/IC₅₀, as appropriate.
 - b. The statistical methods used to calculate endpoints;
 - c. The statistical output page, which includes the calculation of the percent minimum significant difference (PMSD);
 - d. The dates of sample collection and initiation of each toxicity test; and
 - e. The results compared to the numeric toxicity monitoring trigger.

Additionally, the monthly discharger self-monitoring reports shall contain an updated chronology of chronic toxicity test results expressed in TUC, and organized by test species, type of test (survival, growth or reproduction), and monitoring frequency, i.e., either quarterly, monthly, accelerated, or TRE.

2. **Acute WET Reporting.** Acute toxicity test results shall be submitted with the monthly discharger self-monitoring reports and reported as percent survival.
3. **TRE Reporting.** Reports for Toxicity Reduction Evaluations shall be submitted in accordance with the schedule contained in the Discharger's approved TRE Work Plan.
4. **Quality Assurance (QA).** The Discharger must provide the following information for QA purposes (If applicable):
 - a. Results of the applicable reference toxicant data with the statistical output page giving the species, NOEC, LOEC, type of toxicant, dilution water used, concentrations used, PMSD, and dates tested.
 - b. The reference toxicant control charts for each endpoint, which include summaries of reference toxicant tests performed by the contracting laboratory.
 - c. Any information on deviations or problems encountered and how they were dealt with.

VI. ASH SETTLING POND MONITORING REQUIREMENTS

A. Monitoring Location – Ash Settling Pond

1. The Discharger shall monitor the Ash Settling Pond as follows:

Table E-5. Ash Settling Pond Monitoring Requirements

| Parameter | Units | Sample Type | Minimum Sampling Frequency | Required Analytical Test Method |
|------------------|----------------|-------------|----------------------------|---------------------------------|
| Dissolved Oxygen | mg/L | Grab | 1/week | |
| pH | Standard Units | Grab | 1/week | |
| Freeboard | ft | Grab | 1/week | |

VII. RECLAMATION MONITORING REQUIREMENTS – NOT APPLICABLE

VIII. RECEIVING WATER MONITORING REQUIREMENTS – SURFACE WATER AND GROUNDWATER

A. Monitoring Location RSW-001, RSW-002, RSW-003, RSW-004

The Discharger shall monitor Stover Ditch at RSW-001, RSW-002, RSW-003 and RSW-004 as follows:

Table E-6. Receiving Water Monitoring Requirements

| Parameter | Units | Sample Type | Minimum Sampling Frequency | Required Analytical Test Method |
|---|----------------|-------------|----------------------------|---------------------------------|
| Visual Observations ^{1, 2} | NA | Visual | 1/week | |
| Temperature ^{2, 3} | °F (°C) | Grab | 1/week | |
| pH ² | Standard Units | Grab | 1/week | |
| Electrical Conductivity @ 25°C ² | µmhos/cm | Grab | 1/week | |
| Dissolved Oxygen ² | mg/L | Grab | 1/week | |
| Turbidity ² | NTU | Grab | 1/week | |

- 1 In conducting the receiving water sampling, a log shall be kept of the receiving water conditions in Stover Ditch bounded by Stations RSW-001, RSW-002, and RSW-003. Attention shall be given to the presence or absence of: a) bark or sawdust, b) floating or suspended matter, c) oil sheen or slick, d) discoloration, e) scum or foam, f) bottom deposits, g) aquatic life, and h) upstream flow in Stover Ditch.
- 2 RSW-001, RSW-002, RSW-003 only
- 3 RSW-004 only

IX. OTHER MONITORING REQUIREMENTS

A. Precipitation Monitoring

Precipitation information shall be submitted monthly, and shall contain the following:

Table E-7. Receiving Water Monitoring Requirements

| Parameter | Units | Sample Type | Minimum Sampling Frequency | Required Analytical Test Method |
|---------------|--------|-------------|----------------------------|---------------------------------|
| Precipitation | inches | Gauge | 1/day | |

B. Ash Monitoring

Sludge, wood waste and ash, removed from the liquid waste shall be monitored to assure that disposal of these material is disposed of in a manner approved by the Executive Office and consistent with consolidated Regulations for Treatment, Storage, Processing, or Disposal of Solid Waste, as set forth in Title 27, California Code of Regulations, division 2, Subdivision 1, Section 20005. Specifically, the ash shall be monitored according to Table E-8:

Table E-8. Ash Monitoring

| Parameter | Units | Sample Type | Minimum Sampling Frequency | Required Analytical Test Method |
|--|----------------|-------------|----------------------------|---------------------------------|
| Volume of fly ash generated | cubic yards | Grab | 1/month | |
| Volume of bottom ash generated | cubic yards | Grab | 1/month | |
| Volume of ash stored at the facility | cubic yards | Grab | 1/month | |
| Volume of ash removed from facility | cubic yards | Grab | 1/month | |
| Disposal location of ash | Location | Grab | 1/month | |
| Land Disposal of Ash: Area of land where ash was applied | Acres | Grab | 1/month | |
| Land Disposal of Ash: Volume of ash applied | cubic yards | Grab | 1/month | |
| pH | Standard units | Grab | 1/month | |
| Copper | ug/L | Grab | 1/month | |
| Lead | ug/L | Grab | 1/month | |
| Moisture content | % moisture | Grab | 1/year | |
| General Minerals ¹ | mg/kg or mg/L | Grab | 1/year | |
| Priority Pollutant ² Metals | mg/kg or ug/L | Grab | 1/year | |
| Metals ³ | mg/kg or ug/L | Grab | 1/year | |

¹ Standard minerals shall include the following: boron, calcium, iron, magnesium, potassium, sodium, chloride, manganese, phosphorus, total alkalinity (including alkalinity series), and hardness, and include verification that the analysis is complete (i.e., cation/anion balance)

² Includes the following: antimony, arsenic, beryllium, cadmium, chromium III, chromium VI, cyanide, mercury, nickel, selenium, silver, thallium, and zinc

³ Includes the following: aluminum, barium, boron, cobalt, iron, manganese, molybdenum, and vanadium

C. Aboveground Petroleum Storage Tank Monitoring

The Discharger shall visually inspect the aboveground petroleum storage tanks, as required by the facility's Spill Prevention Control and Countermeasure Plan. A report of the inspection shall be submitted with the monthly monitoring report. In the event of a petroleum release, a report shall be submitted describing the corrective

action that was taken to remediate and dispose of the contaminated area. The results shall be submitted with the monthly monitoring report.

X. REPORTING REQUIREMENTS

A. General Monitoring and Reporting Requirements

1. The Discharger shall comply with all Standard Provisions (Attachment D) related to monitoring, reporting, and recordkeeping.
1. Upon written request of the Regional Water Board, the Discharger shall submit a summary monitoring report. The report shall contain both tabular and graphical summaries of the monitoring data obtained during the previous year(s).
2. **Compliance Time Schedules.** For compliance time schedules included in the Order, the Discharger shall submit to the Regional Water Board, on or before each compliance due date, the specified document or a written report detailing compliance or noncompliance with the specific date and task. If noncompliance is reported, the Discharger shall state the reasons for noncompliance and include an estimate of the date when the Discharger will be in compliance. The Discharger shall notify the Regional Water Board by letter when it returns to compliance with the compliance time schedule.
3. The Discharger shall report to the Regional Water Board any toxic chemical release data it reports to the State Emergency Response Commission within 15 days of reporting the data to the Commission pursuant to section 313 of the "Emergency Planning and Community Right to Know Act of 1986.
4. **Reporting Protocols.** The Discharger shall report with each sample result the applicable Reporting Level (RL) and the current Method Detection Limit (MDL), as determined by the procedure in Part 136.

The Discharger shall report the results of analytical determinations for the presence of chemical constituents in a sample using the following reporting protocols:

- a. Sample results greater than or equal to the RL shall be reported as measured by the laboratory (i.e., the measured chemical concentration in the sample).
- b. Sample results less than the RL, but greater than or equal to the laboratory's MDL, shall be reported as "Detected, but Not Quantified," or DNQ. The estimated chemical concentration of the sample shall also be reported.

For the purposes of data collection, the laboratory shall write the estimated chemical concentration next to DNQ as well as the words "Estimated Concentration" (may be shortened to "Est. Conc."). The laboratory may, if such information is available, include numerical estimates of the data quality for the reported result. Numerical estimates of data quality may be percent accuracy (\pm a percentage of the reported value), numerical ranges (low to high), or any other means considered appropriate by the laboratory.

- c. Sample results less than the laboratory's MDL shall be reported as "Not Detected," or ND.
 - d. Dischargers are to instruct laboratories to establish calibration standards so that the ML value (or its equivalent if there is differential treatment of samples relative to calibration standards) is the lowest calibration standard. At no time is the Discharger to use analytical data derived from *extrapolation* beyond the lowest point of the calibration curve.
5. **Multiple Sample Data.** When determining compliance with an AMEL , AWEL, or MDEL for priority pollutants and more than one sample result is available, the Discharger shall compute the arithmetic mean unless the data set contains one or more reported determinations of "Detected, but Not Quantified" (DNQ) or "Not Detected" (ND). In those cases, the Discharger shall compute the median in place of the arithmetic mean in accordance with the following procedure:
- a. The data set shall be ranked from low to high, ranking the reported ND determinations lowest, DNQ determinations next, followed by quantified values (if any). The order of the individual ND or DNQ determinations is unimportant.
 - b. The median value of the data set shall be determined. If the data set has an odd number of data points, then the median is the middle value. If the data set has an even number of data points, then the median is the average of the two values around the middle unless one or both of the points are ND or DNQ, in which case the median value shall be the lower of the two data points where DNQ is lower than a value and ND is lower than DNQ.

B. Self Monitoring Reports (SMRs)

1. At any time during the term of this permit, the State or Regional Water Board may notify the Discharger to electronically submit Self-Monitoring Reports (SMRs) using the State Water Board's California Integrated Water Quality System (CIWQS) Program Web site (<http://www.waterboards.ca.gov/ciwqs/index.html>). Until such notification is given, the Discharger shall submit hard copy SMRs. The CIWQS Web site will provide additional directions for SMR submittal in the event there will be service interruption for electronic submittal.
2. Monitoring results shall be submitted to the Regional Water Board by the **first day** of the second month following sample collection. Quarterly and annual monitoring results shall be submitted by the **first day of the second month following each calendar quarter, semi-annual period, and year**, respectively.
3. In reporting the monitoring data, the Discharger shall arrange the data in tabular form so that the date, the constituents, and the concentrations are readily discernible. The data shall be summarized in such a manner to illustrate clearly whether the discharge complies with waste discharge requirements. The highest daily maximum for the month, monthly and weekly averages, and medians shall be determined and recorded as needed to demonstrate compliance.

4. With the exception of flow, all constituents monitored on a continuous basis (metered), shall be reported as daily maximums, daily minimums, and daily averages; flow shall be reported as the total volume discharged per day for each day of discharge.
5. If the Discharger monitors any pollutant at the locations designated herein more frequently than is required by this Order, the results of such monitoring shall be included in the calculation and reporting of the values required in the discharge monitoring report form. Such increased frequency shall be indicated on the discharge monitoring report form.
6. A letter transmitting the self-monitoring reports shall accompany each report. Such a letter shall include a discussion of requirement violations found during the reporting period, and actions taken or planned for correcting noted violations, such as operation or facility modifications. If the Discharger has previously submitted a report describing corrective actions and/or a time schedule for implementing the corrective actions, reference to the previous correspondence will be satisfactory. The transmittal letter shall contain the penalty of perjury statement by the Discharger, or the Discharger's authorized agent, as described in the Standard Provisions.
7. SMRs must be submitted to the Regional Water Board, signed and certified as required by the Standard Provisions (Attachment D), to the address listed below:

Regional Water Quality Control Board
Central Valley Region – Redding Office
415 Knollcrest Drive, Suite #100
Redding, CA 96002-0129

8. Monitoring periods and reporting for all required monitoring shall be completed according to the following schedule:

Table E-9. Monitoring Periods and Reporting Schedule

| Sampling Frequency | Monitoring Period Begins On... | Monitoring Period | SMR Due Date |
|--------------------|--|---|---|
| Continuous | Permit effective date | All | Submit with monthly SMR |
| Hourly | Permit effective date | Hourly | Submit with monthly SMR |
| Daily | Permit effective date | (Midnight through 11:59 PM) or any 24-hour period that reasonably represents a calendar day for purposes of sampling. | Submit with monthly SMR |
| Weekly | Sunday following permit effective date or on permit effective date if on a Sunday | Sunday through Saturday | Submit with monthly SMR |
| Monthly | First day of calendar month following permit effective date or on permit effective date if that date is first day of the month | 1 st day of calendar month through last day of calendar month | First day of the second month following month of sampling |
| Quarterly | Closest of January 1, April 1, July 1, or October 1 following (or on) permit effective date | January 1 through March 31 April 1 through June 30 July 1 through September 30 October 1 through December 31 | May 1 August 1 November 1 February 1 |
| Semiannually | Closest of January 1 or July 1 following (or on) permit effective date | January 1 through June 30 July 1 through December 31 | August 1 February 1 |
| Annually | January 1 following (or on) permit effective date | January 1 through December 31 | February 1 |

C. Discharge Monitoring Reports (DMRs) – Not Applicable

D. Other Reports

- 1. Progress Reports.** As specified in the compliance time schedules required in Special Provisions VI, progress reports shall be submitted in accordance with the following reporting requirements. At minimum, the progress reports shall include a discussion of the status of final compliance, whether the Discharger is on schedule to meet the final compliance date, and the remaining tasks to meet the final compliance date.

Table E-10. Reporting Requirements for Special Provisions Progress Reports

| Special Provision | Reporting Requirements |
|---|--|
| Pollution Prevention Plan for Copper and Lead | 31 January , update after approval of work plan |
| Salinity Evaluation and Minimization Plan | 31 January , update after approval of work plan |
| Constituent Study for copper and lead | 31 January , annually, after approval of work plan |
| Compliance Schedule update for Final Effluent Limitations for copper and lead | 31 January , annually, after approval of work plan until final compliance |

2. Within **60 days** of permit adoption, the Discharger shall submit a report outlining minimum levels, method detection limits, and analytical methods for approval, with a goal to achieve detection levels below applicable water quality criteria. At a minimum, the Discharger shall comply with the monitoring requirements for CTR constituents as outlined in Section 2.3 and 2.4 of the *Policy for Implementation of Toxics Standards for Inland Surface Waters, Enclosed Bays, and Estuaries of California*, adopted 2 March 2000 by the State Water Resources Control Board. All peaks identified by analytical methods shall be reported.

3. **Annual Operations Report.** By **30 January** of each year, the Discharger shall submit a written report to the Executive Officer containing the following:
 - a. The names, certificate grades, and general responsibilities of all persons employed at the Facility.
 - b. The names and telephone numbers of persons to contact regarding the plant for emergency and routine situations.
 - c. A statement certifying when the flow meter(s) and other monitoring instruments and devices were last calibrated, including identification of who performed the calibration.
 - d. A statement certifying whether the current operation and maintenance manual, and contingency plan, reflect the wastewater treatment plant as currently constructed and operated, and the dates when these documents were last revised and last reviewed for adequacy.

- e. The Discharger may also be requested to submit an annual report to the Regional Water Board with both tabular and graphical summaries of the monitoring data obtained during the previous year. Any such request shall be made in writing. The report shall discuss the compliance record. If violations have occurred, the report shall also discuss the corrective actions taken and planned to bring the discharge into full compliance with the waste discharge requirements.

ATTACHMENT F – FACT SHEET

Table of Contents

| | |
|---|------|
| Attachment F – Fact Sheet | F-3 |
| I. Permit Information | F-3 |
| II. Facility Description | F-4 |
| A. Description of Wastewater and Biosolids Treatment or Controls | F-4 |
| B. Discharge Points and Receiving Waters..... | F-5 |
| C. Summary of Existing Requirements and Self-Monitoring Report (SMR) Data | F-5 |
| D. Compliance Summary..... | F-6 |
| E. Planned Changes | F-7 |
| III. Applicable Plans, Policies, and Regulations | F-7 |
| A. Legal Authority | F-7 |
| B. California Environmental Quality Act (CEQA) | F-7 |
| C. State and Federal Regulations, Policies, and Plans | F-7 |
| D. Impaired Water Bodies on CWA 303(d) List | F-9 |
| E. Other Plans, Policies and Regulations..... | F-9 |
| IV. Rationale For Effluent Limitations and Discharge Specifications..... | F-10 |
| A. Discharge Prohibitions | F-11 |
| B. Technology-Based Effluent Limitations..... | F-11 |
| 1. Scope and Authority | F-11 |
| 2. Applicable Technology-Based Effluent Limitations | F-12 |
| C. Water Quality-Based Effluent Limitations (WQBELs)..... | F-13 |
| 1. Scope and Authority | F-13 |
| 2. Applicable Beneficial Uses and Water Quality Criteria and Objectives..... | F-13 |
| 3. Determining the Need for WQBELs..... | F-16 |
| 4. WQBEL Calculations | F-24 |
| 5. Whole Effluent Toxicity (WET)..... | F-26 |
| D. Final Effluent Limitations | F-28 |
| 1. Mass-based Effluent Limitations..... | F-28 |
| 2. Averaging Periods for Effluent Limitations | F-28 |
| 3. Satisfaction of Anti-Backsliding Requirements | F-28 |
| 4. Satisfaction of Antidegradation Policy | F-29 |
| E. Interim Effluent Limitations..... | F-29 |
| F. Land Discharge Specifications..... | F-30 |
| G. Reclamation Specifications..... | F-30 |
| V. Rationale for Receiving Water Limitations | F-31 |
| A. Surface Water | F-31 |
| B. Groundwater | F-34 |
| VI. Rationale for Monitoring and Reporting Requirements | F-34 |
| A. Influent Monitoring | F-35 |
| B. Effluent Monitoring | F-35 |
| C. Whole Effluent Toxicity Testing Requirements | F-35 |
| D. Receiving Water Monitoring..... | F-35 |
| 1. Surface Water..... | F-35 |
| 2. Groundwater..... | F-36 |

- E. Other Monitoring Requirements F-36
- VII. Rationale for Provisions F-36
 - A. Standard Provisions F-36
 - B. Special Provisions..... F-37
 - 1. Reopener Provisions F-37
 - 2. Special Studies and Additional Monitoring Requirements F-37
 - 3. Best Management Practices and Pollution Prevention F-41
 - 4. Construction, Operation, and Maintenance Specifications F-42
 - 5. Special Provisions for Municipal Facilities (POTWs Only)..... F-42
 - 6. Other Special Provisions F-42
 - 7. Compliance Schedules F-43
- VIII. Public Participation F-43
 - A. Notification of Interested Parties F-44
 - B. Written Comments F-44
 - C. Public Hearing F-44
 - D. Waste Discharge Requirements Petitions..... F-45
 - E. Information and Copying..... F-45
 - F. Register of Interested Persons F-45
 - G. Additional Information F-45

List of Tables

- Table F-1. Facility Information F-3
- Table F-2. Historic Effluent Limitations and Monitoring Data F-5
- Table F-3. Summary of Technology-based Effluent Limitations F-13
- Table F-4. Summary of Reasonable Potential Analysis..... F-18
- Table F-5. Summary of Applicable Priority Pollutant Criterion/Objectives F-19
- Table F-6. Salinity Water Quality Criteria/Objectives F-22
- Table F-7 WQBEL Calculations for Copper F-25
- Table F-8 WQBEL Calculations for Lead F-25
- Table F-9 WQBEL Calculation Summary Table F-26
- Table F-10. Summary of Water Quality-based Effluent Limitations F-26
- Table F-11. Summary of Final Effluent Limitations F-29
- Table F-12. Interim Effluent Limitation Calculation Summary F-30

ATTACHMENT F – FACT SHEET

As described in section II of this Order, this Fact Sheet includes the legal requirements and technical rationale that serve as the basis for the requirements of this Order.

This Order has been prepared under a standardized format to accommodate a broad range of discharge requirements for Dischargers in California. Only those sections or subsections of this Order that are specifically identified as “not applicable” have been determined not to apply to this Discharger. Sections or subsections of this Order not specifically identified as “not applicable” are fully applicable to this Discharger.

I. PERMIT INFORMATION

The following table summarizes administrative information related to the facility.

Table F-1. Facility Information

| | |
|---|---|
| WDID | 5A322000001 |
| Discharger | Collins Pine Company |
| Name of Facility | Collins Pine Company – Chester Sawmill |
| Facility Address | 500 Main Street |
| | Chester, CA 96020 |
| | Plumas County |
| Facility Contact, Title and Phone | Chris Verderber, Manager, 530-258-2111 |
| Authorized Person to Sign and Submit Reports | Walter Nystrom, Power Plant Co-Gen Supervisor, 530-258-2111 |
| Mailing Address | SAME |
| Billing Address | P.O. Box 796, Chester, CA 96020 |
| Type of Facility | Industrial (Sawmills and planing mills, general - SIC 2421, electrical services – SIC 4911) |
| Major or Minor Facility | Minor |
| Threat to Water Quality | 2 |
| Complexity | A |
| Pretreatment Program | N |
| Reclamation Requirements | NA |
| Facility Permitted Flow | 0.36 (in million gallons per day) |
| Facility Design Flow | 0.36 Facility Design Flow (in million gallons per day) |
| Watershed | North Fork Feather River |
| Receiving Water | Stover Ditch |
| Receiving Water Type | Inland surface water |

- A. Collins Pine Company (hereinafter Discharger) is the owner and operator of the Collins Pine Company Chester Sawmill (hereinafter Facility), an industrial sawmill/planing mill

and electrical cogeneration plant. Collins Pine Company owns the property at 500 Main Street, Chester on which the Facility is located.

For the purposes of this Order, references to the “discharger” or “permittee” in applicable federal and state laws, regulations, plans, or policy are held to be equivalent to references to the Discharger herein.

- B.** The Facility discharges wastewater to Stover Ditch, a water of the United States, and is currently regulated by Order R5-2004-0012 which was adopted on January 30, 2004 and expires on January 1, 2009.
- C.** The Discharger filed a report of waste discharge and submitted an application for renewal of its Waste Discharge Requirements (WDRs) and National Pollutant Discharge Elimination System (NPDES) permit on June 26, 2008. Supplemental information was requested on June 25, 2008 and received on August 8, 2008. A site visit was conducted on June 23, 2008, to observe operations and collect additional data to develop permit limitations and conditions.

II. FACILITY DESCRIPTION

Collins Pine Company – Chester Sawmill operates a sawmill and wood-burning cogeneration facility in Chester, in Sections 6, 7 and 8, T28N, R7E, MDB&M and Section 12, T28N, R6E MDB&M as shown on Attachment B. The sawmill produces approximately 120 million board feet of lumber per year. The cogeneration plant currently produces a gross 12-megawatts (MW) of electric power, and a net 6-MW, which are sold on the market.

A. Description of Wastewater and Biosolids Treatment or Controls

Process water is drawn from Stover Ditch (diversion from North Fork Feather River), and supplies the fire pond and freshwater pond (Fergosi Pond). Approximately 290 gallons per minute (gpm) is used for cooling tower and approximately 400 gpm is used for air pollution control equipment.

The cooling tower loses approximately 270 gpm to evaporation and blows down about 20 gpm to a sump pit, from which it flows to a settling pond before joining the discharge at Stover Ditch (D-001).

Approximately 120 gpm of raw water is processed through a sand filter and then through a reverse osmosis unit for use in the boiler. Occasional backwashing of the sand filters is discharged to the settling ponds, prior to D-001. Approximately 30 gpm of reverse osmosis water is used by the boiler, which removes solids using a mud drum. The solids are combined with the ash waste for land application. The boiler generates 5 gpm of blowdown water which flows to the settling ponds and D-001.

Approximately 50 gpm of raw water is used for general plant activities, including ash hopper seals and equipment cooling. Return water from these process flows is sent to the settling pond and D-001.

The air pollution control equipment discharge treatment consists of a quench chamber and wet electrostatic precipitator (ESP). After the ESP, the process water is split between two clarifiers that use polymer to settle out the solids. Fly ash is separated by the clarifiers and is combined with the boiler ash for offsite disposal. The treated water from the ESP flows into the first of four settling ponds, prior to the discharge at D-001. Carbon dioxide is bubbled into the last settling pond, prior to discharge, to stabilize pH of the process water.

Solids from the treatment system are land applied in accordance with Collins Pine’s ash management plan. The ash management plan covers the boiler bottom ash, boiler fly ash, clarifier sludge, and settling pond sludge.

B. Discharge Points and Receiving Waters

1. The Facility is located in Sections 6, 7 and 8, T28N, R7E, and Section 12, T28N, R6E, MDB&M, as shown in Attachment B (Figure B-1), a part of this Order.
2. Treated municipal wastewater is discharged at Discharge Point 001 to Stover Ditch, a water of the United States [*and a tributary to Lake Almanor*] at a point Latitude 40°, 18’, 30” N and longitude 121°, 14’, 31” W.

C. Summary of Existing Requirements and Self-Monitoring Report (SMR) Data

Effluent limitations/Discharge Specifications contained in the existing Order for discharges from 001 (Monitoring Location D-001) and representative monitoring data from the term of the previous Order are as follows:

Table F-2. Historic Effluent Limitations and Monitoring Data

| Parameter | Units | Effluent Limitation | | | Highest Average Monthly Discharge | Highest Daily Discharge |
|------------------------|----------|---------------------|----------------|---------------|-----------------------------------|-------------------------|
| | | Average Monthly | Average Weekly | Maximum Daily | | |
| Suspended Solids | mg/L | | | 40 | 20.48 | 66 |
| Settleable Solids | mL/L | 0.1 | | 0.2 | 0.2 | 0.2 |
| Specific Conductance | umhos/cm | | | 900 | 395.51 | 570 |
| Chemical Oxygen Demand | mg/L | | | 40 | 19.04 | 56 |
| pH | pH units | | | 6.0 – 9.0 | 8.62 | 9.36 |

D. Compliance Summary

The following is a summary of violations noted during the monthly monitoring and reporting report review since the last permit cycle:

| <u>Occurrence Date</u> | <u>Violation Description</u> |
|------------------------|--|
| 01/20/04 | Acute toxicity failure |
| 03/16/04 | Acute toxicity failure |
| 07/24/04 | Fish mortality in Stover Ditch |
| 07/25/04 | Acute toxicity failure |
| 07/30/04 | Acute toxicity failure |
| 08/06/04 | Acute toxicity failure |
| 09/14/04 | Acute toxicity failure |
| 10/01/04 | Report missing receiving water data |
| 11/01/04 | Report missing receiving water data |
| 11/02/04 | Acute toxicity failure |
| 12/01/04 | Report missing receiving water data |
| 12/01/04 | Late report |
| 2/01/05 | Violation of receiving water limitation – pH |
| 3/01/05 | Insufficient monitoring of stormwater runoff |
| 3/01/05 | Violation of receiving water limitation – pH |
| 3/08/05 | Violation of receiving water limitation – pH |
| 3/23/05 | Violation of receiving water limitation – pH |
| 3/30/05 | Violation of receiving water limitation – pH |
| 5/8/05 | Violation of receiving water limitation – pH |
| 5/23/05 | Violation of receiving water limitation – pH |
| 6/21/05 | Acute toxicity failure |
| 07/23/05 | Violation of receiving water limitation – pH |
| 01/01/06 | Effluent suspended solids violation |
| 04/30/07 | Late report |
| 05/29/07 | Effluent pH exceedance |
| 07/18/07 | Effluent pH exceedance |
| 09/04/07 | Effluent pH exceedance |
| 10/31/07 | Receiving water turbidity exceedance |
| 12/31/07 | Receiving water temperature exceedance |
| 01/31/08 | Receiving water turbidity exceedance |

1. The Discharger received a Notice of Violation from the Regional Board dated April 4, 2007 for effluent and receiving violations, for the period of January 2006 through January 2007. This Notice of Violation resulted in a Mandatory Penalty Complaint on May 9, 2007 for violations of waste discharge requirements for a total of \$12,000.
2. The Discharger received a Notice of Violation from the Regional Board dated July 25, 2005 for violation of effluent limitation (acute toxicity testing).
3. The Discharger received a Notice of Violation from the Regional Board dated October 5, 2004 for effluent and receiving violations, for the period of January

2004 through September 2004. This Notice of Violation resulted in a Mandatory Penalty Complaint on February 15, 2005 for violations of waste discharge requirements for a total of \$12,000.

4. The Discharger received a Notice of Violation from the Regional Board for acute toxicity test failure on May 20, 2004.
5. The Discharger received a Notice of Violation from the Regional Board for acute toxicity test failure on March 22, 2004.

E. Planned Changes

The Facility did not propose any alternative discharge options for the process wastewater disposal. As part of the best practicable treatment and control systems (in 2006), the Discharger considered going to a closed loop cooling and air pollution control system. However, because of salt buildup associated with the closed loop process, the alternative was not developed.

III. APPLICABLE PLANS, POLICIES, AND REGULATIONS

The requirements contained in this Order are based on the applicable plans, policies, and regulations identified in section II of the Limitations and Discharge Requirements (Findings). This section provides supplemental information, where appropriate, for the plans, policies, and regulations relevant to the discharge.

A. Legal Authority

See Limitations and Discharge Requirements - [Findings](#), Section II.C.

B. California Environmental Quality Act (CEQA)

See Limitations and Discharge Requirements - Findings, Section II.E.

C. State and Federal Regulations, Policies, and Plans

1. **Water Quality Control Plans.** The Regional Water Board adopted a *Water Quality Control Plan, Fourth Edition (Revised August 2006)*, for the Sacramento and San Joaquin River Basins (Basin Plan) that designates beneficial uses, establishes water quality objectives, and contains implementation programs and policies to achieve those objectives for all waters addressed through the plan. In addition, State Water Board Resolution No. 88-63 requires that, with certain exceptions, the Regional Water Board assign the municipal and domestic supply use to water bodies that do not have beneficial uses listed in the Basin Plan. The beneficial uses of the Stover Ditch downstream of the discharge are hydropower generation, water contact recreation, warm freshwater aquatic habitat, cold freshwater aquatic habitat, warm spawning habitat and wildlife habitat. All groundwater in the Region is considered as suitable or potentially suitable, at a minimum, for municipal and domestic water supply, agricultural supply, industrial service supply and industrial process supply. The beneficial uses of the groundwater

The Basin Plan on page II-1.00 states: "*Protection and enhancement of existing and potential beneficial uses are primary goals of water quality planning...*" and with respect to disposal of wastewaters states that "...*disposal of wastewaters is [not] a*

prohibited use of waters of the State; it is merely a use which cannot be satisfied to the detriment of beneficial uses.”

The federal CWA section 101(a)(2), states: “*it is the national goal that wherever attainable, an interim goal of water quality which provides for the protection and propagation of fish, shellfish, and wildlife, and for recreation in and on the water be achieved by July 1, 1983.*” Federal Regulations, developed to implement the requirements of the CWA, create a rebuttable presumption that all waters be designated as fishable and swimmable. Federal Regulations, 40 CFR sections 131.2 and 131.10, require that all waters of the State regulated to protect the beneficial uses of public water supply, protection and propagation of fish, shell fish and wildlife, recreation in and on the water, agricultural, industrial and other purposes including navigation. Section 131.3(e), 40 CFR, defines existing beneficial uses as those uses actually attained after November 28, 1975, whether or not they are included in the water quality standards. Federal Regulation, 40 CFR section 131.10 requires that uses be obtained by implementing effluent limitations, requires that all downstream uses be protected and states that in no case shall a state adopt waste transport or waste assimilation as a beneficial use for any waters of the United States.

2. **Thermal Plan. Not Applicable**

3. **Bay-Delta Plan. Not Applicable**

4. **Antidegradation Policy.** Section 131.12 requires that the state water quality standards include an antidegradation policy consistent with the federal policy. The State Water Board established California’s antidegradation policy in State Water Board Resolution No. 68-16. Resolution No. 68-16 incorporates the federal antidegradation policy where the federal policy applies under federal law. Resolution No. 68-16 requires that existing water quality be maintained unless degradation is justified based on specific findings. The Regional Water Board’s Basin Plan implements, and incorporates by reference, both the State and federal antidegradation policies. As discussed in detail in the Fact Sheet (Attachment F, Section IV.D.4.) the discharge is consistent with the antidegradation provisions of 40 CFR section 131.12 and State Water Board Resolution 68-16.

5. **Anti-Backsliding Requirements.** Sections 402(o)(2) and 303(d)(4) of the CWA and federal regulations at title 40, Code of Federal Regulations section 122.44(l) prohibit backsliding in NPDES permits. These anti-backsliding provisions require that effluent limitations in a reissued permit must be as stringent as those in the previous permit, with some exceptions in which limitations may be relaxed. Compliance with the Anti-Backsliding requirements is discussed in Section IV.D.3.

6. **Emergency Planning and Community Right to Know Act.** Not Applicable. Facility is not a POTW, and does not discharge wastes, other than domestic wastes into a POTW collection system.

7. **Stormwater Requirements.** USEPA promulgated Federal Regulations for storm water on 16 November 1990 in 40 CFR Parts 122, 123, and 124. The NPDES Industrial Storm Water Program regulates storm water discharges from wastewater treatment facilities. Sawmill plants are applicable industries under the stormwater program and are obligated to comply with the Federal Regulations.

The existing permit regulates industrial storm water discharges from the Facility. Generally upon permit renewal, the Regional Water Board is requiring dischargers with individual permits that discharge industrial storm water to obtain coverage under the general industrial storm water permit. Therefore, the Discharger is required to obtain coverage under the general industrial storm water permit within **90 days** of adoption of this permit.

8. **Endangered Species Act.** This Order does not authorize any act that results in the taking of a threatened or endangered species or any act that is now prohibited, or becomes prohibited in the future, under either the California Endangered Species Act (Fish and Game Code sections 2050 to 2097) or the Federal Endangered Species Act (16 U.S.C.A. sections 1531 to 1544). This Order requires compliance with effluent limits, receiving water limits, and other requirements to protect the beneficial uses of waters of the state. The Discharger is responsible for meeting all requirements of the applicable Endangered Species Act.

D. Impaired Water Bodies on CWA 303(d) List

1. Under Section 303(d) of the 1972 Clean Water Act, states, territories and authorized tribes are required to develop lists of water quality limited segments. The waters on these lists do not meet water quality standards, even after point sources of pollution have installed the minimum required levels of pollution control technology. On July 25, 2003 USEPA gave final approval to California's 2002 Section 303(d) List of Water Quality Limited Segments. The Basin Plan references this list of Water Quality Limited Segments (WQLSs), which are defined as "...those sections of lakes, streams, rivers or other fresh water bodies where water quality does not meet (or is not expected to meet) water quality standards even after the application of appropriate limitations for point sources (40 CFR 130, et seq.)." The Basin Plan also states, "Additional treatment beyond minimum federal standards will be imposed on dischargers to [WQLSs]. Dischargers will be assigned or allocated a maximum allowable load of critical pollutants so that water quality objectives can be met in the segment." The receiving water has not been 303d-listed.
2. **Total Maximum Daily Loads.** No TMDL has been adopted for the receiving water.

E. Other Plans, Policies and Regulations

1. The State Water Board adopted the *Water Quality Control Policy for the Enclosed Bays and Estuaries of California*. The requirements within this Order are consistent with the Policy.

IV. RATIONALE FOR EFFLUENT LIMITATIONS AND DISCHARGE SPECIFICATIONS

Effluent limitations and toxic and pretreatment effluent standards established pursuant to Sections 301 (Effluent Limitations), 302 (Water Quality Related Effluent Limitations), 304 (Information and Guidelines), and 307 (Toxic and Pretreatment Effluent Standards) of the Clean Water Act (CWA) and amendments thereto are applicable to the discharge.

The Federal CWA mandates the implementation of effluent limitations that are as stringent as necessary to meet water quality standards established pursuant to state or federal law [33 U.S.C., § 1311(b)(1)(C); 40 CFR, § 122.44(d)(1)]. NPDES permits must incorporate discharge limits necessary to ensure that water quality standards are met. This requirement applies to narrative criteria as well as to criteria specifying maximum amounts of particular pollutants. Pursuant to Federal Regulations, 40 CFR Section 122.44(d)(1)(i), NPDES permits must contain limits that control all pollutants that “*are or may be discharged at a level which will cause, have the reasonable potential to cause, or contribute to an excursion above any state water quality standard, including state narrative criteria for water quality.*” Federal Regulations, 40 CFR, §122.44(d)(1)(vi), further provide that “[w]here a state has not established a water quality criterion for a specific chemical pollutant that is present in an effluent at a concentration that causes, has the reasonable potential to cause, or contributes to an excursion above a narrative criterion within an applicable State water quality standard, the permitting authority must establish effluent limits.”

The CWA requires point source discharges to control the amount of conventional, non-conventional, and toxic pollutants that are discharged into the waters of the United States. The control of pollutants discharged is established through effluent limitations and other requirements in NPDES permits. There are two principal bases for effluent limitations: 40 CFR §122.44(a) requires that permits include applicable technology-based limitations and standards, and 40 CFR §122.44(d) requires that permits include water quality-based effluent limitations to attain and maintain applicable numeric and narrative water quality criteria to protect the beneficial uses of the receiving water where numeric water quality objectives have not been established. The Regional Water Board’s Basin Plan, page IV-17.00, contains an implementation policy (“Policy for Application of Water Quality Objectives” that specifies that the Regional Water Board “*will, on a case-by-case basis, adopt numerical limitations in orders which will implement the narrative objectives.*” This Policy complies with 40 CFR §122.44(d)(1). With respect to narrative objectives, the Regional Water Board must establish effluent limitations using one or more of three specified sources, including (1) EPA’s published water quality criteria, (2) a proposed state criterion (*i.e.*, water quality objective) or an explicit state policy interpreting its narrative water quality criteria (*i.e.*, the Regional Water Board’s “Policy for Application of Water Quality Objectives”)(40 CFR 122.44(d)(1)(vi) (A), (B) or (C)), or (3) an indicator parameter. The Basin Plan contains a narrative objective requiring that: “*All waters shall be maintained free of toxic substances in concentrations that produce detrimental physiological responses in human, plant, animal, or aquatic life*” (narrative toxicity objective). The Basin Plan requires the application of the most stringent objective necessary to ensure that surface water and groundwater do not contain chemical constituents, discoloration, toxic substances,

radionuclides, or taste and odor producing substances that adversely affect beneficial uses. The Basin Plan states that material and relevant information, including numeric criteria, and recommendations from other agencies and scientific literature will be utilized in evaluating compliance with the narrative toxicity objective. The Basin Plan also limits chemical constituents in concentrations that adversely affect surface water beneficial uses. For waters designated as municipal, the Basin Plan specifies that, at a minimum, waters shall not contain concentrations of constituents that exceed Maximum Contaminant Levels (MCL) of CCR Title 22. The Basin Plan further states that, to protect all beneficial uses, the Regional Water Board may apply limits more stringent than MCLs.

A. Discharge Prohibitions

1. *As stated in section I.G of Attachment D, Standard Provisions, this Order prohibits bypass from any portion of the treatment facility. Federal Regulations, 40 CFR 122.41 (m), define "bypass" as the intentional diversion of waste streams from any portion of a treatment facility. This section of the Federal Regulations, 40 CFR 122.41 (m)(4), prohibits bypass unless it is unavoidable to prevent loss of life, personal injury, or severe property damage. In considering the Regional Water Board's prohibition of bypasses, the State Water Board adopted a precedential decision, Order No. WQO 2002-0015, which cites the Federal Regulations, 40 CFR 122.41(m), as allowing bypass only for essential maintenance to assure efficient operation.*

B. Technology-Based Effluent Limitations

1. Scope and Authority

The CWA requires that technology-based effluent limitations be established based on several levels of controls:

- Best practicable treatment control technology (BPT) represents the average of the best performance by plants within an industrial category or subcategory. BPT standards apply to toxic, conventional, and non-conventional pollutants.
- Best available technology economically achievable (BAT) represents the best existing performance of treatment technologies that are economically achievable within an industrial point source category. BAT standards apply to toxic and non-conventional pollutants.
- Best conventional pollutant control technology (BCT) represents the control from existing industrial point sources of conventional pollutants including BOD, TSS, fecal coliform, pH, and oil and grease. The BCT standard is established after considering the "cost reasonableness" of the relationship between the cost of attaining a reduction in effluent discharge and the benefits that would result, and also the cost effectiveness of additional industrial treatment beyond BPT.
- New source performance standards (NSPS) represent the best available demonstrated control technology standards. The intent of NSPS guidelines is to

set limitations that represent state-of-the-art treatment technology for new sources.

The CWA requires USEPA to develop effluent limitations, guidelines and standards (ELGs) representing application of BPT, BAT, BCT, and NSPS. Section 402(a)(1) of the CWA and section 125.3 of the Code of Federal Regulations authorize the use of best professional judgment (BPJ) to derive technology-based effluent limitations on a case-by-case basis where ELGs are not available for certain industrial categories and/or pollutants of concern. Where BPJ is used, the permit writer must consider specific factors outlined in section 125.3.

2. Applicable Technology-Based Effluent Limitations

The Discharger operates a “wet deck” log storage operation, a “barking” operation, and a “sawmills and planing mills” operation, however, there is no discharge from the wet deck or log deck. Therefore, effluent limitations established in Timber Products Processing Point Source Category (40 CFR Part 429) are applicable only to the wet deck discharge. Specifically, Subpart A (Barking Subcategory), Subpart I (Wet Storage Subcategory), and Subpart K (Sawmills and Planing Mills Subcategory) apply.

Except as provided in 40 CFR 125.30 through 125.32, any existing point source subject to this subpart must achieve the following effluent limitations representing the degree of effluent reduction attainable by the application of the best practicable control technology currently available (BPT). The following effluent limitations apply to Discharge Point 001:

- Barking - There shall be no discharge of process wastewater into navigable waters.
- Sawmills and Planing Mills - There shall be no discharge of process wastewater pollutants into navigable waters.
- Wet Storage - There shall be no debris discharged and the pH shall be within the range of 6.0 to 9.0 at all times. Where, “debris” means woody material such as bark, twigs, branches, heartwood or sapwood that will not pass through a 2.54 cm (1.0 in) diameter round opening and is present in the discharge from a wet storage facility.

Summary of Technology-based Effluent Limitations Discharge Point D-001

Table F-3. Summary of Technology-based Effluent Limitations

| Parameter | Units | Effluent Limitations | | | | |
|---|----------|----------------------|----------------|---------------|-----------------------|-----------------------|
| | | Average Monthly | Average Weekly | Maximum Daily | Instantaneous Minimum | Instantaneous Maximum |
| pH ¹ | pH units | | | | 6.0 | 9.0 |
| ¹ For log deck discharges only | | | | | | |

C. Water Quality-Based Effluent Limitations (WQBELs)

1. Scope and Authority

As specified in section 122.44(d)(1)(i), permits are required to include WQBELs for pollutants (including toxicity) that are or may be discharged at levels that cause, have reasonable potential to cause, or contribute to an in-stream excursion above any state water quality standard. The process for determining reasonable potential and calculating WQBELs when necessary is intended to protect the designated uses of the receiving water as specified in the Basin Plan, and achieve applicable water quality objectives and criteria that are contained in other state plans and policies, or any applicable water quality criteria contained in the CTR and NTR.

2. Applicable Beneficial Uses and Water Quality Criteria and Objectives

- a. **Receiving Water.** The receiving water for the Collins Pine Company Chester Sawmill is Stover Ditch, a tributary to Lake Almanor. The beneficial uses downstream of the discharge are hydropower generation, water contact recreation, freshwater habitat (cold and warm water), warm water spawning and wildlife habitat.
- b. **Hardness.** While no effluent limitation for hardness is necessary in this Order, hardness is critical to the assessment of the need for, and the development of, effluent limitations for certain metals. The *California Toxics Rule* and the *National Toxics Rule* contain water quality criteria for seven metals that vary as a function of hardness, the lower the hardness the lower the water quality criteria. The hardness-dependent metal criteria include cadmium, copper, chromium III, lead, nickel, silver, and zinc.

Effluent limitations for the discharge must be set to protect the beneficial uses of the receiving water for all discharge conditions. In the absence of the option of including condition-dependent, “floating” effluent limitations that are reflective of actual hardness conditions at the time of discharge, effluent limitations must be set using a reasonable worst-case condition in order to protect beneficial uses for all discharge conditions. The SIP does not address how to determine hardness for application to the equations for the protection of aquatic life when using hardness-dependent metals criteria. It simply states, in Section 1.2, that the criteria shall be properly adjusted for hardness using the hardness of the

receiving water. The CTR requires that, for waters with a hardness of 400 mg/L (as CaCO₃), or less, the actual ambient hardness of the surface water must be used. It further requires that the hardness values used must be consistent with the design discharge conditions for design flows and mixing zones.¹ The CTR does not define whether the term “ambient,” as applied in the regulations, necessarily requires the consideration of upstream as opposed to downstream hardness conditions.

The point in the receiving water affected by the discharge is downstream of the discharge. As the effluent mixes with the receiving water, the hardness of the receiving water can change. Therefore, it is appropriate to use the ambient hardness downstream of the discharge that is a mixture of the effluent and receiving water for the determination of the CTR hardness-dependent metals criteria. Recent studies indicate that using the lowest recorded receiving water hardness for establishing water quality criteria is not always protective of the receiving water under various mixing conditions (e.g. when the effluent hardness is less than the receiving water hardness). The studies evaluated the relationships between hardness and the CTR metals criterion that is calculated using the CTR metals equation. The equation describing the total recoverable regulatory criterion, as established in the CTR, is as follows:

$$\text{CTR Criterion} = e^{m[\ln(H)]+b} \quad (\text{Equation 1})$$

Where:

- H = Design Hardness
- b = metal- and criterion-specific constant
- m = metal- and criterion-specific constant

The constants “m” and “b” are specific to both the metal under consideration, and the type of total recoverable criterion (i.e. acute or chronic). The metal-specific values for these constants are provided in the CTR at paragraph (b)(2), Table 1.

The relationship between the Design Hardness and the resulting criterion in Equation 1 can exhibit either a downward-facing (i.e., concave downward) or an upward-facing (i.e., concave upward) curve depending on the values of the criterion-specific constants. The curve shapes for acute and chronic criteria for the metals are as follows:

Concave Downward: cadmium (chronic), chromium (III), copper, nickel, and zinc

Concave Upward: cadmium (acute), lead, and silver (acute)

For those contaminants where the regulatory criteria exhibit a concave downward relationship as a function of hardness, use of the lowest recorded effluent

¹ See 40 CFR 131.38(c)(4)(i)

hardness for establishment of water quality objectives is fully protective of all beneficial uses regardless of whether the effluent or receiving water hardness is higher. Use of the lowest recorded effluent hardness is also protective under all possible mixing conditions between the effluent and the receiving water (i.e., from high dilution to no dilution). Therefore, for cadmium (chronic), chromium (III), copper, nickel, and zinc, the reasonable worst-case ambient hardness can be estimated by using the lowest effluent hardness. The water quality criteria for these metals were calculated for this Order using Equation 1 and a reported minimum effluent hardness of 107 mg/L as CaCO₃, based on 5 samples obtained by the Discharger between January 2005 and July 2008.

For those metals where the regulatory criteria exhibit a concave upward relationship as a function of hardness, water quality objectives based on either the effluent hardness or the receiving water hardness alone, would not be protective under all mixing scenarios. Instead, both the hardness of the upstream receiving water and the effluent is required to determine the reasonable worst-case ambient hardness. In this case, using the lowest upstream receiving water hardness in Equation 2, below, is protective if the effluent hardness is ALWAYS higher than the receiving water hardness. Under circumstances where the effluent hardness is not ALWAYS higher than the receiving water hardness, it may be appropriate to use the highest reported upstream receiving water hardness in Equation 2. The following equation provides fully protective water quality criteria for those metals that exhibit a concave upward relationship.

$$\text{CTR Criterion} = \left[\frac{m}{H_{rw}} \cdot (H_{eff} - H_{rw}) + 1 \right] \cdot e^{m \cdot \ln(H_{rw}) + b} \quad (\text{Equation 2})$$

Where:

- H_{eff} = effluent hardness
- H_{rw} = upstream receiving water hardness
- b = metal- and criterion-specific constant
- m = metal- and criterion-specific constant

Therefore, for cadmium (acute), lead, and silver (acute) water quality criteria were calculated using Equation 2 with a lowest reported effluent hardness of 107 mg/L as CaCO₃ and a **lowest** reported upstream receiving water hardness of 48 mg/L as CaCO₃, based on 2 samples from January 2005 to July 2008.

- c. Assimilative Capacity/Mixing Zone.** Based on the available information, the worst-case dilution is assumed to be zero to provide protection for the receiving water beneficial uses. The impact of assuming zero dilution/assimilative capacity within the receiving water is that the discharge limitations are end-of-pipe limits with no allowance for dilution within the receiving water.

3. Determining the Need for WQBELs

- a. CWA section 301 (b)(1) requires NPDES permits to include effluent limitations that achieve technology-based standards and any more stringent limitations necessary to meet water quality standards. Water quality standards include Regional Water Board Basin Plan beneficial uses and narrative and numeric water quality objectives, State Water Board-adopted standards, and federal standards, including the CTR and NTR. The Basin Plan includes numeric site-specific water quality objectives and narrative objectives for toxicity, chemical constituents, and tastes and odors. The narrative toxicity objective states: *“All waters shall be maintained free of toxic substances in concentrations that produce detrimental physiological responses in human, plant, animal, or aquatic life.”* (Basin Plan at III-8.00.) With regards to the narrative chemical constituent’s objective, the Basin Plan states that waters shall not contain chemical constituents in concentrations that adversely affect beneficial uses. At minimum, *“...water designated for use as domestic or municipal supply (MUN) shall not contain concentrations of chemical constituents in excess of the maximum contaminant levels (MCLs)”* in Title 22 of CCR. The narrative tastes and odors objective states: *“Water shall not contain taste- or odor-producing substances in concentrations that impart undesirable tastes or odors to domestic or municipal water supplies or to fish flesh or other edible products of aquatic origin, or that cause nuisance, or otherwise adversely affect beneficial uses.”*

- b. Federal regulations require effluent limitations for all pollutants that are or may be discharged at a level that will cause or have the reasonable potential to cause, or contribute to an in-stream excursion above a narrative or numerical water quality standard. Based on information submitted as part of the application, in studies, and as directed by monitoring and reporting programs, the Regional Water Board finds that the discharge has a reasonable potential to cause or contribute to an in-stream excursion above a water quality standard for copper and lead. Water quality-based effluent limitations (WQBELs) for these constituents are included in this Order. A summary of the reasonable potential analysis (RPA) is provided in Table F-4, and a detailed discussion of the RPA for each constituent is provided below. The Discharger has changed their process control, due to some cyanide detections in the effluent. Since February 2007, all cyanide effluent samples have been at non-detectable levels, therefore, no effluent limitation was set for cyanide. Since the February 2007, there has been no reasonable potential for exceedance of cyanide in the effluent. This Order will require additional monitoring, and if there is a reasonable potential for cyanide, than the Order will be reopened and effluent limits will be assigned to the CTR parameters as applicable.

- c. The Regional Water Board conducted the RPA in accordance with Section 1.3 of the SIP. Although the SIP applies directly to the control of CTR priority pollutants, the State Water Board has held that the Regional Water Board may

use the SIP as guidance for water quality-based toxics control.² The SIP states in the introduction “*The goal of this Policy is to establish a standardized approach for permitting discharges of toxic pollutants to non-ocean surface waters in a manner that promotes statewide consistency.*” Therefore, in this Order the RPA procedures from the SIP were used to evaluate reasonable potential for both CTR and non-CTR constituents.

- d. WQBELs were calculated in accordance with section 1.4 of the SIP, as described in Attachment F, Section IV.C.4.

² See, Order WQO 2001-16 (Napa) and Order WQO 2004-0013 (Yuba City)

Table F-4. Summary of Reasonable Potential Analysis

| Parameter | Units | No. Effluent Samples | MEC | No. Receiving Water Samples | <u>BC</u> | Most Stringent Applicable Criterion <u>C</u> | Criterion | Basis for Reasonable Potential Determination |
|-----------|-------|----------------------|------|-----------------------------|-----------|---|----------------------|--|
| Copper | ug/l | 6 | 16.4 | 2 | 0.3 | 9.88 | Chronic aquatic life | MEC>C |
| Lead | ug/l | 5 | 4.6 | 2 | <0.1 | 3.47 | Chronic aquatic life | MEC>C |

MEC = maximum effluent concentration (data set from January 2005 to January 2008).

BC = maximum background concentration (receiving water data set from January 2005 to January 2008).

Table F-5. Summary of Applicable Priority Pollutant Criterion/Objectives

| | | CTR Water Quality Criteria | | | | Basin Plan | | Most Stringent Applicable Criterion (C) | |
|---------------------|-------|----------------------------|---------------|----------------------------------|----------------|-------------|---------------|---|---------|
| | | Freshwater | | Human Health for consumption of: | | Max (acute) | Max (chronic) | | |
| Parameter | Units | CMC (acute) | CCC (chronic) | Water & Organisms (W&O) | Organisms Only | | | | |
| Copper ¹ | ug/l | 14.92 | 9.88 | 1300 | -- | | -- | 9.88 | CTR CCC |
| Lead | ug/l | 89.0 | 3.468 | -- | -- | 15 | -- | 3.468 | CTR CCC |

¹ Based on water hardness of 107 mg/L, pH value of 6.6.

CTR = California Toxic Rule

CMC = Criterion Maximum Concentration (acute)

CCC = Criterion Continuous Concentration (chronic)

ML= Minimum quantifiable level required by Appendix 4 of the SIP

- e. **Chemical Oxygen Demand.** This Order contains a daily maximum chemical oxygen demand of 40 mg/L. This is consistent with the previous Order.
- f. **Copper.** The CTR includes hardness-dependent criteria for the protection of freshwater aquatic life for copper. The criteria for copper are presented in dissolved concentrations. USEPA recommends conversion factors to translate dissolved concentrations to total concentrations. The USEPA default conversion factors for copper in freshwater are 0.96 for both the acute and the chronic criteria. Using the worst-case measured hardness from the effluent (107 mg/L as CaCO₃) and the USEPA recommended dissolved-to-total translator, the applicable chronic criterion (maximum four-day average concentration) is 9.88 µg/L and the applicable acute criterion (maximum one-hour average concentration) is 14.92 µg/L, as total recoverable.

The MEC for total copper was 16.4 µg/L, based on six samples collected between January 2005 and January 2008, while the maximum observed upstream receiving water total copper concentration was 0.3 µg/L, based on two samples collected between January 2005 and January 2008. Therefore, the discharge has a reasonable potential to cause or contribute to an in-stream excursion above the CTR criteria for copper. There are no dilution credits proposed for the discharge. An AMEL and MDEL for total copper of 7.44 µg/L and 14.92 µg/L, respectively, are included in this Order based on CTR criteria for the protection of freshwater aquatic life (See Attachment F, Table F-7 for WQBEL calculations).

The Discharger is unable to comply with these limitations. Section 2.1 of the SIP allows for compliance schedules within the permit for existing discharges where it is demonstrated that it is infeasible for a Discharger to achieve immediate compliance with a CTR criterion. Using the statistical methods for calculating interim effluent limitations described in Attachment F, Section IV.D.1., an interim performance-based maximum daily limitation of 31.16 µg/L was calculated.

Section 2.1 of the SIP provides that: *“Based on an existing discharger’s request and demonstration that it is infeasible for the discharger to achieve immediate compliance with a CTR criterion, or with an effluent limitation based on a CTR criterion, the RWQCB may establish a compliance schedule in an NPDES permit.”* Section 2.1, further states that compliance schedules may be included in NPDES permits provided that the following justification has been submitted: *...“(a) documentation that diligent efforts have been made to quantify pollutant levels in the discharge and the sources of the pollutant in the waste stream; (b) documentation of source control measures and/or pollution minimization measures efforts currently underway or completed; (c) a proposal for additional or future source control measures, pollutant minimization actions, or waste treatment (i.e., facility upgrades); and (d) a demonstration that the proposed schedule is as short as practicable.”* The new water quality-based effluent limitations for copper become effective on **May 18, 2010**.

This Order requires the Discharger to submit a corrective action plan and implementation schedule to assure compliance with the final copper effluent limitations. The interim effluent limitations are in effect through **May 17, 2010**. As part of the compliance schedule for copper, the Discharger shall develop a pollution prevention program in compliance with CWC section 13263.3(d)(3).

- g. **Electrical Conductivity. (see Subsection jj. Salinity)**
- h. **Lead.** The CTR includes hardness-dependent standards for the protection of freshwater aquatic life for lead. The standards for metals are presented in dissolved concentrations. USEPA recommends conversion factors to translate dissolved concentrations to total concentrations. The conversion factors for lead in freshwater are $1.46203 - [0.145712 \times \ln(\text{hardness})]$ for both the acute and the chronic criteria. Using the worst-case measured hardness from the effluent (107 mg/L), the applicable chronic criterion (maximum four-day average concentration) is 3.468 µg/L and the applicable acute criterion (maximum one-hour average concentration) is 89.0 µg/L, as total recoverable.

The MEC for total lead was 4.6 µg/L, based on five samples collected between January 2004 and January 2008, while the maximum observed upstream receiving water total lead concentration was <0.1 µg/L, based on two samples collected between January 2004 and January 2008. Therefore, the discharge has a reasonable potential to cause or contribute to an in-stream excursion above the CTR criteria for lead.

An AMEL and MDEL for total lead of 2.95 µg/L and 5.92 µg/L, respectively, are included in this Order based on CTR criteria for the protection of freshwater aquatic life (See Attachment F, Table F-8 for WQBEL calculations).

Based on the sample results in the effluent, it appears that the Discharger is unable to comply with these limitations. Section 2.1 of the SIP allows for compliance schedules within the permit for existing discharges where it is demonstrated that it is infeasible for a Discharger to achieve immediate compliance with a CTR criterion. Using the statistical methods for calculating interim effluent limitations described in Attachment F, Section IV.D.1., an interim performance-based maximum daily limitation of 8.74 µg/L was calculated.

Section 2.1 of the SIP provides that: *“Based on an existing discharger’s request and demonstration that it is infeasible for the discharger to achieve immediate compliance with a CTR criterion, or with an effluent limitation based on a CTR criterion, the RWQCB may establish a compliance schedule in an NPDES permit.”* Section 2.1, further states that compliance schedules may be included in NPDES permits provided that the following justification has been submitted: *...“(a) documentation that diligent efforts have been made to quantify pollutant levels in the discharge and the sources of the pollutant in the waste stream; (b) documentation of source control measures and/or pollution minimization*

measures efforts currently underway or completed; (c) a proposal for additional or future source control measures, pollutant minimization actions, or waste treatment (i.e., facility upgrades); and (d) a demonstration that the proposed schedule is as short as practicable.” The new water quality-based effluent limitations for lead become effective on **May 18, 2010**.

This Order requires the Discharger to submit a corrective action plan and implementation schedule to assure compliance with the final lead effluent limitations. The interim effluent limitations are in effect through **May 17, 2010**. As part of the compliance schedule for lead, the Discharger shall develop a pollution prevention program in compliance with CWC section 13263.3(d)(3).

- i. **pH.** This Order requires the effluent pH to remain between 6.0 and 9.0 pH units. These limits are consistent with the previous permit, and Timber Products Processing Point Source Category, Wet Storage Subcategory (40 CFR Part 429, Subpart I). Effluent Limitations for pH are included in this Order based on the requirements in the CFR for pH.
- j. **Salinity.** The discharge contains suspended solids, settleable solids, and electrical conductivity (EC). These are water quality parameters that are indicative of the salinity of the water. Their presence in water can be growth limiting to certain agricultural crops and can affect the taste of water for human consumption. There are no USEPA water quality criteria for the protection of aquatic organisms for these constituents. The Basin Plan contains a chemical constituent objective that incorporates State MCLs, contains a narrative objective, and contains numeric water quality objectives for EC.

Table F-6. Salinity Water Quality Criteria/Objectives

| Parameter | Agricultural WQ Goal ¹ | Secondary MCL ³ | Basin Plan (D-1641) ⁴ | Effluent | |
|---------------|-----------------------------------|----------------------------|---|----------|-----|
| | | | | Avg | Max |
| EC (µmhos/cm) | 700 ² | 900, 1600, 2200 | 700 (1 Apr – 31 Aug) 1000 (1 Sep – 31 Mar) | 366 | 570 |

- 1 Agricultural water quality goals based on *Water Quality for Agriculture*, Food and Agriculture Organization of the United Nations—Irrigation and Drainage Paper No. 29, Rev. 1 (R.S. Ayers and D.W. Westcot, Rome, 1985)
- 2 Agricultural water quality goals listed provide no restrictions on crop type or irrigation methods for maximum crop yield. Higher concentrations may require special irrigation methods to maintain crop yields or may restrict types of crops grown.
- 3 The secondary MCLs are stated as a recommended level, upper level, and a short-term maximum level.
- 4 The D-1641 water quality objectives apply at three monitoring locations in the South Delta. They do not apply to the entire Delta.

- i. **Electrical Conductivity (EC).** The secondary MCL for EC is 900 µmhos/cm as a recommended level, 1600 µmhos/cm as an upper level, and 2200 µmhos/cm as a short-term maximum. The agricultural water quality goal, that would apply the narrative chemical constituents objective, is 700 µmhos/cm as a long-term average based on Water Quality for

Agriculture, Food and Agriculture Organization of the United Nations—
Irrigation and Drainage Paper No. 29, Rev. 1 (R.S. Ayers and D.W. Westcot,
Rome, 1985). The 700 $\mu\text{mhos/cm}$ agricultural water quality goal is intended
to prevent reduction in crop yield, i.e. a restriction on use of water, for salt-
sensitive crops, such as beans, carrots, turnips, and strawberries. These
crops are neither currently grown in the area or may not be grown in the
future. Most other crops can tolerate higher EC concentrations without
harm, however, as the salinity of the irrigation water increases, more crops
are potentially harmed by the EC, or extra measures must be taken by the
farmer to minimize or eliminate any harmful impacts.

A review of the Discharger's monitoring reports from January 2005 through
June 2008 shows an average effluent EC of 366 $\mu\text{mhos/cm}$, with a range
from 251 $\mu\text{mhos/cm}$ to 570 $\mu\text{mhos/cm}$ for 102 monthly samples. These levels
do not exceed the applicable objectives. The background receiving water EC
averaged 84 $\mu\text{mhos/cm}$ in 102 sampling events collected by the Discharger
from January 2005 through June 2008. These data show that the receiving
water frequently has assimilative capacity for EC.

- e. **Settleable Solids.** For inland surface waters, the Basin Plan states that “[w]ater shall not contain substances in concentrations that result in the deposition of material that causes nuisance or adversely affects beneficial uses.” This Order contains average monthly and average daily effluent limitations for settleable solids, which is consistent with the previous order.

Because the amount of settleable solids is measured in terms of volume per volume without a mass component, it is impracticable to calculate mass limitations for inclusion in this Order. A daily maximum effluent limitation for settleable solids is included in the Order, in lieu of a weekly average, to ensure that the treatment works operate in accordance with design capabilities.

- f. **Suspended Solids.** For inland surface waters, the Basin Plan states that “[w]ater shall not contain suspended material substances in concentrations that cause nuisance or adversely affects beneficial uses.” This Order contains maximum daily effluent limitations for suspended solids, which is consistent with the previous order.

Because the amount of settleable solids is measured in terms of volume per volume without a mass component, it is impracticable to calculate mass limitations for inclusion in this Order. A daily maximum effluent limitation for settleable solids is included in the Order, in lieu of a weekly average, to ensure that the treatment works operate in accordance with design capabilities.

- g. **Toxicity.** See Section IV.C.5. of the Fact Sheet regarding whole effluent toxicity.

4. WQBEL Calculations

- a. Effluent limitations for copper and lead were calculated in accordance with section 1.4 of the SIP. The following paragraphs describe the methodology used for calculating effluent limitations.
- b. **Effluent Limitation Calculations.** In calculating maximum effluent limitations, the effluent concentration allowances were set equal to the criteria/standards/objectives.

$$ECA_{acute} = CMC \qquad ECA_{chronic} = CCC$$

For the human health, agriculture, or other long-term criterion/objective, a dilution credit can be applied. The ECA is calculated as follows:

$$ECA_{HH} = HH + D(HH - B)$$

where:

ECA_{acute} = effluent concentration allowance for acute (one-hour average) toxicity criterion

$ECA_{chronic}$ = effluent concentration allowance for chronic (four-day average) toxicity criterion

ECA_{HH} = effluent concentration allowance for human health, agriculture, or other long-term criterion/objective

CMC = criteria maximum concentration (one-hour average)

CCC = criteria continuous concentration (four-day average, unless otherwise noted)

HH = human health, agriculture, or other long-term criterion/objective

D = dilution credit

B = maximum receiving water concentration

Acute and chronic toxicity ECAs were then converted to equivalent long-term averages (LTA) using statistical multipliers and the lowest is used. Additional statistical multipliers were then used to calculate the maximum daily effluent limitation (MDEL) and the average monthly effluent limitation (AMEL).

Human health ECAs are set equal to the AMEL and a statistical multiplier is used to calculate the MDEL.

$$AMEL = mult_{AMEL} \left[\min \left(M_A ECA_{acute}, M_C ECA_{chronic} \right) \right] \quad LTA_{acute}$$

$$MDEL = mult_{MDEL} \left[\min \left(M_A ECA_{acute}, M_C ECA_{chronic} \right) \right] \quad LTA_{chronic}$$

$$MDEL_{HH} = \left(\frac{mult_{MDEL}}{mult_{AMEL}} \right) AMEL_{HH}$$

where: mult_{AMEL} = statistical multiplier converting minimum LTA to AMEL
 mult_{MDEL} = statistical multiplier converting minimum LTA to MDEL
 M_A = statistical multiplier converting CMC to LTA
 M_C = statistical multiplier converting CCC to LTA

Water quality-based effluent limitations were calculated for copper and lead as follows in Tables F-7 through F-10, below.

Table F-7 WQBEL Calculations for Copper

| | Acute | Chronic | Human Health |
|---|----------------------|---------------------|---------------|
| Criteria (µg/L) | 14.92 ⁽¹⁾ | 9.88 ⁽²⁾ | 1300 |
| Dilution Credit | No Dilution | No Dilution | No Dilution |
| ECA | 14.92 | 9.88 | 1300 |
| ECA Multiplier ⁽³⁾ | 0.321 | 0.527 | -- |
| LTA | 4.791 | 5.213 | -- |
| AMEL Multiplier (95 th %) ^{(4) (5)} | 1.55 | ⁽⁷⁾ | -- |
| AMEL (µg/L) | 7.44 | ⁽⁷⁾ | 1300.0 |
| MDEL Multiplier (99 th %) ⁽⁶⁾ | 3.11 | ⁽⁷⁾ | 2.01 |
| MDEL (µg/L) | 14.92 | ⁽⁷⁾ | 2608.0 |

- (1) Basin Plan aquatic life criteria, based on a hardness of 107 mg/L as CaCO₃ .
- (2) CTR aquatic life criteria, based on a hardness of 107 mg/L as CaCO₃.
- (3) Acute and Chronic ECA Multiplier calculated at 99th percentile per section 1.4.B, Step 3 of SIP or per sections 5.4.1 and 5.5.4 of the TSD.
- (4) Assumes sampling frequency n=>4.
- (5) The probability basis for AMEL is 95th percentile per section 1.4.B, Step 5 of SIP or section 5.5.4 of the TSD.
- (6) The probability basis for MDEL is 99th percentile per section 1.4.B, Step 5 of SIP or section 5.5.4 of the TSD.
- (7) Limitations based on acute LTA (Acute LTA < Chronic LTA).

Table F-8 WQBEL Calculations for Lead

| | Acute | Chronic |
|---|---------------------|----------------------|
| Criteria (µg/L) | 89.0 ⁽¹⁾ | 3.468 ⁽²⁾ |
| Dilution Credit | No Dilution | No Dilution |
| ECA | 88.989 | 3.603 |
| ECA Multiplier ⁽³⁾ | 0.321 | 0.527 |
| LTA | 28.573 | 1.900 |
| AMEL Multiplier (95 th %) ^{(4) (5)} | ⁽⁷⁾ | 1.55 |
| AMEL (µg/L) | ⁽⁷⁾ | 2.95 |
| MDEL Multiplier (99 th %) ⁽⁶⁾ | ⁽⁷⁾ | 3.11 |
| MDEL (µg/L) | ⁽⁷⁾ | 5.92 |

- (1) Basin Plan aquatic life criteria, based on a hardness of 107 mg/L as CaCO₃ .
- (2) CTR aquatic life criteria, based on a hardness of 107 mg/L as CaCO₃.
- (3) Acute and Chronic ECA Multiplier calculated at 99th percentile per section 1.4.B, Step 3 of SIP or per sections 5.4.1 and 5.5.4 of the TSD.
- (4) Assumes sampling frequency n=>4.
- (5) The probability basis for AMEL is 95th percentile per section 1.4.B, Step 5 of SIP or section 5.5.4 of the TSD.
- (6) The probability basis for MDEL is 99th percentile per section 1.4.B, Step 5 of SIP or section 5.5.4 of the TSD.
- (7) Limitations based on chronic LTA (Chronic LTA < Acute LTA).

Table F-9 WQBEL Calculation Summary Table

| Parameter | Units | Criterion | ECA | CV | ECA multiplier | LTA | Most limiting LTA | AMEL aq. | MDEL aq. | AMEL hh | MDEL hh |
|-----------|-------|----------------------|--------|-----|----------------|--------|-------------------|----------|----------|---------|---------|
| Copper | ug/l | Acute aquatic life | 14.920 | | 0.321 | 4.791 | 4.791 | 7.44 | 14.92 | 1300 | 2608 |
| | | Chronic aquatic life | 9.88 | 0.6 | 0.527 | 5.213 | -- | | | | |
| | | Human Health | 1300 | | n/a | -- | -- | | | | |
| Lead | ug/l | Acute aquatic life | 88.989 | 0.6 | 0.321 | 28.573 | -- | 2.95 | 5.92 | n/a | n/a |
| | | Chronic aquatic life | 3.603 | | 0.527 | 1.900 | 1.900 | | | | |

⁽¹⁾ Final AMEL and MDEL are shaded for each parameter.
n/a Not Applicable

**Summary of Water Quality-based Effluent Limitations
Discharge Point D-001**

Table F-10. Summary of Water Quality-based Effluent Limitations

| Parameter | Units | Effluent Limitations | | | | |
|-----------|----------------|----------------------|----------------|---------------|-----------------------|-----------------------|
| | | Average Monthly | Average Weekly | Maximum Daily | Instantaneous Minimum | Instantaneous Maximum |
| Copper | ug/L | 7.44 | -- | 14.92 | -- | -- |
| Lead | ug/L | 2.95 | -- | 5.92 | | |
| pH | standard units | -- | -- | -- | 6.0 | 9.0 |

5. Whole Effluent Toxicity (WET)

For compliance with the Basin Plan’s narrative toxicity objective, this Order requires the Discharger to conduct whole effluent toxicity testing for acute and chronic toxicity, as specified in the Monitoring and Reporting Program (Attachment E, Section V.). This Order also contains effluent limitations for acute toxicity and requires the Discharger to implement best management practices to investigate the causes of, and identify corrective actions to reduce or eliminate effluent toxicity.

- a. **Acute Aquatic Toxicity.** The Basin Plan contains a narrative toxicity objective that states, “All waters shall be maintained free of toxic substances in concentrations that produce detrimental physiological responses in human, plant, animal, or aquatic life.” (Basin Plan at III-8.00) The Basin Plan also states that, “...effluent limits based upon acute biotoxicity tests of effluents will be prescribed where appropriate...”. USEPA Region 9 provided guidance for the development

of acute toxicity effluent limitations in the absence of numeric water quality objectives for toxicity in its document titled "Guidance for NPDES Permit Issuance", dated February 1994. In section B.2. "Toxicity Requirements" (pgs. 14-15) it states that, "*In the absence of specific numeric water quality objectives for acute and chronic toxicity, the narrative criterion 'no toxics in toxic amounts' applies. Achievement of the narrative criterion, as applied herein, means that ambient waters shall not demonstrate for acute toxicity: 1) less than 90% survival, 50% of the time, based on the monthly median, or 2) less than 70% survival, 10% of the time, based on any monthly median. For chronic toxicity, ambient waters shall not demonstrate a test result of greater than 1 TUc.*" Accordingly, effluent limitations for acute toxicity have been included in this Order as follows:

Acute Toxicity. Survival of aquatic organisms in 96-hour bioassays of undiluted waste shall be no less than:

| | |
|--|-----|
| Minimum for any one bioassays ----- | 70% |
| Median for any three or more consecutive bioassays ----- | 90% |

Chronic Aquatic Toxicity. The Basin Plan contains a narrative toxicity objective that states, "All waters shall be maintained free of toxic substance in concentrations that produce detrimental physiological responses in human, plant, animal, or aquatic life." (Basin Plan at III-8.00). Based on semi-annual whole effluent chronic toxicity testing performed by the Discharger from January 2004 through January 2008, the discharge has reasonable potential to cause or contribute to an in-stream excursion above of the Basin Plan's narrative toxicity objective.

No dilution has been granted for the chronic condition. Therefore, chronic toxicity testing results exceeding 1 chronic toxicity unit (TUc) demonstrates the discharge has a reasonable potential to cause or contribute to an exceedance of the Basin Plan's narrative toxicity objective.

To ensure compliance with the Basin Plan's narrative toxicity objective, the Discharger is required to conduct chronic whole effluent toxicity testing, as specified in the Monitoring and Reporting Program (Attachment E, Section V.). Furthermore, Special Provisions VI.C.2.a. of this Order requires the Discharger to investigate the causes of, and identify and implement corrective actions to reduce or eliminate effluent toxicity. If the discharge demonstrates a pattern of toxicity exceeding the numeric toxicity monitoring trigger, the Discharger is required to initiate a Toxicity Reduction Evaluation (TRE), in accordance with an approved TRE work plan. The numeric toxicity monitoring trigger is not an effluent limitation, it is the toxicity threshold at which the Discharger is required to perform accelerated chronic toxicity monitoring, as well as, the threshold to initiate a TRE if a pattern of effluent toxicity has been demonstrated.

D. Final Effluent Limitations

1. Mass-based Effluent Limitations.

Title 40 CFR 122.45(f)(1) requires effluent limitations be expressed in terms of mass, with some exceptions, and 40 CFR 122.45(f)(2) allows pollutants that are limited in terms of mass to additionally be limited in terms of other units of measurement. This Order includes effluent limitations expressed in terms of mass and concentration. In addition, pursuant to the exceptions to mass limitations provided in 40 CFR 122.45(f)(1), some effluent limitations are not expressed in terms of mass, such as pH and temperature, and when the applicable standards are expressed in terms of concentration (e.g. CTR criteria and MCLs) and mass limitations are not necessary to protect the beneficial uses of the receiving water.

Mass-based effluent limitations were calculated by multiplying the concentration limitation by the Facility's reasonable measure of actual flow and the appropriate unit conversion factor. Based on flow monitoring data submitted by the Discharger from January 2005 through June 2008 the long-term average flow is 0.36 mgd. Consistent with 40 CFR 122.45(b)(2)(i), the reasonable measure of actual flow for the Facility is 0.36 mgd. Unless otherwise noted, all mass limitations or mass emission rates (MERs) in this Order were calculated using the reasonable measure of actual flow.

2. Averaging Periods for Effluent Limitations.

Title 40 CFR 122.45 (d) requires average weekly and average monthly discharge limitations for continuous discharges unless impracticable. However, for toxic pollutants and pollutant parameters in water quality permitting, the US EPA recommends the use of a maximum daily effluent limitation in lieu of average weekly effluent limitations for two reasons. *"First, the basis for the 7-day average for POTWs derives from the secondary treatment requirements. This basis is not related to the need for assuring achievement of water quality standards. Second, a 7-day average, which could comprise up to seven or more daily samples, could average out peak toxic concentrations and therefore the discharge's potential for causing acute toxic effects would be missed."* (TSD, pg. 96) This Order utilizes maximum daily effluent limitations in lieu of average weekly effluent limitations for copper and lead, as recommended by the TSD for the achievement of water quality standards and for the protection of the beneficial uses of the receiving stream. Furthermore, pH weekly average effluent limitations have been replaced or supplemented with effluent limitations utilizing shorter averaging periods. The rationale for using shorter averaging periods for these constituents is discussed in Attachment F, Section IV.C.3., above.

3. Satisfaction of Anti-Backsliding Requirements.

All effluent limitations in this Order are at least as stringent as the effluent limitations in the previous Order.

4. Satisfaction of Antidegradation Policy

The permitted discharge is consistent with the antidegradation provisions of 40 CFR 131.12 and State Water Board Resolution 68-16. Compliance with these requirements will result in the use of best practicable treatment or control of the discharge. The impact on existing water quality will be insignificant.

Summary of Final Effluent Limitations Discharge Point EFF-001

Table F-11. Summary of Final Effluent Limitations

| Parameter | Units | Effluent Limitations | | | | |
|---------------------------|----------|----------------------|----------------|---------------|------------------|------------------|
| | | Average Monthly | Average Weekly | Maximum Daily | Instant. Minimum | Instant. Maximum |
| Average Dry Weather Flow | mgd | 0.36 | -- | -- | -- | -- |
| Suspended Solids | mg/L | -- | -- | 40 | -- | -- |
| Settleable Solids | mL/L | 0.1 | -- | 0.2 | -- | -- |
| Specific Conductance | umhos/cm | -- | -- | 900 | -- | -- |
| Chemical Oxygen Demand | mg/L | -- | -- | 40 | -- | -- |
| pH | -- | -- | -- | -- | 6.0 | 9.0 |
| Copper, Total Recoverable | ug/L | 7.44 | -- | 14.92 | -- | -- |
| Lead, Total Recoverable | ug/L | 2.95 | -- | 5.92 | -- | -- |

E. Interim Effluent Limitations

Copper and Lead. The SIP, section 2.2.1, requires that if a compliance schedule is granted for a CTR or NTR constituent, the Regional Water Board shall establish interim requirements and dates for their achievement in the NPDES permit. The interim limitations must be based on current treatment plant performance or existing permit limitations, whichever is more stringent. The State Water Board has held that the SIP may be used as guidance for non-CTR constituents. Therefore, the SIP requirement for interim effluent limitations has been applied to both CTR and non-CTR constituents in this Order.

The interim limitations for copper and lead in this Order are based on the current treatment plant performance. In developing the interim limitation, where there are ten sampling data points or more, sampling and laboratory variability is accounted for by establishing interim limits that are based on normally distributed data where 99.9% of the data points will lie within 3.3 standard deviations of the mean (*Basic Statistical Methods for Engineers and Scientists, Kennedy and Neville, Harper and Row*).

Therefore, the interim limitations in this Order are established as the mean plus 3.3 standard deviations of the available data.

When there are less than ten sampling data points available, the *Technical Support Document for Water Quality- Based Toxics Control* ((EPA/505/2-90-001), TSD) recommends a coefficient of variation of 0.6 be utilized as representative of wastewater effluent sampling. The TSD recognizes that a minimum of ten data points is necessary to conduct a valid statistical analysis. The multipliers contained in Table 5-2 of the TSD are used to determine a maximum daily limitation based on a long-term average objective. In this case, the long-term average objective is to maintain, at a minimum, the current plant performance level. Therefore, when there are less than ten sampling points for a constituent, interim limitations are based on 3.11 times the maximum observed effluent concentration to obtain the daily maximum interim limitation (MDEL) and 1.90 times the maximum observed effluent concentration to obtain the average monthly interim limitation (AMEL) (TSD, Table 5-2). The AMEL and MDEL multipliers are based on the 99th percentile confidence interval in recognition of the discharger’s concern that actual copper effluent concentration variability is greater than reflected in the limited sample set available at this time. The Discharger can currently meet the final MDEL for copper and lead but is unable to meet the final AMEL for copper and lead. Therefore, only an interim limitation for the AMEL has been calculated.

The Regional Water Board finds that the Discharger can undertake source control and treatment plant measures to maintain compliance with the interim limitations included in this Order. Interim limitations are established when compliance with effluent limitations cannot be achieved by the existing discharge. Discharge of constituents in concentrations in excess of the final effluent limitations, but in compliance with the interim effluent limitations, can significantly degrade water quality and adversely affect the beneficial uses of the receiving stream on a long-term basis. The interim limitations, however, establish an enforceable ceiling concentration until compliance with the effluent limitation can be achieved.

Table F-12 summarizes the calculations of the interim effluent limitations for copper and lead:

Table F-12. Interim Effluent Limitation Calculation Summary

| Parameter | MEC | Mean | Std. Dev. | # of Samples | Interim Limitation |
|-----------|------|-------|-----------|--------------|--------------------|
| Copper | 16.4 | 15.15 | 1.70 | 2 | 31.16 |
| Lead | 4.6 | 4.07 | 0.71 | 2 | 8.74 |

F. Land Discharge Specifications – Not Applicable

G. Reclamation Specifications – Not Applicable

V. RATIONALE FOR RECEIVING WATER LIMITATIONS

Basin Plan water quality objectives to protect the beneficial uses of surface water and groundwater include numeric objectives and narrative objectives, including objectives for chemical constituents, toxicity, and tastes and odors. The toxicity objective requires that surface water and groundwater be maintained free of toxic substances in concentrations that produce detrimental physiological responses in humans, plants, animals, or aquatic life. The chemical constituent objective requires that surface water and groundwater shall not contain chemical constituents in concentrations that adversely affect any beneficial use or that exceed the maximum contaminant levels (MCLs) in Title 22, CCR. The tastes and odors objective states that surface water and groundwater shall not contain taste- or odor-producing substances in concentrations that cause nuisance or adversely affect beneficial uses. The Basin Plan requires the application of the most stringent objective necessary to ensure that surface water and groundwater do not contain chemical constituents, toxic substances, radionuclides, or taste and odor producing substances in concentrations that adversely affect domestic drinking water supply, agricultural supply, or any other beneficial use.

A. Surface Water

1. CWA section 303(a-c), requires states to adopt water quality standards, including criteria where they are necessary to protect beneficial uses. The Regional Water Board adopted water quality criteria as water quality objectives in the Basin Plan. The Basin Plan states that “[t]he numerical and narrative water quality objectives define the least stringent standards that the Regional Board will apply to regional waters in order to protect the beneficial uses.” The Basin Plan includes numeric and narrative water quality objectives for various beneficial uses and water bodies. This Order contains Receiving Surface Water Limitations based on the Basin Plan numerical and narrative water quality objectives for biostimulatory substances, chemical constituents, color, dissolved oxygen, floating material, oil and grease, pH, pesticides, radioactivity, salinity, sediment, settleable material, suspended material, tastes and odors, temperature, toxicity, turbidity, and electrical conductivity.

Numeric Basin Plan objectives for bacteria, dissolved oxygen, pH, temperature, and turbidity are applicable to this discharge and have been incorporated as Receiving Surface Water Limitations. Rational for these numeric receiving surface water limitations are as follows:

- a. ***Biostimulatory Substances.** The Basin Plan includes a water quality objective that “[W]ater shall not contain biostimulatory substances which promote aquatic growths in concentrations that cause nuisance or adversely affect beneficial uses.” Receiving Water Limitations for biostimulatory substances are included in this Order and are based on the Basin Plan objective.
- b. ***Color.** The Basin Plan includes a water quality objective that “[W]ater shall be free of discoloration that causes nuisance or adversely affects beneficial uses.”

- c. ***Chemical Constituents.** The Basin Plan includes a water quality objective that “[W]aters shall not contain chemical constituents in concentrations that adversely affect beneficial uses.” Receiving Water Limitations for chemical constituents are included in this Order and are based on the Basin Plan objective.
- d. ***Floating Material.** The Basin Plan includes a water quality objective that “[W]ater shall not contain floating material in amounts that cause nuisance or adversely affect beneficial uses.” Receiving Water Limitations for floating material are included in this Order and are based on the Basin Plan objective.
- e. ***Oil and Grease.** The Basin Plan includes a water quality objective that “[W]aters shall not contain oils, greases, waxes, or other materials in concentrations that cause nuisance, result in a visible film or coating on the surface of the water or on objects in the water, or otherwise adversely affect beneficial uses.” Receiving Water Limitations for oil and grease are included in this Order and are based on the Basin Plan objective.
- f. ***pH.** The Basin Plan includes water quality objective that “[T]he pH shall not be depressed below 6.5 nor raised above 8.5. Changes in normal ambient pH levels shall not exceed 0.5 in fresh waters with designated COLD or WARM beneficial uses” This Order includes receiving water limitations for both pH range and pH change.

The Basin Plan allows an appropriate averaging period for pH change in the receiving stream. Since there is no technical information available that indicates that aquatic organisms are adversely affected by shifts in pH within the 6.5 to 8.5 range, an averaging period is considered appropriate and a monthly averaging period for determining compliance with the 0.5 receiving water pH limitation is included in this Order.

- g. ***Pesticides.** The Basin Plan includes a water quality objective for pesticides beginning on page III-6.00. Receiving Water Limitations for pesticides are included in this Order and are based on the Basin Plan objective.
- h. ***Radioactivity.** The Basin Plan includes a water quality objective that “[R]adionuclides shall not be present in concentrations that are harmful to human, plant, animal or aquatic life nor that result in the accumulation of radionuclides in the food web to an extent that presents a hazard to human, plant, animal or aquatic life.” The Basin Plan states further that “[A]t a minimum, waters designated for use as domestic or municipal supply (MUN) shall not contain concentrations of radionuclides in excess of the maximum contaminant levels (MCLs) specified in Table 4 (MCL Radioactivity) of Section 64443 of Title 22 of the California Code of Regulations...” Receiving Water Limitations for radioactivity are included in this Order and are based on the Basin Plan objective.

- i. ***Sediment.** The Basin Plan includes a water quality objective that “[T]he suspended sediment load and suspended sediment discharge rate of surface waters shall not be altered in such a manner as to cause nuisance or adversely affect beneficial uses” Receiving Water Limitations for suspended sediments are included in this Order and are based on the Basin Plan objective.
- j. ***Settleable Material.** The Basin Plan includes a water quality objective that “[W]aters shall not contain substances in concentrations that result in the deposition of material that causes nuisance or adversely affects beneficial uses.” Receiving Water Limitations for settleable material are included in this Order and are based on the Basin Plan objective.
- k. ***Suspended Material.** The Basin Plan includes a water quality objective that “[W]aters shall not contain suspended material in concentrations that cause nuisance or adversely affect beneficial uses.” Receiving Water Limitations for suspended material are included in this Order and are based on the Basin Plan objective.
- l. ***Taste and Odors.** The Basin Plan includes a water quality objective that “[W]ater shall not contain taste- or odor-producing substances in concentrations that impart undesirable tastes or odors to domestic or municipal water supplies or to fish flesh or other edible products of aquatic origin, or that cause nuisance, or otherwise adversely affect beneficial uses.” Receiving Water Limitations for taste- or odor-producing substances are included in this Order and are based on the Basin Plan objective.
- m. ***Temperature.** Lake Almanor has the beneficial uses of both COLD and WARM. The Basin Plan includes the objective that “[a]t no time or place shall the temperature of COLD or WARM intrastate waters be increased more than 5°F above natural receiving water temperature.” This Order includes a receiving water limitation based on this objective.
- n. ***Toxicity.** The Basin Plan includes a water quality objective that “[A]ll waters shall be maintained free of toxic substances in concentrations that produce detrimental physiological responses in human, plant, animal, or aquatic life.” Receiving Water Limitations for toxicity are included in this Order and are based on the Basin Plan objective.
- o. ***Turbidity.** The Basin Plan includes a water quality objective that “[I]ncreases in turbidity attributable to controllable water quality factors shall not exceed the following limits:
 - Where natural turbidity is between 0 and 5 Nephelometric Turbidity Units (NTUs), increases shall not exceed 1 NTU.

- *Where natural turbidity is between 5 and 50 NTUs, increases shall not exceed 20 percent.*
- *Where natural turbidity is between 50 and 100 NTUs, increases shall not exceed 10 NTUs.*
- *Where natural turbidity is greater than 100 NTUs, increases shall not exceed 10 percent.”*

A numeric Receiving Surface Water Limitation for turbidity is included in this Order and is based on the Basin Plan objective for turbidity.

B. Groundwater

1. **The** beneficial uses of the underlying ground water are municipal and domestic supply, industrial service supply, industrial process supply, and agricultural supply.
2. Basin Plan water quality objectives include narrative objectives for chemical constituents, tastes and odors, and toxicity of groundwater. The toxicity objective requires that groundwater be maintained free of toxic substances in concentrations that produce detrimental physiological responses in humans, plants, animals, or aquatic life. The chemical constituent objective states groundwater shall not contain chemical constituents in concentrations that adversely affect any beneficial use. The tastes and odors objective prohibits taste- or odor-producing substances in concentrations that cause nuisance or adversely affect beneficial uses. The Basin Plan also establishes numerical water quality objectives for chemical constituents and radioactivity in groundwaters designated as municipal supply. These include, at a minimum, compliance with MCLs in Title 22 of the CCR. The bacteria objective prohibits coliform organisms at or above 2.2 MPN/100 ml. The Basin Plan requires the application of the most stringent objective necessary to ensure that waters do not contain chemical constituents, toxic substances, radionuclides, taste- or odor-producing substances, or bacteria in concentrations that adversely affect municipal or domestic supply, agricultural supply, industrial supply or some other beneficial use.

VI. RATIONALE FOR MONITORING AND REPORTING REQUIREMENTS

Section 122.48 requires that all NPDES permits specify requirements for recording and reporting monitoring results. Water Code sections 13267 and 13383 authorizes the Regional Water Board to require technical and monitoring reports. The Monitoring and Reporting Program (MRP), Attachment E of this Order, establishes monitoring and reporting requirements to implement federal and state requirements. The following provides the rationale for the monitoring and reporting requirements contained in the MRP for this facility.

A. Influent Monitoring

Influent monitoring is required to collect data on the characteristics of the effluent and to assess compliance with effluent limitations

B. Effluent Monitoring

1. Pursuant to the requirements of 40 CFR §122.44(i)(2) effluent monitoring is required for all constituents with effluent limitations. Effluent monitoring is necessary to assess compliance with effluent limitations, assess the effectiveness of the treatment process, and to assess the impacts of the discharge on the receiving stream and groundwater.
2. The SIP states that if “...all reported detection limits of the pollutant in the effluent are greater than or equal to the C [water quality criterion or objective] value, the RWQCB [Regional Water Board] shall establish interim requirements...that require additional monitoring for the pollutant...” All reported detection limits for copper and lead are greater than or equal to corresponding applicable water quality criteria or objectives. Monitoring for these constituents has been included in this Order in accordance with the SIP.

C. Whole Effluent Toxicity Testing Requirements

1. **Acute Toxicity.** Quarterly 96-hour bioassay testing is required to demonstrate compliance with the effluent limitation for acute toxicity. Based on 168 acute toxicity samples collected from January 2005 through August 2008, there were only 4 test failures that were retested as soon as possible. The current permit required semi-annual acute toxicity, however the Discharger has been taking semi-weekly toxicity tests due to some toxicity test failures in Years 2000-2004. Based on recent toxicity test results, the frequency of acute toxicity has been increased from the current permit, but decreased from semi-weekly testing. The frequency of acute toxicity testing will be on a quarterly basis.
2. **Chronic Toxicity.** Annual chronic whole effluent toxicity testing is required in order to demonstrate compliance with the Basin Plan’s narrative toxicity objective and effluent limitations.

D. Receiving Water Monitoring

1. Surface Water

- a. Receiving water monitoring is necessary to assess compliance with receiving water limitations and to assess the impacts of the discharge on the receiving stream.

2. Groundwater – Not Applicable

E. Other Monitoring Requirements

1. Precipitation Monitoring

Precipitation monitoring is required to determine when the effluent contains stormwater.

2. Intake Water Supply Monitoring

Intake water supply monitoring is necessary to assess the background water concentrations in the industrial water supplied to the cogeneration plant.

3. Ash Monitoring

Sludge, Wood waste and ash, removed from the liquid waste shall be monitored to assure that disposal of these material is disposed of in a manner approved by the Executive Office and consistent with consolidated Regulations for Treatment, Storage, Processing, or Disposal of Solid Waste, as set forth in Title 27, California Code of Regulations, division 2, Subdivision 1, Section 20005, et seq.

4. Ash Settling Pond Monitoring

Ash settling pond monitoring is required to determine compliance with freeboard specifications.

5. Aboveground Petroleum Storage Tank Monitoring

Monitoring of the aboveground petroleum storage tanks is required to ensure that the facility is in compliance with the Health and Safety Code, Chapter 6.67, Aboveground Storage of Petroleum, as well as the facilities Spill Prevention Control and Countermeasure Plan.

VII. RATIONALE FOR PROVISIONS

A. Standard Provisions

Standard Provisions, which apply to all NPDES permits in accordance with section 122.41, and additional conditions applicable to specified categories of permits in accordance with section 122.42, are provided in Attachment D. The discharger must comply with all standard provisions and with those additional conditions that are applicable under section 122.42.

Section 122.41(a)(1) and (b) through (n) establish conditions that apply to all State-issued NPDES permits. These conditions must be incorporated into the permits either expressly or by reference. If incorporated by reference, a specific citation to the

regulations must be included in the Order. Section 123.25(a)(12) allows the state to omit or modify conditions to impose more stringent requirements. In accordance with section 123.25, this Order omits federal conditions that address enforcement authority specified in sections 122.41(j)(5) and (k)(2) because the enforcement authority under the Water Code is more stringent. In lieu of these conditions, this Order incorporates by reference Water Code section 13387(e).

B. Special Provisions

1. Reopener Provisions

- a. **Pollution Prevention.** This Order requires the Discharger prepare pollution prevention plans following CWC section 13263.3(d)(3) for **copper and lead**. This reopener provision allows the Regional Water Board to reopen this Order for addition and/or modification of effluent limitations and requirements for these constituents based on a review of the pollution prevention plans.
- b. **Whole Effluent Toxicity.** This Order requires the Discharger to investigate the causes of, and identify corrective actions to reduce or eliminate effluent toxicity through a Toxicity Reduction Evaluation (TRE). This Order may be reopened to include a numeric chronic toxicity limitation, a new acute toxicity limitation, and/or a limitation for a specific toxicant identified in the TRE. Additionally, if a numeric chronic toxicity water quality objective is adopted by the State Water Board, this Order may be reopened to include a numeric chronic toxicity limitation based on that objective.
- c. **Water Effects Ratio (WER) and Metal Translators.** A default WER of 1.0 has been used in this Order for calculating CTR criteria for applicable priority pollutant inorganic constituents. In addition, default dissolved-to-total metal translators have been used to convert water quality objectives from dissolved to total recoverable when developing effluent limitations for copper and lead. If the Discharger performs studies to determine site-specific WERs and/or site-specific dissolved-to-total metal translators, this Order may be reopened to modify the effluent limitations for the applicable inorganic constituents.
- d. **Mixing Zone and Dilution Studies.** Section 1.4 of the SIP established procedures for calculating effluent limitations. Included in the procedures is determination of a dilution credit, which the Regional Water Board may approve or disapprove at its discretion. However, the Discharger has not developed the information needed to determine a dilution credit. Consequently, this Order establishes final effluent limitations based on zero dilution. This Order also has a reopener that allows new effluent limitations to be adopted if a mixing zone and dilution study demonstrates that dilution credits are appropriate.

2. Special Studies and Additional Monitoring Requirements

- a. **Chronic Whole Effluent Toxicity Requirements.** The Basin Plan contains a narrative toxicity objective that states, "*All waters shall be maintained free of toxic*

substances in concentrations that produce detrimental physiological responses in human, plant, animal, or aquatic life.” (Basin Plan at III-8.00.) Based on annual whole effluent chronic toxicity testing performed by the Discharger from January 2005 through July 2008, the discharge has reasonable potential to cause or contribute to an in-stream excursion above of the Basin Plan’s narrative toxicity objective.

This provision requires the Discharger to develop a Toxicity Reduction Evaluation (TRE) Work Plan in accordance with EPA guidance. In addition, the provision provides a numeric toxicity monitoring trigger and requirements for accelerated monitoring, as well as, requirements for TRE initiation if a pattern of toxicity has been demonstrated.

Monitoring Trigger. A numeric toxicity monitoring trigger of > 1 TUc (where TUc = 100/NOEC) is applied in the provision, because this Order does not allow any dilution for the chronic condition. Therefore, a TRE is triggered when the effluent exhibits a pattern of toxicity at 100% effluent.

Accelerated Monitoring. The provision requires accelerated WET testing when a regular WET test result exceeds the monitoring trigger. The purpose of accelerated monitoring is to determine, in an expedient manner, whether there is a pattern of toxicity before requiring the implementation of a TRE. Due to possible seasonality of the toxicity, the accelerated monitoring should be performed in a timely manner, preferably taking no more than 2 to 3 months to complete.

The provision requires accelerated monitoring consisting of four chronic toxicity tests every two weeks using the species that exhibited toxicity. Guidance regarding accelerated monitoring and TRE initiation is provided in the *Technical Support Document for Water Quality-based Toxics Control, EPA/505/2-90-001, March 1991* (TSD). The TSD at page 118 states, “EPA recommends if toxicity is repeatedly or periodically present at levels above effluent limits more than 20 percent of the time, a TRE should be required.” Therefore, four accelerated monitoring tests are required in this provision. If no toxicity is demonstrated in the four accelerated tests, then it demonstrates that toxicity is not present at levels above the monitoring trigger more than 20 percent of the time (only 1 of 5 tests are toxic, including the initial test). However, notwithstanding the accelerated monitoring results, if there is adequate evidence of a pattern of effluent toxicity (i.e. toxicity present exceeding the monitoring trigger more than 20 percent of the time), the Executive Officer may require that the Discharger initiate a TRE.

See the WET Accelerated Monitoring Flow Chart (Figure F-3), below, for further clarification of the accelerated monitoring requirements and for the decision points for determining the need for TRE initiation.

TRE Guidance. The Discharger is required to prepare a TRE Work Plan in accordance with USEPA guidance. Numerous guidance documents are available, as identified below:

- *Toxicity Reduction Evaluation Guidance for Municipal Wastewater Treatment Plants*, (EPA/833B-99/002), August 1999.
- *Generalized Methodology for Conducting Industrial TREs*, (EPA/600/2-88/070), April 1989.
- *Methods for Aquatic Toxicity Identification Evaluations: Phase I Toxicity Characterization Procedures*, Second Edition, EPA 600/6-91/005F, February 1991.
- *Toxicity Identification Evaluation: Characterization of Chronically Toxic Effluents, Phase I*, EPA 600/6-91/005F, May 1992.
- *Methods for Aquatic Toxicity Identification Evaluations: Phase II Toxicity Identification Procedures for Samples Exhibiting acute and Chronic Toxicity*, Second Edition, EPA 600/R-92/080, September 1993.
- *Methods for Aquatic Toxicity Identification Evaluations: Phase III Toxicity Confirmation Procedures for Samples Exhibiting Acute and Chronic Toxicity*, Second Edition, EPA 600/R-92/081, September 1993.
- *Methods for Measuring the Acute Toxicity of Effluents and Receiving Waters to Freshwater and Marine Organisms*, Fifth Edition, EPA-821-R-02-012, October 2002.
- *Short-term Methods for Estimating the Chronic Toxicity of Effluents and Receiving Waters to Freshwater Organisms*, Fourth Edition, EPA-821-R-02-013, October 2002.
- *Technical Support Document for Water Quality-based Toxics Control*, EPA/505/2-90-001, March 1991

Figure F-3
WET Accelerated Monitoring Flow Chart

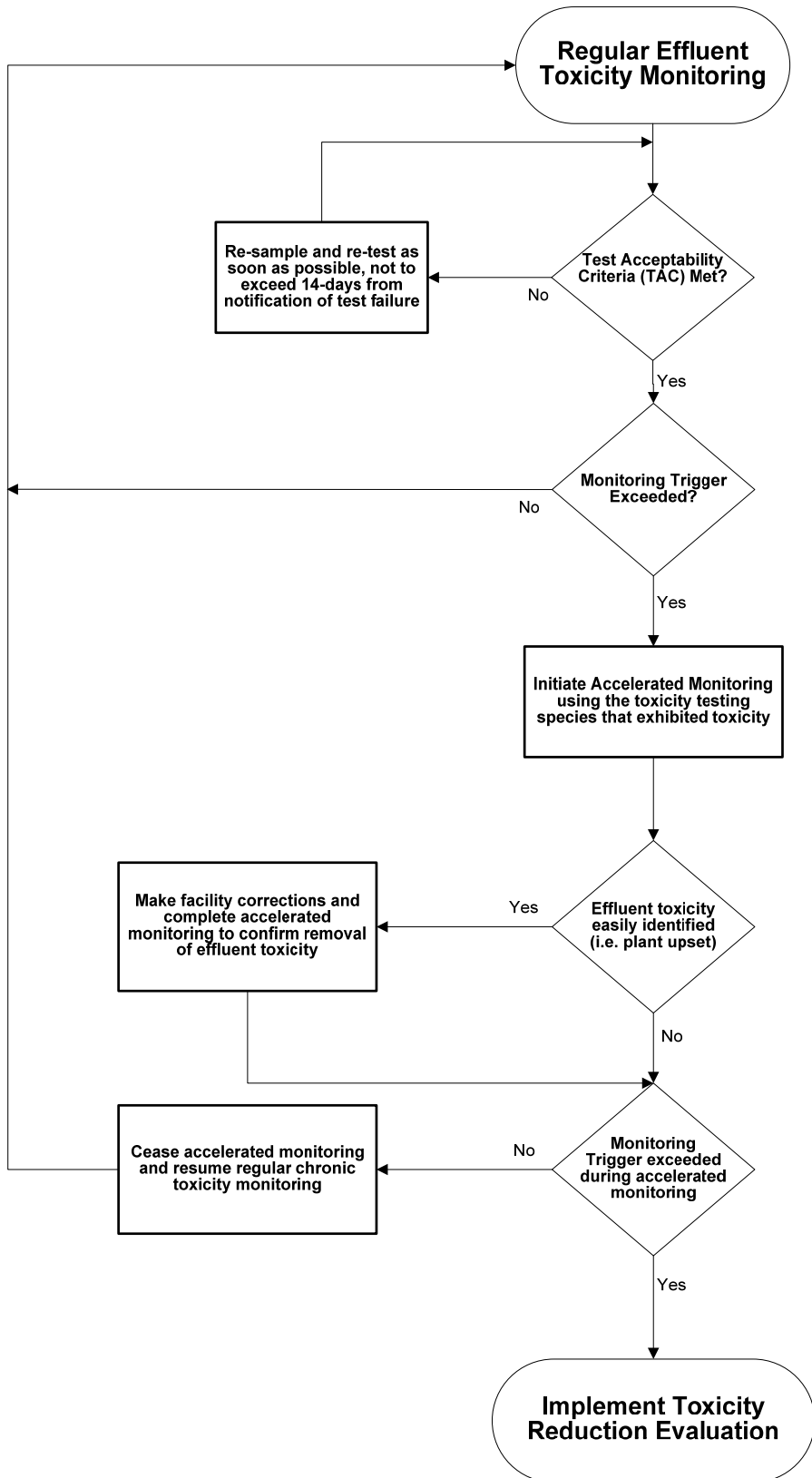

- c. Salinity Evaluation and Minimization Plan.** The Discharger shall prepare a salinity evaluation and minimization plan to address sources of salinity from the Facility. The plan shall be completed and submitted to the Regional Water Board **within 2 years of the effective date of this Order** for the approval by the Executive Officer.

3. Best Management Practices and Pollution Prevention

- a. Pollution Prevention Plan (PPP) for copper and lead.** A PPP for copper and lead is required in this Order per CWC section 13263.3(d)(1)(D) as part of the interim effluent limitation for mercury. The interim effluent limitations for copper and lead limit the mass loading to current levels. The PPP shall be developed in conformance with CWC section 13263.3(d)(3) as outlined in subsection b., below.
- b. CWC section 13263.3(d)(3) Pollution Prevention Plans.** The pollution prevention plans required for copper and lead shall, at minimum, meet the requirements outlined in CWC section 13263.3(d)(3). The minimum requirements for the pollution prevention plans include the following:
- i. An estimate of all of the sources of a pollutant contributing, or potentially contributing, to the loadings of a pollutant in the treatment plant influent.
 - ii. An analysis of the methods that could be used to prevent the discharge of the pollutants into the Facility, including application of local limits to industrial or commercial dischargers regarding pollution prevention techniques, public education and outreach, or other innovative and alternative approaches to reduce discharges of the pollutant to the Facility. The analysis also shall identify sources, or potential sources, not within the ability or authority of the Discharger to control, such as pollutants in the potable water supply, airborne pollutants, pharmaceuticals, or pesticides, and estimate the magnitude of those sources, to the extent feasible.
 - iii. An estimate of load reductions that may be attained through the methods identified in subparagraph ii.
 - iv. A plan for monitoring the results of the pollution prevention program.
 - v. A description of the tasks, cost, and time required to investigate and implement various elements in the pollution prevention plan.
 - vi. A statement of the Discharger's pollution prevention goals and strategies, including priorities for short-term and long-term action, and a description of the Discharger's intended pollution prevention activities for the immediate future.
 - vii. A description of the Discharger's existing pollution prevention programs.

- viii. An analysis, to the extent feasible, of any adverse environmental impacts, including cross-media impacts or substitute chemicals that may result from the implementation of the pollution prevention program.
- ix. An analysis, to the extent feasible, of the costs and benefits that may be incurred to implement the pollution prevention program.

4. Construction, Operation, and Maintenance Specifications

- a. Ponds shall be managed to prevent breeding of mosquitoes. In particular
 - a. An erosion control program should assure that small coves and irregularities are not created around the perimeter of the water surface.
 - b. Weeds shall be minimized.
 - c. Dead algae, vegetation, and debris shall not accumulate on the water surface.
- b. The Discharger shall maintain a minimum of 2 foot of freeboard in the discharge ponds (measured vertically to the lowest point of overflow) **except if lesser freeboard does not threaten the integrity of the pond, no overflow of the pond occurs, and lesser freeboard is due to direct precipitation or storm water runoff occurring as a result of annual precipitation with greater than a 100-year recurrence interval, or a storm event with an intensity greater than a 25-year, 24-hour storm event.**

5. Special Provisions for Municipal Facilities (POTWs Only) – Not Applicable

6. Other Special Provisions

- a. All technical reports required herein that involve planning, investigation, evaluation, or design, or other work requiring interpretation and proper application of engineering or geologic sciences, shall be prepared by or under the direction of persons registered to practice in California pursuant to California Business and Professions Code, Sections 6735, 7835, and 7835.1. To demonstrate compliance with Title 16, CCR, Sections 415 and 3065, all technical reports must contain a statement of the qualifications of the responsible registered professional(s). As required by these laws, completed technical reports must bear the signature(s) and seal(s) of the registered professional(s) in a manner such that all work can be clearly attributed to the professional responsible for the work.
- b. In the event the Discharger does not comply or will be unable to comply for any reason, with any prohibition or limitation contained in this Order, this Order requires the Discharger to notify the Regional Water Board by telephone (916) 464-3291 (or to the Regional Water Board staff engineer assigned to the facility)

within 24 hours of having knowledge of such noncompliance, and shall confirm this notification in writing within five days, unless the Regional Water Board waives confirmation. The written notification shall include the information required by Federal Standard Provision [40 CFR §122.41(l)(6)(i)].

- c. Prior to making any change in the discharge point, place of use, or purpose of use of the storm water, the Discharger must obtain approval of, or clearance from the State Water Resources Control Board (Division of Water Rights).

In the event of any change in control or ownership of land or facilities presently owned or controlled by the Discharger, the Discharger shall notify the succeeding owner or operator of the existence of this Order by letter, a copy of which shall be immediately forwarded to this office.

To assume operation under this Order, the succeeding owner or operator must apply in writing to the Executive Officer requesting transfer of the Order. The request must contain the requesting entity's full legal name, the State of incorporation if a corporation, address and telephone number of the persons responsible for contact with the Regional Water Board and a statement. The statement shall comply with the signatory paragraph of Federal Standard Provision V.B.5 and state that the new owner or operator assumes full responsibility for compliance with this Order. Failure to submit the request shall be considered a discharge without requirements, a violation of the California Water Code. Transfer shall be approved or disapproved in writing by the Executive Officer.

7. Compliance Schedules

The use and location of compliances schedules in the permit depends on the Discharger's ability to comply and the source of the applied water quality criteria.

The Discharger submitted a request for a compliance schedule for copper and lead. This Order establishes a compliance schedule for the new, final, water quality-based effluent limitations for copper and lead and requires full compliance by 17 May 2010.

VIII. PUBLIC PARTICIPATION

The California Regional Water Quality Control Board, Central Valley Region (Regional Water Board) is considering the issuance of waste discharge requirements (WDRs) that will serve as a National Pollutant Discharge Elimination System (NPDES) permit for Collins Pine Company – Chester Sawmill. As a step in the WDR adoption process, the Regional Water Board staff has developed tentative WDRs. The Regional Water Board encourages public participation in the WDR adoption process.

A. Notification of Interested Parties

The Regional Water Board has notified the Discharger and interested agencies and persons of its intent to prescribe waste discharge requirements for the discharge and has provided them with an opportunity to submit their written comments and recommendations. Notification was provided through the physical posting, mailing and internet posting.

B. Written Comments

The staff determinations are tentative. Interested persons are invited to submit written comments concerning these tentative WDRs. Comments must be submitted either in person or by mail to the Executive Office at the Regional Water Board at the address above on the cover page of this Order.

To be fully responded to by staff and considered by the Regional Water Board, written comments should be received at the Regional Water Board offices by Noon on **5 January 2009**.

C. Public Hearing

The Regional Water Board will hold a public hearing on the tentative WDRs during its regular Board meeting on the following date and time and at the following location:

Date: 5 February 2009
Time: 8:00 am
Location: Regional Water Quality Control Board, Central Valley Region
11020 Sun Center Dr., Suite #200
Rancho Cordova, CA 95670

Interested persons are invited to attend. At the public hearing, the Regional Water Board will hear testimony, if any, pertinent to the discharge, WDRs, and permit. Oral testimony will be heard; however, for accuracy of the record, important testimony should be in writing.

Please be aware that dates and venues may change. Our Web address is <http://www.waterboards.ca.gov/centralvalley/> where you can access the current agenda for changes in dates and locations.

D. Waste Discharge Requirements Petitions

Any aggrieved person may petition the State Water Resources Control Board to review the decision of the Regional Water Board regarding the final WDRs. The petition must be submitted within 30 days of the Regional Water Board's action to the following address:

State Water Resources Control Board
Office of Chief Counsel
P.O. Box 100, 1001 I Street
Sacramento, CA 95812-0100

E. Information and Copying

The Report of Waste Discharge (RWD), related documents, tentative effluent limitations and special provisions, comments received, and other information are on file and may be inspected at the address above at any time between 8:30 a.m. and 4:45 p.m., Monday through Friday. Copying of documents may be arranged through the Regional Water Board by calling (530) 224-4845.

F. Register of Interested Persons

Any person interested in being placed on the mailing list for information regarding the WDRs and NPDES permit should contact the Regional Water Board, reference this facility, and provide a name, address, and phone number.

G. Additional Information

Requests for additional information or questions regarding this order should be directed to Greg Cash at (530) 224-3208.