

North Coast Regional Water Quality Control Board

**ORDER No. R1-2020-0024
WDID No. 1A83052OTRI
WASTE DISCHARGE REQUIREMENTS
for
LEWISTON COMMUNITY SERVICES DISTRICT
WASTEWATER TREATMENT FACILITY
TRINITY COUNTY**

The following Discharger is subject to waste discharge requirements (WDRs) as set forth in this Order:

Table 1. Discharger Information

Discharger	Lewiston Community Services District (CSD)
Name of Facility	Lewiston CSD Wastewater Treatment Facility
Facility Address	Lewiston Road at Viola Lane
	Lewiston, CA 96052

The discharge by the Lewiston CSD from the discharge point identified below is subject to waste discharge requirements as set forth in this Order

Table 2. Discharge Location

Discharge Point	Effluent Description	Discharge Point Latitude	Discharge Point Longitude	Receiving Water
001	Treated Municipal Wastewater	N 40° 42' 22"	W 122° 48' 43"	Groundwater

IT IS HEREBY ORDERED, that Order No. 97-11 and No. 83-52 except for enforcement purposes, are rescinded upon notification of startup and the beginning of waste discharge from the new wastewater treatment and disposal system (anticipated to be January 2021), which is the effective date of this Order. In order to meet the provisions contained in division 7 of the Water Code (commencing with section 13000) and regulations adopted thereunder, the Discharger shall comply with the requirements in this Order.

I, Matthias St. John, Executive Officer, do hereby certify that this Order with all attachments is a full, true, and correct copy of an Order adopted by the California Regional Water Quality Control Board, North Coast Region, on **October 15, 2020**.

Matthias St. John, Executive Officer

20_0024_LewistonCSD_WDR

I. FACILITY INFORMATION

The following Discharger is subject to waste discharge requirements as set forth in this Order:

Table 3. Facility Information

Discharger	Lewiston CSD
Name of Facility	Lewiston CSD Wastewater Treatment Facility
Facility Address	Lewiston Road at Viola Lane
	Lewiston, CA 96052
	Trinity County
Facility Contact, Title, and Phone	Mel Deardorff, Board President, 707-778-3502
Mailing Address	P.O. Box 164, Lewiston, CA 96052
Type of Facility	Publicly Owned Treatment Works (POTW)
Facility Design Flow	0.04 million gallons per day (mgd) monthly Average Dry Weather Flow (ADWF); 0.160 mgd Peak Wet Weather Flow (PWWF)

II. FINDINGS

The California Regional Water Quality Control Board, North Coast Region (hereinafter Regional Water Board), finds:

A. Basis and Rationale for Requirements

The Regional Water Board developed the requirements in this Order based on information submitted as part of the Discharger's application for permit renewal, monitoring data submitted during the term of the Discharger's previous Order, and other available information.

B. Background and Facility Description

The community of Lewiston was established in 1957 by the U.S. Bureau of Reclamation as a government work camp for the construction of the Lewiston Dam and the Trinity Dam, a part of the Central Valley Project. Following completion of the dams, the government parcels were sold to residents and other investors. Two major subdivisions were created: Lewiston Park and Lewiston Heights, and various other private parcels, including the Trinity Dam Mobile Home Park (TDMHP). Community water supply and wastewater treatment and disposal for Lewiston Park was provided by the Lewiston Park Mutual Water Company (LPMWC: WDR No. 83-52). Community water supply and wastewater treatment and disposal for Lewiston Heights was provided by the Lewiston Valley Mutual Water Company (LVMWC: WDR No. 97-11). The TDMHP has no community

wastewater service and discharges domestic wastewater to a large septic tank and then to an unlined pond located adjacent to the park. Lewiston CSD proposes to consolidate, replace and upgrade these three facilities.

The Discharger submitted a Report of Waste Discharge (ROWD) on June 1, 2017, which proposed consolidation of the LPMWC, the LVMWC and the TDMHP. Additional information to complete the ROWD was received from PACE Engineering on April 10, 2018, June 1, 2018, June 8, 2018, June 22, 2018, July 11, 2018, July 12, 2018, August 8, 2018, September 4, 2018, September 24, 2018, January 10, 2019, January 14, 2019, January 15, 2019, January 21, 2019, January 29, 2019, February 22, 2019, February 27, 2019, March 13, 2019, March 27, 2019, May 2, 2019, May 13, 2019, May 20, 2019, June 3, 2019, June 17, 2019. The ROWD was deemed complete on June 17, 2019.

The project will include replacement of the collection systems and replacement of the wastewater treatment facilities with an upgraded wastewater treatment facility. Treated effluent will be disposed by leach field beds located adjacent to the Trinity River on land managed by the U.S. Bureau of Reclamation (U.S. BOR). The Facility will serve approximately 253 residential and commercial connections within the community of Lewiston. The design population is 649 people. The Facility has a design average dry weather flow (ADWF) of 0.04 mgd and a design peak wet weather flow (PWWF) of 0.160 mgd.

The project will include wastewater service to private parcels, as well as local, state, and federally owned parcels. The percolation beds by the Trinity River are located on land managed by the U.S. BOR. The emergency retention basin and sludge storage basins are located on land managed by the U.S. BLM. Copies of the Right-of-Way and License agreements for both the U.S. BOR and U.S. BLM are on file and available upon request.

The project to consolidate and upgrade the facilities will include replacing the collection systems for the former LPMWC and TDMHP in their entirety, portions of the LCSD (formerly LVMWC) collection system, and LCSD lateral pipelines made of Orangeburg pipe, a pipe material made of wood pulp and sealed with coal tar and that is long past its useful life, and those that are failing on private property. The existing suspended pipeline over the Trinity River will be replaced. The existing LCSD (formerly LPMWC) wastewater treatment facility will be replaced with an Aero-Mod activated sludge facility. Lift Station 1 and 2 will be decommissioned, and a new lift station (TDBLS) will be constructed to convey all wastewater from the former LVMWC and TDMHP to the new LCSD wastewater treatment facility. The existing LCSD oxidation ponds will be repurposed for use as an emergency effluent retention basin. The former LPMWC percolation beds will be reconstructed into eight leach field beds. The leach field beds are located approximately 75 feet north of the Trinity River.

Aerobically digested sludge will be dried in four drying beds at the LCSD wastewater treatment facility and disposed of at a permitted landfill.

Attachment A provides a map of the general location of the Facility. Attachment B provides a map of the Facility, effluent pipeline and leach fields. Attachment C provides a design Facility layout. Attachment D provides a Facility flow schematic. Attachment E is the Monitoring and Reporting Program.

Legal Authorities

This Order serves as Waste Discharge Requirements (WDRs) for discharges to land issued pursuant to section 13263 of the California Water Code (Water Code).

C. Basin Plan

As required by Water Code section 13263(a), these WDRs are crafted to implement the Water Quality Control Plan for the North Coast Region (Basin Plan), and in so doing, the Regional Water Board has taken into consideration the beneficial uses to be protected, the water quality objectives (both numeric and narrative) reasonably required for that purpose, other (including previous) waste discharges, the need to prevent nuisance, and the provisions of Water Code section 13241. The Basin Plan contains implementation plans and policies for protecting waters of the basin. The Basin Plan implements State Water Resources Control Board (State Water Board) Resolution No. 88-63, which established state policy that all waters, with certain exceptions, should be considered suitable or potentially suitable for municipal or domestic supply.

Thus, beneficial uses applicable to area groundwater within the Douglas City Hydrologic Subarea of the Middle Trinity River Hydrologic Area to be protected are as follows: municipal and domestic supply (MUN), agricultural water supply (AGR), industrial service supply (IND), industrial process supply (PRO), aquaculture (AQUA), and Native American culture (CUL).

The beneficial uses applicable to surface waters in the Douglas City Hydrologic Subarea within the Middle Trinity River Hydrologic Area are as follows: municipal and domestic supply (MUN), agricultural water supply (AGR), industrial service supply (IND), industrial process supply (PRO), groundwater recharge (GWR), freshwater replenishment (FRSH), navigation (NAV), hydropower generation (POW), water contact recreation (REC-1), non-contact water recreation (REC-2), commercial and sport fishing (COMM), cold freshwater habitat (COLD), wildlife habitat (WILD), rare, threatened, or endangered species (RARE), migration of aquatic organisms (MIGR), spawning, reproduction, and/or early development (SPWN), and aquaculture (AQUA).

D. Water Code

The Water Code establishes the authority for the Regional Water Board to establish water quality objectives, impose discharge prohibitions, and prescribe waste discharge and reclamation requirements. Water Code section 13241 requires each regional board to “establish such water quality objectives in water quality control plans as in its judgment will ensure the reasonable protection of beneficial uses and the prevention of nuisance [...]” The control of waste is established through effluent limitations and other requirements in Waste Discharge Requirement permits. Water Code section 13243 provides that “A regional board, in a water quality control plan or in waste discharge requirements, may specify certain conditions or areas where the discharge of waste, or certain types of waste, will not be permitted.”

It is the Regional Water Board’s intent that this Order shall ensure attainment of water quality standards, applicable water quality objectives, and protection of beneficial uses of receiving waters. This Order therefore requires the Discharger to comply with all prohibitions, discharge specifications, receiving water limitations, standard provisions, and monitoring and reporting requirements. The Order further prohibits discharges from causing violations of water quality objectives or causing conditions to occur that create a condition of nuisance or water quality impairment in receiving waters as a result of the discharge.

E. Title 27 Exemption.

The wastewater treatment, storage, and disposal activities described in this Order are exempt from the requirements of Consolidated Regulations for Treatment, Storage, Processing, or Disposal of Solid Waste in California Code of Regulations, title 27, division 2, Subdivision 1, section 20005, et seq. The activities are exempt from the requirements of title 27 so long as the activity meets, and continues to meet, all preconditions listed below. (Cal. Code Regs., tit. 27, § 20090.)

1. Sewage—Discharges of domestic sewage or treated effluent which are regulated by WDRs issued pursuant to California Code of Regulations, title 23, division 3, chapter 9, or for which WDRs have been waived, and which are consistent with applicable water quality objectives, and treatment or storage facilities associated with municipal wastewater treatment plants, provided that residual sludge or solid waste from wastewater treatment facilities shall be discharged only in accordance with the applicable State Water Board promulgated provisions of this division. (Cal. Code Regs., tit. 27, § 20090(a).)
2. Wastewater—Discharges of wastewater to land, including but not limited to evaporation ponds, percolation ponds, or subsurface leach fields if the following conditions are met:

- a. the applicable Regional Water Board has issued WDRs, reclamation requirements, or waived such issuance;
 - b. the discharge is in compliance with the applicable water quality control plan; and
 - c. the wastewater does not need to be managed according to, California Code of Regulations, title 22, division 4.5, chapter 11, as a hazardous waste. (Cal. Code Regs., tit. 27, § 20090(b).
3. Underground Injection—Discharges of waste to wells by injection pursuant to the Underground Injection Control Program established by the U.S. Environmental Protection Agency under the Safe Drinking Water Act, 42 US Code section 300(h), see Code of Federal Regulations title 40, Parts 144 to 146. (Cal. Code Regs., tit. 27, § 20090(c).)
 4. Fully Enclosed Units—Waste treatment in fully enclosed facilities, such as tanks, or in concrete lined facilities of limited areal extent, such as oil water separators designed, constructed, and operated according to American Petroleum Institute specifications. (Cal. Code Regs., tit. 27, § 20090(i).)

F. Antidegradation Policy

State Water Board Resolution 68-16, the Statement of Policy with Respect to Maintaining High Quality Waters of California (hereafter the Antidegradation Policy) requires the disposal of waste be regulated to achieve the highest water quality consistent with the maximum benefit to the people of the state. The Antidegradation Policy applies when a discharge may degrade high quality waters¹ and requires the following:

1. Higher quality water will be maintained until it has been demonstrated to the state that any change will be consistent with the maximum benefit to the people of the state, will not unreasonably affect present and anticipated beneficial use of the water, and will not result in water quality less than prescribed in the policies.

Any activity that produces a waste and discharges to existing high quality waters will be required to meet Waste Discharge Requirements that will result in the best practicable treatment or control of the discharge necessary to assure pollution or

¹ The Board interprets “high quality waters” as the best water quality that has existed since the Policy was adopted in 1968 after considering any subsequently authorized degradation that has been allowed in compliance with the Policy.

nuisance will not occur, and the highest water quality consistent with the maximum benefit to the people of the state will be maintained.

Limited degradation of groundwater by some waste constituents associated with domestic wastewater effluent, after effective source control, treatment, and control measures are implemented, is consistent with the maximum benefit to the people of the state. The technology, energy, water recycling, and waste management advantages of centralized wastewater treatment systems far exceed any benefits derived from reliance on numerous, concentrated individual wastewater systems, and the cumulative impact on water quality will be substantially less. The economic prosperity of a small disadvantaged community and associated industry is of maximum benefit to the people of the state and provides sufficient justification for allowing the limited groundwater degradation that may occur pursuant to this Order provided the terms of the Basin Plan, and other applicable State Water Board and Regional Water Board policies are consistently met.

This Order is consistent with Resolution No. 68-16 because implementation of the Order will result in the application of management measures to treat the discharge of waste that constitutes the best practicable treatment or control of the discharge. This Order contains discharge prohibitions, effluent limitations, receiving water limitations, monitoring requirements, and a requirement for the Discharger to complete a study to assess whether the discharges are affecting groundwater quality. These provisions will ensure that the discharge does not result in exceedances of water quality standards and is protective of beneficial uses of groundwater and surface waters within the Middle Trinity River Hydrologic Area.

This Order does not authorize an increased volume or concentration of waste, or a decreased level of treatment. This Order includes requirements to develop and implement a source control program to prevent toxic pollutants from passing through or interfering with the operation of the wastewater treatment system.

This Order also includes new monitoring requirements to assess the concentration of nitrogen in the treated effluent to ensure that the best practicable treatment and control measures are effective and protective of beneficial uses of groundwater and surface waters.

G. Human Right to Water

It is the policy of the State of California that every human being has the right to safe, clean, affordable, and accessible water adequate for human consumption, cooking, and sanitary purposes (Water Code §106.3, subd. (a)). The Safe Drinking Water Act provides that all Californians have a right to pure and safe drinking water (Health & Safety Code § 116270, subd. (a)). This Order promotes that policy by requiring the Discharger to handle and dispose of waste in a manner

that will protect water quality objectives, including those that protect drinking water supplies.

H. Endangered Species Act

This Order does not authorize any act that results in the taking of a threatened or endangered species or any act that is now prohibited, or becomes prohibited in the future, under either the California Endangered Species Act (Fish and Game Code sections 2050 to 2097) or the Federal Endangered Species Act (16 U.S.C.A sections 1531 to 1544). The Discharger is responsible for meeting all requirements of the applicable Endangered Species Act.

I. Monitoring and Reporting

Water Code section 13267 authorizes the Regional Water Board to require technical and monitoring reports. The Monitoring and Reporting Program establishes monitoring and reporting requirements to implement State requirements. The Monitoring and Reporting Program is necessary to determine compliance with the conditions of this Order and to determine the discharges impacts, if any, on groundwater. As such, the burden, including costs, of this monitoring bears a reasonable relationship to the need for that information and the benefits to be obtained from that information. This Monitoring and Reporting Program is provided in Attachment E. The Executive Officer of the Regional Water Board is delegated the authority to modify the Monitoring and Reporting Program, as determined appropriate to protect water quality.

J. California Environmental Quality Act (CEQA)

The discharges covered under this permit are exempt pursuant to California Code of Regulations, title 14, section 15301 (ongoing or existing projects). The Facility is an existing wastewater treatment facility with no expansion of use or wastewater flow beyond existing use or design capacity.

K. Notification of Interested Parties

The Regional Water Board has notified the Discharger and interested agencies and persons of its intent to prescribe Waste Discharge Requirements for the discharge and has provided them with an opportunity to submit their written comments and recommendations.

L. Consideration of Public Comment

The Regional Water Board provided a 30-day written comment period and in a public meeting, heard and considered all comments pertaining to the discharge.

M. Petition of Action

Any person aggrieved by this action of the Regional Water Board may petition the State Water Board to review the action in accordance with Water Code section 13320 and California Code of Regulations, title 23, sections 2050 and following. The State Water Board must receive the petition by 5:00 p.m., 30 days after the date of this Order, except that if the thirtieth day following the date of this Order falls on a Saturday, Sunday, or state holiday, the petition must be received by the State Water Board by 5:00 p.m. on the next business day. Copies of the law and regulations applicable to filing petitions may be found on the Internet at the North Coast Regional Water Quality Control Board [Website](https://www.waterboards.ca.gov/public_notices/petitions/water_quality/) for notices or will be provided upon request.
(https://www.waterboards.ca.gov/public_notices/petitions/water_quality/)

III. DISCHARGE PROHIBITIONS

- A.** The discharge of waste to the Trinity River and its tributaries is prohibited.
- B.** The discharge of any waste not disclosed by the Discharger or not within the reasonable contemplation of the Regional Water Board is prohibited.
- C.** The presence of surfacing effluent from leach field areas is prohibited.
- D.** Creation of pollution, contamination, or nuisance as defined by section 13050 of the Water Code is prohibited.
- E.** The discharge of untreated or partially treated waste (receiving a lower level of treatment than described in Finding II.B) from anywhere within the collection, treatment, or disposal system is prohibited.
- F.** Any sanitary sewer overflow (SSO) that results in a discharge of untreated or partially treated wastewater to (a) waters of the state or (b) land that creates pollution, contamination, or nuisance as defined in Water Code section 13050 is prohibited.
- G.** The discharge of waste to land that is not owned by or under agreement to use by the Discharger is prohibited.
- H.** The discharge of waste at any point not described in Table 2 or authorized by a permit issued by the State Water Board or Regional Water Board is prohibited.
- I.** The average monthly dry weather flow of waste through the Facility shall not exceed 0.04 mgd. Compliance with this prohibition shall be determined as defined in section IX.B of this Order.

- J. Discharges of waste that violate any narrative or numerical water quality objective that are not authorized by waste discharge requirements or other order or action by the Regional or State Water Board are prohibited.
- K. The discharge of septage or other bulk, high-strength wastes into the Facility or the sanitary sewer system is prohibited.

IV. EFFLUENT LIMITATIONS

- A. The Discharger shall maintain compliance with the following effluent limitations for the discharge of treated wastewater to the leach field beds, with compliance measured at Monitoring Location EFF-002 as described in the Monitoring and Reporting Program.

Table 4. Effluent Limitations

Parameter	Units	Average Monthly Effluent Limitation	Maximum Daily Effluent Limitation	Instantaneous Minimum Effluent Limitation	Instantaneous Maximum Effluent Limitation
Biochemical Oxygen Demand (5-day @ 20°C)	mg/L	10	20	--	--
Total Suspended Solids	mg/L	10	20	--	--
Settleable Solids	ml/L	0.1	0.2	--	--
pH	Standard units	--	--	6.5	8.5
Total Coliform Organisms	MPN/100 mL	23 ²	230	--	--
Nitrogen, Total (as N)	mg/L	10	--		

² Median

V. DISCHARGE SPECIFICATIONS

A. Objectionable Odor

The Discharger shall prevent objectionable odors originating at the Facility from being perceivable beyond the limits of the wastewater treatment and disposal areas.

B. Public Contact

The Discharger shall preclude or control public contact with wastewater through such means as fences and signs, or other applicable alternatives.

C. Vector Control

The Discharger shall manage the Facility and effluent disposal area to prevent the breeding of mosquitos.

VI. SOLIDS HANDLING REQUIREMENTS

A. Sludge, as used in this Order, means the solid, semisolid, and liquid residues removed during primary or secondary wastewater treatment processes.

B. All collected sludges and other solid waste removed from liquid wastes shall be removed from septic tanks, lift stations, headworks, Imhoff tank, clarification, filtration and recirculation as needed to ensure optimal plant operation.

C. All collected sludges and other solid waste removed from liquid wastes shall be disposed of at a legal point of disposal, in accordance with applicable federal and State regulations.

D. The use and disposal of biosolids shall comply with all of the land application and disposal requirements in 40 Code of Federal Regulations (CFR) Part 503, which are enforceable by the U.S. EPA, not the Regional Water Board. If during the life of this Order, the state accepts primacy for implementation of 40 CFR Part 503, the Regional Water Board may also initiate enforcement where appropriate.

E. Sludge or biosolids that are disposed of in a municipal solid waste landfill or used as daily landfill cover shall meet the applicable requirements of 40 CFR Part 258. In the annual self-monitoring report, the Discharger shall report the amount of sludge placed in a landfill and the landfill(s) which received the sludge or biosolids.

F. The Discharger shall prevent and minimize any sludge use or disposal in violation of this Order that may adversely affect human health or the environment.

- G.** Solids and sludge storage shall not create a nuisance, such as objectionable odors or flies, and shall not result in groundwater contamination.
- H.** Solids and sludge storage sites shall have facilities adequate to divert surface water runoff from adjacent areas, to protect the boundaries of the site from erosion, and to prevent drainage from the storage site. Adequate protection is defined as protection from at least a 100-year storm with a 100-year recurrence interval and 24-hour duration.
- I.** The storage of sludge and solids shall not cause waste material to be in a position where it is, or can be, conveyed from the storage site and deposited in waters of the state.

VII. RECEIVING WATER LIMITATIONS

A. Groundwater Limitations

- 1.** The collection, treatment, storage, and disposal of wastewater shall not cause or contribute to degradation of groundwater quality unless a technical evaluation is performed that demonstrates that any degradation that could reasonably be expected to occur, after implementation of all regulatory requirements (e.g., Basin Plan) and reasonable best management practices, will not violate groundwater quality objectives or cause impacts to beneficial uses of groundwater.
- 2.** The collection, treatment, storage and disposal of the treated wastewater shall not cause or contribute to levels of chemical constituents in groundwater that exceed the primary and secondary maximum contaminant levels specified in California Code of Regulations, title 22, Table 64431-A, Table 64444-A, Table 64449-A, and Table 64449-B. (Cal. Code Regs., tit. 22, § 64444 and § 64449.)
- 3.** The collection, treatment, storage and disposal of the treated wastewater shall not cause or contribute to levels of radionuclides in groundwater in excess of the limits specified in California Code of Regulations, title 22, Table 64442 and Table 64443. (Cal. Code Regs., tit. 22, § 64442, and § 64443.)
- 4.** The collection, treatment, storage, and disposal of wastewater shall not cause groundwater to contain taste- or odor-producing substances in concentrations that cause nuisance or adversely affect beneficial uses.
- 5.** The collection, treatment, storage and disposal of the treated wastewater shall not cause the median concentration of coliform organisms over any 7-day period to exceed 1.1 MPN per 100 milliliters or 1 colony per 100 milliliters

in groundwater used or potentially used for domestic and municipal supply (MUN).

6. The collection, treatment, storage and disposal of wastewater shall not cause groundwater to contain toxic substances in concentrations that are toxic to, or that produce detrimental physiological responses in humans, or that adversely affects beneficial uses. This limitation applies regardless of whether the toxicity is caused by a single substance or the synergistic effect of multiple substances.

VIII. GENERAL PROVISIONS

Failure to comply with provisions or requirements of this Order, may subject the Discharger to administrative or civil liabilities, criminal penalties, and/or other enforcement remedies. Additionally, certain violations may subject the Discharger to civil or criminal enforcement from appropriate local, state, or federal law enforcement entities. The Discharger shall comply with the following provisions:

A. Availability

A copy of this Order and the associated Monitoring and Reporting Program shall be maintained at the Facility and be available at all times to operating personnel.

B. Enforcement

The Discharger shall operate and maintain the Facility as described in this Order. Violation of any requirements contained in this Order subject the Discharger to enforcement action, including administrative civil liability or civil liability, under the Water Code.

C. Severability

Provisions of these waste discharge requirements are severable. If any provision of these requirements is found invalid, the remainder of these requirements shall not be affected.

D. Sanitary Sewer Overflows

On May 2, 2006, the State Water Board adopted State Water Board Order No. 2006-0003-DWQ, Statewide General WDRs for Sanitary Sewer Systems. Order No. 2006-0003-DWQ requires that all public agencies that currently own or operate sanitary sewer systems apply for coverage under the General WDRs by November 2, 2006. On September 9, 2013, the State Water Board adopted Order No. WQ-2013-0058-EXEC amending Monitoring and Reporting Program for Statewide General Waste Discharge Requirements for Sanitary Sewer Systems.

The Discharger has coverage under, and is separately subject to the requirements of Order Nos. 2006-0003-DWQ and WQ-2013-0058-EXEC and any future revisions thereto for operation of its wastewater collection system.

E. Operation and Maintenance

The Discharger shall at all times properly operate and maintain all facilities and systems of collection, treatment and control (and related appurtenances) that are installed or used by the Discharger to achieve compliance with this Order. Proper operation and maintenance includes adequate laboratory control and appropriate quality assurance procedures. This provision requires the operation of backup or auxiliary facilities or similar systems that are installed by a Discharger only when necessary to achieve compliance with the conditions of this Order.

The Discharger shall maintain an updated Operation and Maintenance Manual (O&M Manual) for the operational components of the Facility. The Discharger shall update the O&M Manual, as necessary, to conform to changes in operation and maintenance of the Facility. The Discharger shall operate and maintain the Facility in accordance with the most recently updated O&M Manual. The O&M Manual shall be readily available to operating personnel on-site and for review by state inspectors.

The Discharger shall provide notification upon beginning of operation of the new Facility and commencement of discharge from the new Facility.

F. Source Control Provisions

The Discharger shall perform source control functions and provide a summary of source control activities conducted in the Discharger's Annual Report (due March 1st of each year). Source control functions and requirements shall include the following:

1. Implement the necessary legal authorities to monitor and enforce source control standards, restrict discharges of toxic materials to the collection system and inspect facilities connected to the system.
2. If waste haulers are allowed to discharge to the Facility, establish a waste hauler permit system, to be reviewed by the Executive Officer, to regulate waste haulers discharging to the collection system or Facility.
3. Perform public outreach to educate industrial, commercial, and residential users about the importance of preventing discharges of industrial and toxic wastes to the collection system or Facility.

4. Perform ongoing inspections and monitoring, as necessary, to ensure adequate source control.

G. Change in Discharge

The Discharger shall promptly report to the Regional Water Board any material change in the character, location, or volume of the discharge.

H. Change in Control or Ownership

In the event of any change in control or ownership of land or waste discharge facilities presently owned or controlled by the Discharger, the Discharger shall notify the Regional Water Board of such changes in writing, and shall also notify the succeeding owner or operator of the existence of this Order and current compliance status in writing.

The succeeding owner or operator, in order to obtain authorization for discharges regulated by this Order, must apply in writing to the Regional Water Board Executive Officer, requesting transfer of the Order. This request must include complete identification of the new owner or operator, the reasons for the change, and effective date of the change. Discharges conducted without submittal of this request will be considered discharges without waste discharge requirements, which are violations of the Water Code.

I. Vested Rights

This Order does not convey any property rights of any sort or any exclusive privileges. The requirements prescribed herein do not authorize the commission of any act causing injury to persons or property, nor protect the Discharger from liability under federal, state, or local laws, nor create a vested right for the Discharger to continue the waste discharge.

J. Monitoring and Reporting

The Discharger shall comply with the Monitoring and Reporting Program (MRP) and any modifications to these documents as specified by the Regional Water Board Executive Officer. Chemical, bacteriological, and bioassay analyses shall be conducted at a laboratory certified for such analyses by the State of California Environmental Laboratory Accreditation Program. The Discharger shall comply with the MRP in Attachment E of this Order and any future revisions thereto.

K. Records Retention

The Discharger shall maintain records of all monitoring information, including calibration and maintenance records and all strip chart recordings for continuous monitoring instrumentation, copies of all reports required by this Order, and

records of all data used to complete the application for this Order, for a period of at least three (3) years from the date of the sample, measurement, report or application. This period may be extended upon notification of extension by the Regional Water Board Executive Officer.

L. Signatory Requirements

All reports shall be signed by persons identified below:

1. For a corporation: by a principal executive officer of at least the level of senior vice-president.
2. For a partnership or sole proprietorship: by a general partner or the proprietor.
3. For a municipality, state, federal or other public agency: by either a principal executive officer or ranking elected or appointed official.
4. A duly authorized representative of a person designated in L1, L2 or L3 of this requirement if;
 - a. the authorization is made in writing by a person described in L1, L2 or L3 of this requirement;
 - b. the authorization specifies either an individual or a position having responsibility for the overall operation of the regulated facility or activity, such as the position of plant manager, operator of a waste management unit, superintendent, or position of equivalent responsibility. (A duly authorized representative may thus be either a named individual or any individual occupying a named position);
 - c. the written authorization is submitted to the Regional Water Board prior to or together with any reports, information, or applications signed by the authorized representative.

Any person signing a document under paragraph (a) or (b) of this provision shall make the following certification:

"I certify under penalty of law that this document and all attachments were prepared under my direction or supervision in accordance with a system designed to assure that qualified personnel properly gather and evaluate the information submitted. Based on my inquiry of the person or persons who manage the system, or those persons directly responsible for gathering the information, the information submitted, is, to the best of my knowledge and belief, true, accurate, and complete. I am aware that there are significant penalties for submitting false information, including the possibility of fine and imprisonment for knowing violations."

M. Inspections

The Discharger shall permit authorized staff of the Regional Water Board the following:

1. Entrance to the premises in which treatment, collection or management of waste occurs, where an effluent source is located or in which any records required by this Order are kept;
2. Access to inspect and copy any monitoring equipment or records required for compliance with terms and conditions of this Order; and
3. Access to sample any discharge or monitoring location associated with the Facility.

N. Noncompliance

In the event the Discharger is unable to comply with any of the conditions of this Order due to breakdown of waste treatment equipment, accidents caused by human error or negligence, or other causes such as acts of nature, the Discharger shall notify Regional Water Board staff by telephone as soon as it or its agents have knowledge of the incident and confirm this notification in writing within five (5) business days of the telephone notification. The written notification shall include pertinent information explaining reasons for the noncompliance and shall indicate the steps taken to correct the problem and the dates thereof, and the steps being taken to prevent the problem from recurring.

O. Revision of Requirements

The Regional Water Board will review this Order periodically and may revise requirements when necessary.

P. Operator Certification

Supervisors and operators of wastewater treatment plants shall possess a certificate of appropriate grade in accordance with title 23, California Code of Regulations, section 3680. The State Water Board may accept experience in lieu of qualification training. In lieu of a properly certified wastewater treatment plant operator, the State Water Board may approve use of a water treatment plant operator of appropriate grade certified by the State Water Board Division of Drinking Water where water reclamation is involved.

Q. Adequate Capacity

If the Discharger's wastewater treatment plant will reach capacity within 4 years, the Discharger shall notify the Regional Water Board. A copy of such notification

shall be sent to appropriate local elected officials, local permitting agencies, and the press. Factors to be evaluated in assessing reserve capacity shall include, at a minimum, (1) comparison of the wet weather design flow with the highest daily flow, and (2) comparison of the average dry weather design flow with the lowest 30-day flow. The Discharger shall demonstrate that adequate steps are being taken to address the capacity problem. The Discharger shall submit a technical report to the Regional Water Board showing how flow volumes will be prevented from exceeding capacity, or how capacity will be increased, within 120 days after providing notification to the Regional Water Board, or within 120 days after receipt of Regional Water Board notification, that the Facility will reach capacity within 4 years. The time for filing the required technical report may be extended by the Regional Water Board. An extension of 30 days may be granted by the Executive Officer, and longer extensions may be granted by the Regional Water Board itself (title 23, Cal. Code of Regs., section 2232).

R. Special Study to Evaluate the Potential Impact to Surface Water and Groundwater

The Discharger shall conduct an evaluation to confirm that the discharge of treated municipal wastewater from the Facility to the leach field beds complies with the groundwater limitations set forth in section VII.A. of this Order, nor threaten the beneficial uses of the Trinity River. At a minimum, the evaluation must include preparation and submission of a scope of work that describes the proposed monitoring and investigative work to be undertaken, a final work plan that includes work tasks and milestones to complete the evaluation, and a final report that presents the results and conclusion of the evaluation. In the event that the final report concludes that the percolation bed discharge is not attaining groundwater limitations, or threatens the beneficial uses of the Trinity River, the final report shall include a work plan with a proposed compliance schedule to bring the discharge into compliance as soon as practicable.

The preliminary scope of work shall be submitted to the Regional Water Board Executive Officer for approval **within 24 months after Order adoption**. The final work plan shall be submitted for approval by the Regional Water Board Executive Officer **within 6 months after approval of the preliminary scope of work**.

S. Disaster Preparedness Assessment Report and Action Plan

Natural disasters, extreme weather events, sea level rise, and shifting precipitation patterns, some of which are projected to intensify due to climate change, have significant implications for wastewater treatment and operations. Some natural disasters are expected to become more frequent and extreme according to the current science on climate change. In order to ensure that Facility operations are not disrupted, compliance with conditions of this Order are achieved, and receiving waters are not adversely impacted by permitted and unpermitted discharges, the

Discharger shall submit a Disaster Preparedness Assessment Report and Action Plan to the Regional Water Board by **December 1, 2022**, for Executive Officer review and approval.

The Discharger shall: (1) conduct an assessment of the wastewater treatment facility, operations, collection, and discharge systems to determine areas of short and long-term vulnerabilities related to natural disasters and extreme weather, and other conditions projected by climate change science, if applicable; the assessment shall consider, as applicable, impacts to plant operations due to changing influent and receiving water quality, rising sea level, storm surges, fires, floods, earthquakes, tsunamis, back-to-back severe storms, and other extreme conditions that pose a risk to plant operations and water quality; (2) identify control measures needed to protect, improve, and maintain wastewater infrastructure, waste discharge compliance, and receiving water quality in the event of a natural disaster or, if applicable, under conditions resulting from climate change; (3) develop a schedule to implement necessary control measures. Control measures shall include, but are not limited to, emergency procedures, contingency plans, alarm/notification systems, training, backup power and equipment, and the need for planned mitigations to ameliorate potential risks associated with extreme weather events and changing conditions resulting from climate change; and (4) implement the necessary control measures per the approved schedule of implementation.

T. Startup Operations Plan

The Discharger may, at least 30 days in advance of operating the upgraded Facility, submit a startup operations plan for Executive Officer approval. The plan shall describe the actions the Discharger will take during a specific period that requires adjusting and testing new treatment plant units, including steps to prevent violations of this Order. If the Discharger pursues this option, the startup operations plan will define the shortest reasonable time period required for the adjusting and testing to meet effluent limitations, which is not to exceed 90 days for biological treatment units and 30 days for any other treatment unit.

IX. COMPLIANCE DETERMINATION

Compliance with this Order will be determined as specified below.

A. Multiple Sample Data

When determining compliance with an average effluent limitation, and more than one sample result is available, the Discharger shall compute the arithmetic mean unless the data set contains one or more reported determinations of "Detected, but Not Quantified" (DNQ) or "Not Detected" (ND). In those cases, the Discharger

shall compute the median in place of the arithmetic mean in accordance with the following procedure:

1. The arithmetic mean of all samples collected in a calendar month, calculated as the sum of all samples in a calendar month divided by the number of samples. If only one sample is collected in a calendar month, that sample result will constitute the monthly average and daily maximum results for the purpose of determining compliance with effluent limitations.
2. If the average of daily discharges over a calendar month exceeds the AMEL for a given parameter, this will represent a single violation, though the Discharger will be considered out of compliance for each day of that month for that parameter (e.g., resulting in 31 days of non-compliance in a 31-day month). If only a single sample is taken during the calendar month and the analytical results for that sample exceeds the AMEL, the Discharger will be considered out of compliance for that calendar month. The Discharger will only be considered out of compliance for days when the discharge occurs. For any one calendar month during which no sample (daily discharge) is taken, no compliance determination can be made for that calendar month.

B. Monthly Average Dry Weather Flow

Compliance with the monthly average dry weather flow prohibition in section III.I of this Order will be determined once each month by evaluating all flow data collected in the corresponding calendar month. The flow through the Facility, measured daily and averaged monthly, must be 0.04 mgd or less, during dry weather conditions, for the month in any calendar year with the lowest average monthly flow.

C. Average Monthly Effluent Limitation (AMEL)

1. The arithmetic mean of all samples collected in a calendar month, calculated as the sum of all samples in a calendar month divided by the number of samples. If only one sample is collected in a calendar month, that sample result will constitute the monthly average and daily maximum results for the purpose of determining compliance with effluent limitations.
2. If the average of daily discharges over a calendar month exceeds the AMEL for a given parameter, this will represent a single violation, though the Discharger will be considered out of compliance for each day of that month for that parameter (e.g., resulting in 31 days of non-compliance in a 31-day month). If only a single sample is taken during the calendar month and the analytical results for that sample exceeds the AMEL, the Discharger will be considered out of compliance for that calendar month. The Discharger will only be considered out of compliance for days when the discharge occurs.

For any one calendar month during which no sample (daily discharge) is taken, no compliance determination can be made for that calendar month.

D. Maximum Daily Effluent Limitation (MDEL)

If a discharge (or when applicable, the median determined by subsection A, above, for multiple sample data of a daily discharge) exceeds the MDEL for a given parameter, the Discharger will be considered out of compliance for that parameter for that one day only within the reporting period. For any one day during which no sample is taken, no compliance determination can be made for that day.

E. Instantaneous Minimum Effluent Limitations

If the analytical result of a single grab sample is lower than the instantaneous minimum effluent limitation for a parameter, the Discharger will be considered out of compliance for that parameter for that single sample. Non-compliance for each sample will be considered separately (e.g., the results of two grab samples taken within a calendar day that both are lower than the instantaneous minimum effluent limitation would result in two instances of non-compliance with the instantaneous minimum effluent limitation).

F. Instantaneous Maximum Effluent Limitations

If the analytical result of a single grab sample is higher than the instantaneous maximum effluent limitation for a parameter, the Discharger will be considered out of compliance for that parameter for that single sample. Non-compliance for each sample will be considered separately (e.g., the results of two grab samples taken within a calendar day that both exceed the instantaneous maximum effluent limitation would result in two instances of non-compliance with the instantaneous maximum effluent limitation).

G. Bacteriological Limitations

The median is the central tendency concentration of the pollutant. The data set shall be ranked from low to high, ranking the ND concentrations lowest, DNQ determinations next, followed by quantified values. The order of the individual ND and DNQ determinations is not important. The median value is determined based on the number of data points in the data set. If the data set has an odd number of data points, then the median is the middle value. If the data set has an even number of data points, the median is the average of the two middle values, unless one or both points are ND or DNQ, in which case the median value shall be the lower of the two middle data points. DNQ is lower than a detected value, and ND is lower than DNQ.

ATTACHMENT A - FACILITY LOCATION MAP

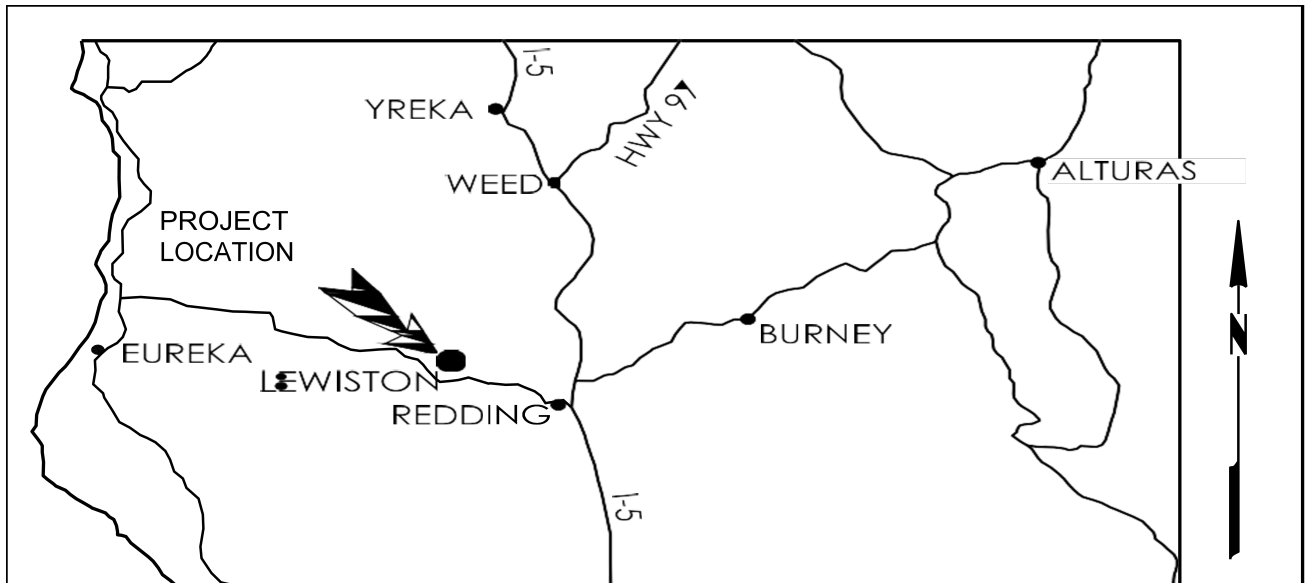

LOCATION MAP

ATTACHMENT B - FACILITY SITE MAP

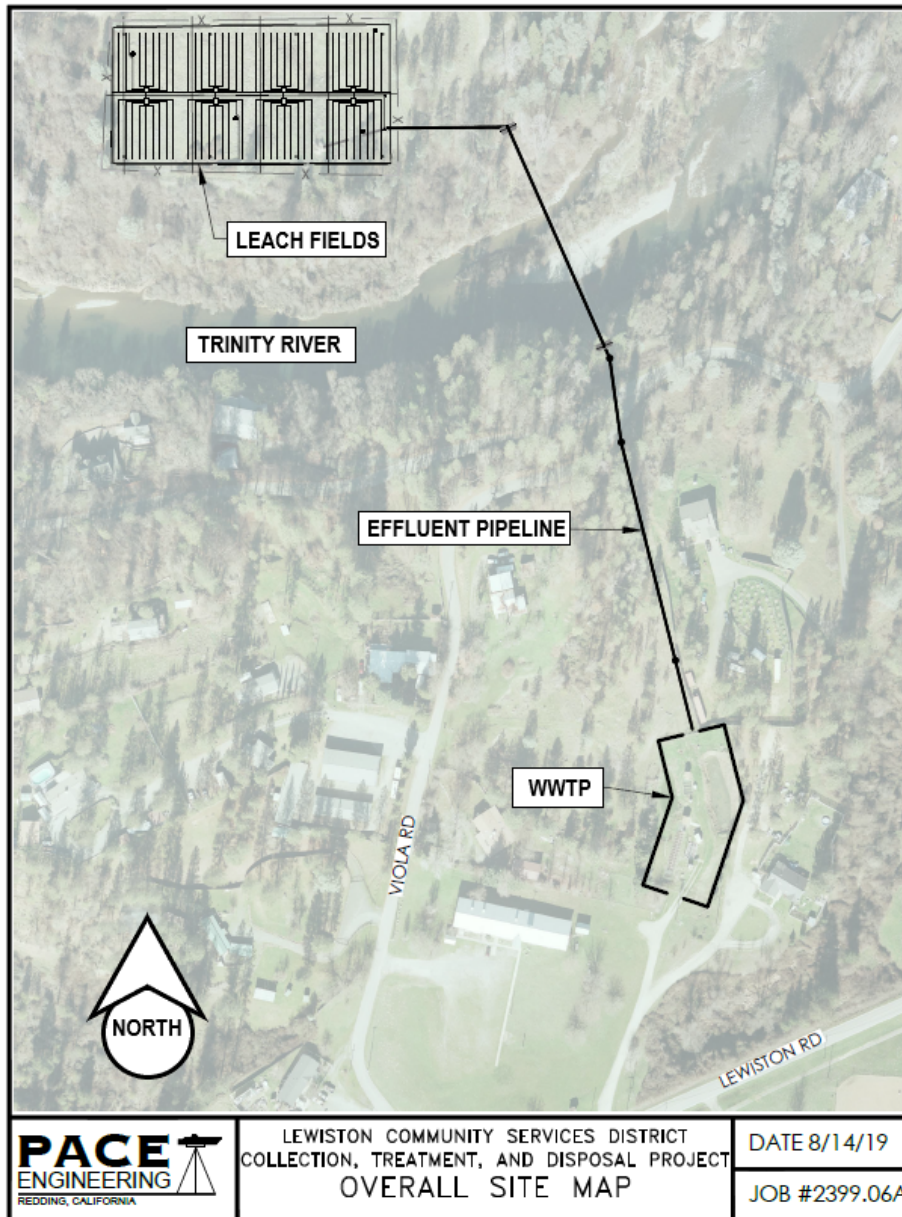

ATTACHMENT C - WWTF LAYOUT

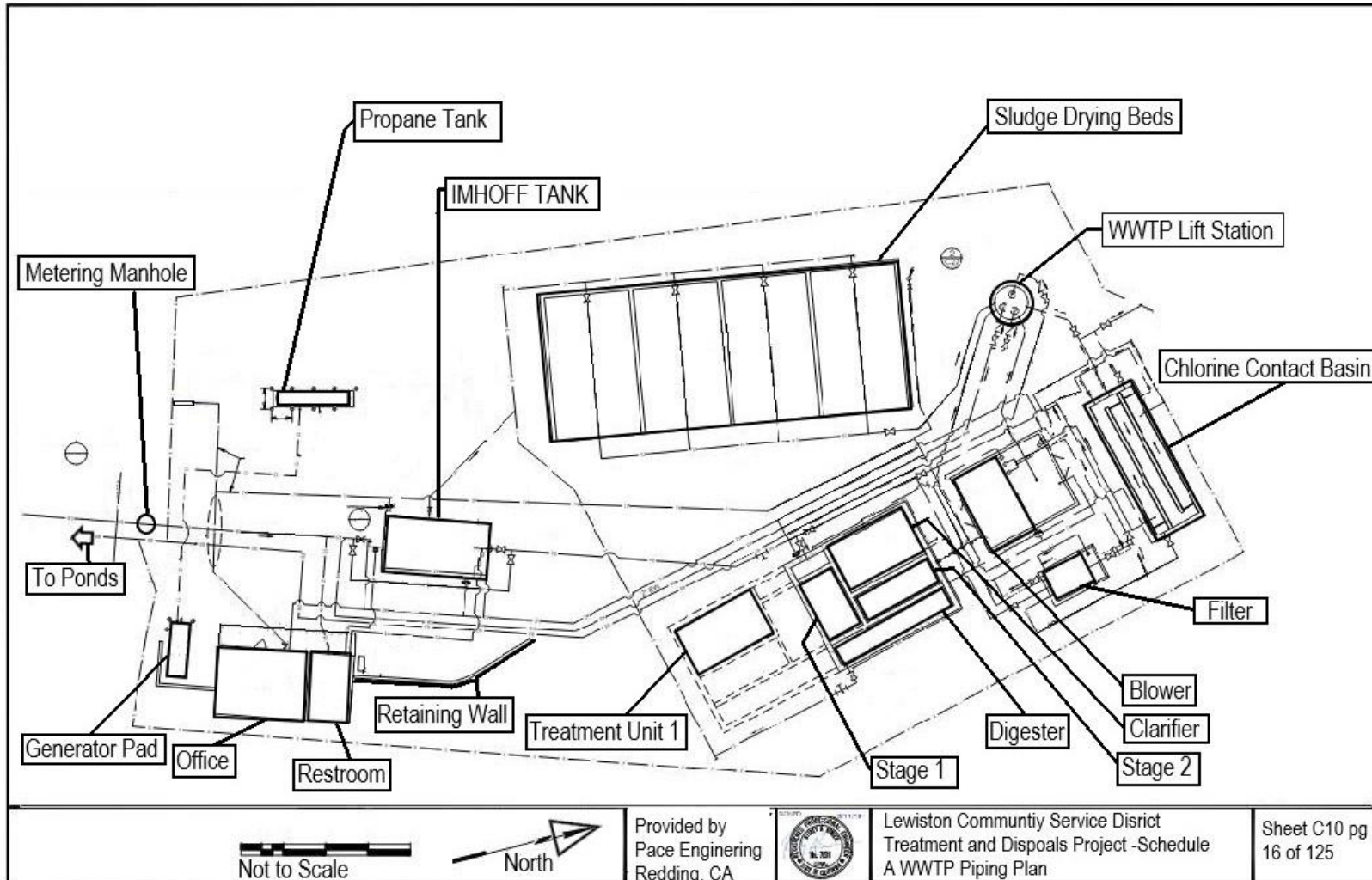

Modified by the North Coast Regional Water Quality Control Board for ADA compliance on 9/23/2020

ATTACHMENT D - FLOW SCHEMATIC

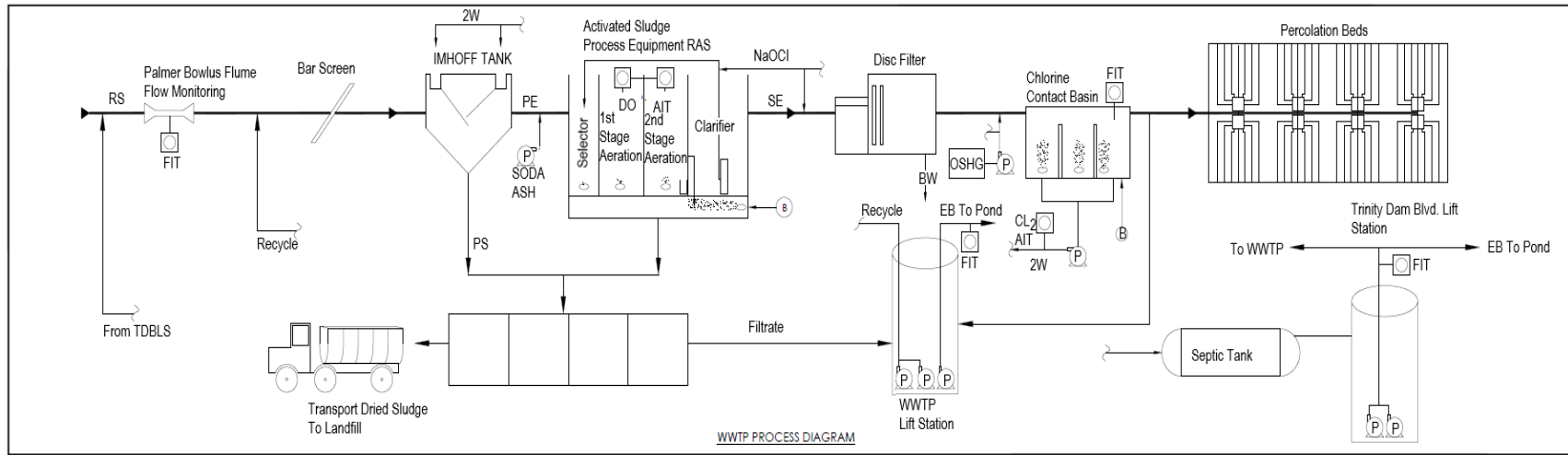

ATTACHMENT E - MONITORING AND REPORTING PROGRAM

California Water Code section 13267 authorizes the Regional Water Quality Control Board (Regional Water Board) to require technical and monitoring reports. This MRP establishes monitoring and reporting requirements, which are necessary to assure the discharges of waste that could impact water quality complies with waste discharge requirements and water quality objectives. This MRP may be modified, as necessary by the Executive Officer. Pursuant to Water Code section 13268, failure to submit the report(s) as described by this Order is a misdemeanor and may subject you to an administrative civil liability if the reports are not received by the deadline.

I. GENERAL MONITORING PROVISIONS

A. Wastewater Monitoring Provision

Composite samples may be taken by a proportional sampling device approved by the Executive Officer or by grab samples composited in proportion to flow. In compositing grab samples, the sampling interval shall not exceed 1 hour.

B. Supplemental Monitoring Provision

If the Discharger monitors any pollutant more frequently than required by this Order, the results of this monitoring shall be included in the calculation and reporting of the data submitted in the monthly and annual self-monitoring reports.

C. Laboratory Certification

Laboratories analyzing monitoring samples shall be certified by the State of California Environmental Laboratory Accreditation Program (ELAP), in accordance with Water Code section 13176, and must include quality assurance/quality control data with their reports. The Discharger may analyze pollutants with short hold times (e.g., pH, chlorine residual, settleable solids, EC, temperature etc.) in its on-site laboratory provided that the Discharger has standard operating procedures (SOPs) that identify quality assurance/quality control procedures to be followed to ensure accurate results.

D. Minimum Levels

Compliance and reasonable potential monitoring analyses shall be conducted using commercially available and reasonably achievable detection limits that are lower than the applicable effluent limitation. If no minimum level (ML) value is below the effluent limitation, the lowest ML shall be selected as the reporting level (RL).

E. Monitoring Equipment Provision

All monitoring and analysis instruments and devices used by the Discharger to fulfill this MRP shall be properly maintained and calibrated as recommended by the manufacturer to ensure their continued accuracy. The calibration interval for flow measurement devices shall not exceed 5 years.

F. Sample Documentation

All samples shall be representative of the volume and nature of the discharge or matrix of material sampled. The name of the sampler, sample type (grab or composite), time, date, location, bottle type, and any preservative used for each sample shall be recorded on the sample chain of custody form. The chain of custody form must also contain all custody information including date, time, and to whom samples were relinquished. If composite samples are collected, the basis for sampling (time or flow weighted) shall be approved by Regional Water Board staff.

G. Field Test Instruments

Field test instruments (such as those used to test pH, dissolved oxygen, and electrical conductivity) may be used provided that they are used by an ELAP certified laboratory or:

1. The user is trained in proper use and maintenance of the instruments;
2. The instruments are field calibrated prior to monitoring events at the frequency recommended by the manufacturer;
3. Instruments are serviced by the manufacturer or authorized representative at the recommended frequency; and
4. Field calibration reports are maintained and available for at least three years.

H. Duplicative Monitoring Requirements

If monitoring requirements listed below duplicate existing monitoring requirements under other orders including WDRs or waivers of WDRs, then duplication of sampling and monitoring activities are not required if the monitoring activity satisfies the requirements of this MRP. In addition to submitting the results under another order, the results shall be submitted in the reports required by this MRP.

I. Approved Test Methods

All monitoring must be conducted using approved test methods or other test methods specified in this MRP.

J. Sampling Method

Collecting composite samples is acceptable in most cases. Due to short holding times, bacteriological samples collected to verify disinfection effectiveness must be grab samples.

II. MONITORING LOCATIONS

The Discharger shall establish the following monitoring locations to demonstrate compliance with the discharge prohibitions, discharge specifications, and other requirements in this Order:

Table E-1. Monitoring Station Locations

Discharge Point Name	Monitoring Location Name	Monitoring Location Description
--	INF-001	Influent flume and sensor located prior to Imhoff tank.
--	EFF-001	Effluent monitoring location at chlorine contact basin.
001	EFF-002	Effluent monitoring location following treatment and chlorination prior to discharge to leach field.
--	LEACH-001	Visual observation of leach field.

III. MONITORING REQUIREMENTS

A. Influent

The Discharger shall measure and record the volume of influent wastewater and monitor influent at Monitoring Location INF-001 as follows:

Table E-2. Influent Flow – Monitoring Location INF-001

Parameter	Units	Sample Type	Minimum Sampling Frequency
Flow (Daily, Monthly Average)	mgd	Flow Sensor	Continuous
Biochemical Oxygen Demand (5-day @ 20°C)	mg/L	Grab	Monthly
Total Suspended Solids	mg/L	Grab	Monthly

B. Effluent Chlorine Contact Basin

The Discharger shall monitor the effluent chlorine residual at Monitoring Location EFF-001 as follows:

Table E-3. Effluent Chlorine Contact Basin – Monitoring Location EFF-001

Parameter	Units	Sample Type	Minimum Sampling Frequency
Chlorine, Total Residual	mg/L	Flow Sensor	Continuous

C. Effluent

The Discharger shall measure and record the volume of effluent wastewater and monitor treated effluent at Monitoring Location EFF-002 as follows:

Table E-4. Effluent Monitoring – Monitoring Location EFF-002

Parameter	Units	Sample Type	Minimum Sampling Frequency
Flow (Daily, Monthly Average)	Mgd	Flow Sensor	Continuous
Biochemical Oxygen Demand (5-day @ 20°C)	mg/L	Grab	Monthly
Total Suspended Solids	mg/L	Grab	Monthly
Settleable Solids	ml/L	Grab	Monthly
Chlorine, Total Residual	mg/L	Grab	Monthly
pH	Standard Units	Grab	Weekly
Total Coliform Organisms	MPN/ 100 mL	Grab	Weekly
Nitrogen, Nitrate (as N)	mg/L	Grab	Monthly
Nitrogen, Total (as N)	mg/L	Grab	Monthly

D. Leach Field Monitoring

The Discharger shall monitor for the presence or absence of surfacing effluent at Monitoring Location LEACH-001:

Table E-5. Leach Field Monitoring – Monitoring Location LEACH-001

Parameter	Units	Sample Type	Minimum Sampling Frequency
Presence or Absence of Surfacing Effluent	Feet	Measured	Weekly

E. Groundwater Monitoring

Where groundwater monitoring wells are installed, the Discharger shall monitor groundwater in the groundwater monitoring wells as follows:

Table E-6 Groundwater Monitoring – Monitoring Wells

Parameter	Units	Sample Type	Minimum Sampling Frequency
Depth to Groundwater	0.01 feet	Measured	Monthly
Total Coliform Organisms	MPN/100mL	Grab	Quarterly
Nitrogen, Total (as N)	mg/L	Grab	Quarterly
Nitrogen, Nitrate (as N)	mg/L	Grab	Quarterly

IV. REPORTING REQUIREMENTS

A. Self-Monitoring Reports (SMRs)

1. The Discharger shall submit monthly SMRs including the results for all monitoring specified in this MRP. If the Discharger monitors any pollutant more frequently than required by this Order, the results of this monitoring shall be included in the calculations and reporting of the data submitted in the SMR.
2. Monthly SMRs shall be submitted by the first day of the second calendar month, following the month of sampling. All monitoring results shall include complete laboratory data sheets for each analysis and be submitted in

conjunction with the monthly SMR. Annual summary reports shall be submitted by March 1st each year.

3. Monitoring periods for all required monitoring shall be completed according to the following schedule:

Table E-7. Monitoring Periods and Reporting Schedule

Sampling Frequency	Monitoring Period Begins On	Monitoring Period
Daily	Permit Effective Date	(Midnight through 11:59 PM) or any 24-hour period that reasonably represents a calendar day for purposes of sampling.
Weekly	Sunday following permit effective date or on permit effective date if on a Sunday	Sunday through Saturday
Monthly	First day of calendar month following permit effective date or on permit effective date if that date is first day of the month	1 st day of calendar month through last day of calendar month
Annually	January 1 following (or on) permit effective date	January 1 through December 31

4. The Discharger shall report with each sample result the applicable ML, the RL and the current MDL, as determined by the procedure in Standard Methods.
5. The Discharger shall report the results of analytical determinations for the presence of chemical constituents in a sample using the following reporting protocols:
 - a. Sample results greater than or equal to the reported ML shall be reported as measured by the laboratory (i.e., the measured chemical concentration in the sample).
 - b. Sample results less than the RL, but greater than or equal to the laboratory's MDL, shall be reported as "Detected, but Not Quantified," or DNQ. The estimated chemical concentration of the sample shall also be reported.

For the purposes of data collection, the laboratory shall write the estimated chemical concentration next to DNQ as well as the words "Estimated Concentration" (may be shortened to "Est. Conc."). The laboratory may, if such information is available, include numerical

estimates of the data quality for the reported result. Numerical estimates of data quality may be percent accuracy (+ a percentage of the reported value), numerical ranges (low to high), or any other means considered appropriate by the laboratory.

- c.** Sample results less than the laboratory's MDL shall be reported as "Not Detected," or ND.
 - d.** Dischargers are to instruct laboratories to establish calibration standards so that the ML value (or its equivalent if there is differential treatment of samples relative to calibration standards) is the lowest calibration standard. At no time is the Discharger to use analytical data derived from extrapolation beyond the lowest point of the calibration curve.
- 6.** The Discharger shall submit monthly SMRs in accordance with the following requirements:
- a.** The Discharger shall arrange all reported data in a tabular format. The data shall be summarized to clearly illustrate whether the Facility is operating in compliance with effluent limitations and other WDR requirements.
 - b.** The Discharger shall attach a cover letter to the SMR. The information contained in the cover letter shall clearly identify:

 - i. Facility name and address;
 - ii. WDID number;
 - iii. Applicable period of monitoring and reporting;
 - iv. Violations of the WDRs (identified violations must include a description of the requirement that was violated and a description of the violation);
 - v. Corrective actions taken or planned; and
 - vi. The proposed time schedule for corrective actions.
 - c.** The Monthly SMRs, Annual Report, and Source Control Activity Report must be submitted to the Regional Water Board, signed and certified as required by the General Provisions, to: NorthCoast@waterboards.ca.gov or on disk (CD or DVD) in a Portable Document Format (PDF) file in lieu of paper-sourced documents. The guidelines for electronic submittal of documents can be found on the [Regional Water Board website](https://www.waterboards.ca.gov/northcoast/publications_and_forms/available_documents/pdf/2014/ECM_Letter-Guidelines.pdf). (https://www.waterboards.ca.gov/northcoast/publications_and_forms/available_documents/pdf/2014/ECM_Letter-Guidelines.pdf)

At any time during the term of this permit, the Regional Water Board may notify the Discharger to electronically submit both technical and Self-Monitoring Reports (SMRs) to the State Water Board's GeoTracker database in searchable Portable Document Format (pdf). In addition, analytical data will be required to be uploaded to the GeoTracker database under a site-specific global identification number that will be assigned to the Discharger. Information on the GeoTracker database is provided on the [State Water Board website](#).

(https://www.waterboards.ca.gov/resources/data_databases/groundwater.html)

B. Other Reports

- 1. Annual Report.** The Discharger shall submit an annual report, as per section IV.A.6.C, to the Regional Water Board for each calendar year. The report shall be submitted by March 1 of the following year. The report shall, at a minimum, include the following:
 - a. Monitoring Data Summaries.** Both tabular and, where appropriate, graphical summaries of the monitoring data and disposal records from the previous year. If the Discharger monitors any pollutant more frequently than required by this Order, the results of this monitoring shall be included in the calculation and report of the data submitted in the SMR.
 - b. Compliance Reporting.** A comprehensive discussion of the Facility's compliance (or lack thereof) with all effluent limitations and other WDRs, and the corrective actions taken or planned, which may be needed to bring the discharge into full compliance with the Order.
 - c. Solids Reporting.** A summary report of solids pumping, handling and disposal. If the Discharger is required to monitor sludge prior to final disposal, the results of this monitoring shall be included in the summary report.
- 2. Source Control Activity Report.** The Discharger shall submit a Source Control Activity Report, as per section IV.A.6.C, to the Regional Water Board for each calendar year. The report shall describe source control activities performed by the Discharger during the calendar year, as required by General Provision VIII.F of the Order, including:
 - a.** A copy of any source control standards;
 - b.** A description of any waste hauler permit system;

- c. A summary of compliance and enforcement activities during the past year. The summary shall include the names and addresses of any industrial or commercial users under surveillance by the Discharger, an explanation of whether they were inspected, sampled, or both, the frequency of these activities at each user, and the conclusions or results from the inspection or sampling of each user.

C. Spill Notification

1. **Spills and Unauthorized Discharges.** Information regarding all spills and unauthorized discharges (except SSOs) that may endanger health or the environment shall be provided verbally to the Regional Water Board³ within 24 hours from the time the Discharger becomes aware of the circumstances and a written report shall also be provided within five (5) days of the time the Discharger becomes aware of the circumstances of the spill or unauthorized discharge.

Information to be provided verbally to the Regional Water Board includes:

- a. Name and contact information of caller;
- b. Date, time and location of spill occurrence;
- c. Estimates of spill volume, rate of flow, and spill duration, if available and reasonably accurate;
- d. Surface water bodies impacted, if any;
- e. Cause of spill, if known at the time of the notification;
- f. Cleanup actions taken or repairs made at the time of the notification;
- g. Actions taken to prevent the spill or unauthorized discharge from reoccurring; and
- h. Responding agencies.

³. The contact number of the Regional Water Board during normal business hours is (707) 576-2220. After normal business hours, spill reporting to the California Governor's Office of Emergency Services Warning Center (CalOES) will satisfy the 24 hour spill reporting requirement for the Regional Water Board. The contact number for spill reporting for the CalEMA is (800) 852-7550.

- 2. Sanitary Sewer Overflows.** Notification and reporting of sanitary sewer overflows is conducted in accordance with the requirements of State Water Resources Control Board Order No. 2006-0003-DWQ (Statewide General WDRs for Sanitary Sewer Systems), as amended by State Water Resources Control Board Order No. WQ 2013-0058-EXEC, and any revisions thereto.