

State Water Resources Control Board

November 2, 2022 Draft Cross-Connection Control Policy Handbook

Standards and Principles for California's
Public Water Systems

Adopted: **Month Day, Year**
Effective: **Month Day, Year**

California Environmental Protection Agency

Table of Contents

Acronyms and Abbreviations	1
Chapter 1 – Policy Overview.....	2
1.1 Objective	2
1.2 Applicability	2
1.3 Policy Development Background and Legal Authorities.....	2
1.3.1 California Safe Drinking Water Act	2
Chapter 2 – Background on Backflow Protection and Cross-Connection Control	6
2.1 What is a Cross-Connection?.....	6
2.2 Purpose of a Cross-Connection Control Program.....	7
2.3 Notes on Applicability of the Cross-Connection Control Policy Handbook.....	7
Chapter 3 – Standards for Backflow Protection and Cross-Connection Control.....	10
Article 1 – Definitions and General Requirements	10
3.1.1 Definitions	10
3.1.2 Applicability.....	14
3.1.3 Program for Public Water System Cross-Connection Control	14
3.1.4 Plan for Public Water System Cross-Connection Control.....	15
Article 2 – Hazard Assessments and Required Protection.....	19
3.2.1 Hazard Assessments.....	19
3.2.2 Backflow Protection Required.....	20
Article 3 – Backflow Prevention Assemblies	23
3.3.1 Standards for Types of Backflow Protection.....	23
3.3.2 Installation Criteria for Backflow Protection	23
3.3.3 Field Testing and Repair of Backflow Prevention Assemblies and Air Gap Inspection	24
Article 4 – Backflow Prevention Assembly Testers and Cross-Connection Control Specialists	26
3.4.1 Backflow Prevention Assembly Tester Certification	26
3.4.2 Cross-Connection Control Specialist Certification	30
Article 5 – Recordkeeping, Backflow Incident Response, and Notification	33
3.5.1 Recordkeeping.....	33
3.5.2 Backflow Incident Response Procedure	33
3.5.3 Backflow Incident Notification	34
Appendix	36

Appendix

Appendix A: Assembly Bills 1671 (2017, Chapter 533) and 1180 (2019, Chapter 455)

Appendix B: 2019 California Plumbing Code, Section 603.3.1

Appendix C: Backflow Prevention Assembly diagrams

Appendix D: High Hazard Premises

Appendix E: General Range of Knowledge for Cross-Connection Control Specialists

Appendix F: Example Backflow Incident Reporting Form

Appendix G: Related Statutes and Regulations

Acronyms and Abbreviations

As used in this policy, acronyms and abbreviations reference the following:

<i>Acronym or Abbreviation</i>	<i>Meaning</i>
AB	Assembly Bill
AG	Air Gap separation
BAT	Best Available Technology
BPA	Backflow Prevention Assembly
Bus. & Prof. Code	Business and Professional Code
CA	California
CBSC	California Building Standards Commission
CCCPH	Cross-Connection Control Policy Handbook
CCR	California Code of Regulations
C.F.R.	Code of Federal Regulations
CHSC	California Health and Safety Code
Civ. Code	Civil Code
DC	Double Check valve backflow prevention assembly
DCDA	Double Check Detector backflow prevention Assembly
DCDA-II	Double Check Detector backflow prevention Assembly – type II
Division	Division of Drinking Water
EPA	Environmental Protection Agency
Gov. Code	Government Code
MCL	Maximum Contaminant Level
Pen. Code	Penal Code
PVB	Pressure Vacuum Breaker backsiphonage prevention assembly
PWS	Public Water System
RP	Reduced Pressure principle backflow prevention assembly
RPDA	Reduced Pressure principle Detector backflow prevention Assembly
RPDA-II	Reduced Pressure principle Detector backflow prevention Assembly – type II
RW	Recycled Water
SB	Senate Bill
SDWA	Safe Drinking Water Act
State Water Board	State Water Resources Control Board
SVB	Spill-resistant Pressure Vacuum Breaker backsiphonage prevention assembly
U.S.	United States

Chapter 1 – Policy Overview

1.1 Objective

The primary objective of the Cross-Connection Control Policy Handbook (CCCPH) is the protection of public health through the establishment of standards intended to ensure a public water system's (PWS) drinking water distribution system will not be subject to the backflow of liquids, gases, or other substances into the distribution system. In addition, by providing basic educational information on backflow prevention, the State Water Resources Control Board (State Water Board) intends to build a foundation of awareness within the regulated community regarding the importance of backflow protection and cross-connection control, leading to the implementation of a robust cross-connection control program by PWS.

1.2 Applicability

The CCCPH and its standards applies to all California PWS, as defined in California's Health and Safety Code (CHSC, section 116275 (h)). Compliance with this CCCPH is mandatory for all California's PWS.

1.3 Policy Development Background and Legal Authorities

Through the adoption of the CCCPH, the State Water Board is exercising its authority, under California's Safe Drinking Water Act¹ (SDWA), to establish enforceable standards applicable to California's PWS. Failure to comply with the CCCPH may result in the issuance of compliance, enforcement, or other corrective actions against a PWS.

1.3.1 California Safe Drinking Water Act

On October 6, 2017, Assembly Bill 1671 (AB 1671) was approved and filed with the Secretary of State (see Appendix A). AB 1671 amended California's SDWA through the establishment of CHSC sections 116407 and 116555.5. AB 1671 also amended section 116810 of the CHSC, which is briefly discussed in [Appendix G](#).

On October 2, 2019, Assembly Bill 1180 (AB 1180) was approved and filed with the Secretary of State. AB 1180 amended Section 116407 of the CHSC and added section 13521.2 to the Water Code. AB 1180 requires that the CCCPH include provisions for the use of a swivel or changeover device (swivel-ell).

¹ CHSC, div. 104, pt. 12, ch. 4, section 116270 et seq.

AB 1671 and 1180 established the following:

- The State Water Board was mandated to adopt standards for backflow protection and cross-connection control by January 1, 2020.
- The State Water Board may establish standards for backflow protection and cross-connection control through the adoption of the CCCPH, with the CCCPH not being subject to the requirements of the CA Administrative Procedure Act².
- If standards for backflow protection and cross-connection control are established via the CCCPH, the State Water Board must:
 - Consult with state and local agencies and persons, identified by the State Water Board, as having expertise on the subject of backflow protection and cross-connection control.
 - Hold at least two public hearings before adoption of the CCCPH.
 - Post the CCCPH on the State Water Board website.
- Upon the effective date of the CCCPH, the previous cross-connection control standards³ become inoperative, and would be repealed 90 days later, unless the State Water Board determines not to repeal a specific existing regulation.
- Mandates that a PWS must implement a cross-connection control program that complies with the standards adopted by the State Water Board.
- Use of a swivel-ell will be consistent with any notification and backflow protection provisions contained in the CCCPH.

The development of the CCCPH included consultation with stakeholders, including state and local agencies, on an array of subjects related to cross-connection control, consistent with the statutory mandate, as well as consideration of input from other stakeholders and the general public in a February 2020 workshop.

Prior to adoption of the CCCPH, in accordance with the statutory mandate, the State Water Board held **two** public hearings - one on April 27, 2021, and the other **on Month Day, 2022**.

Pursuant to sections 116407 and 116555.5 of the CHSC, the State Water Board chose to adopt standards for backflow protection and cross-connection control through the adoption of this CCCPH, which became effective **Month Day, Year**.

² Gov. Code, tit. 2, div. 3, pt. 1, ch. 3.5, section 11340 et seq.

³ Cal. Code Regs., tit. 17, div. 1, ch. 5, subch. 1, grp. 4, arts. 1 & 2, section 7583 et seq.

Aside from the mandates of AB 1671 related to the State Water Board's need and authority to develop and adopt an enforceable CCCPH, there are long-standing statutory mandates in California's SDWA concerning backflow protection and cross-connection control, some of which are summarized below.

- The State Water Board is required to adopt regulations for the control of cross-connections that it determines to be necessary for ensuring public water systems "distribute a reliable and adequate supply of pure, wholesome, potable, and healthy water." (CHSC section 116375, subd. (c))
- Any person who owns a PWS is required to ensure that the distribution system will not be subject to backflow under normal operating conditions. (CHSC section 116555, subd. (a)(2))

Prior to AB 1671 and the adoption of this CCCPH, California's regulations pertaining to cross-connection control were set forth in regulations in CCR Title 17⁴, which were adopted in 1987 with minor revisions in 2000. Although still protective to public health, the CCR Title 17 cross-connection regulations required updating as both the drinking water and cross-connection control industries evolved. This CCCPH updates those regulations, which as previously noted are no longer operative following the adoption of the CCCPH.

The State Water Board may update its standards for backflow protection and cross-connection control through revisions of the CCCPH. Prior to adopting substantive revisions to the CCCPH, the State Water Board will consult with state and local agencies and persons identified as having expertise on the subject by the State Water Board, and the State Water Board will hold at least one public hearing to consider public comments.

⁴ Cal. Code Regs., tit. 17, div. 1, ch. 5, subch. 1, grp. 4, arts. 1 & 2, section 7583 et seq.

This page intentionally left blank

Chapter 2 – Background on Backflow Protection and Cross-Connection Control

2.1 What is a Cross-Connection?

A cross-connection is an interconnection between a potable water supply and a non-potable source via any actual or potential connection or structural arrangement between a public water system and any source or distribution system containing liquid, gas, or other substances not from an approved water supply. Bypass arrangements, jumper connections, removable sections, swivel-ell or change-over devices and other temporary or permanent devices through which, or because of which backflow can occur are considered to be cross-connections⁵.

Backflow is the undesired or unintended reversal of flow of water and/or other liquids, gases, or other substances into a public water system's distribution system or approved water supply.

The presence of a cross-connection represents a location in a distribution system through which backflow of contaminants or pollutants can occur. Backflow occurs when a non-potable source is at a greater pressure than the potable water distribution system. Backflow can occur from either backsiphonage or backpressure. Backsiphonage occurs when a non-potable source enters the drinking water supply due to negative (i.e., sub-atmospheric) distribution system pressure. Backpressure occurs when the pressure from a non-potable source exceeds the pressure in the potable water distribution system.

Backsiphonage may be caused by a variety of circumstances, such as main breaks, flushing, pump failure, or emergency firefighting water demand. Backpressure may occur when heating, cooling, waste disposal, or industrial manufacturing systems are connected to potable supplies and the pressure in the external system exceeds the pressure in the distribution system. Both situations act to change the direction of water, which normally flows from the distribution system to the customer, so that non-potable substances from industrial, commercial, or residential premises flows back into the distribution system through a cross-connection.

Cross-connections are not limited to industrial or commercial facilities. Submerged inlets are found on many common plumbing fixtures and are sometimes necessary features of the fixtures if they are to function properly. Examples of this type of design are siphon-jet urinals or water closets, flushing rim slop sinks, and dental cuspidors. Older bathtubs and lavatories may have supply inlets below the flood level rims, but

⁵ California Department of Health Services (DHS), Public Water Supply Branch. (1988). *Guidance Manual for cross connection Control Program (Green Manual)*. California Department of Health Services.

modern sanitary design has minimized or eliminated this cross-connection in new fixtures. Chemical and industrial process vats sometimes have submerged inlets where the water pressure is used as an aid in diffusion, dispersion and agitation of the vat contents. Even though a supply pipe may be installed above a vat, backsiphonage can still occur. Siphon action has been shown to raise a liquid in a pipe such as water almost 34 feet. Some submerged inlets difficult to control are those which are not apparent until a significant change in water level occurs or where a supply may be conveniently extended below the liquid surface by means of a hose or auxiliary piping. A submerged inlet may be created in numerous ways, and its detection may be difficult.

Chemical and biological contaminants have caused illness and deaths during known incidents of backflow, with contamination affecting several service connections, and the number of incidents reported is believed to be a small percentage of the total number of backflow incidents that actually occur. The public health risk from cross-connections and backflow is a function of a variety of factors including cross-connection and backflow occurrence, type and amount of contaminants, and the health effects of the contaminants.

2.2 Purpose of a Cross-Connection Control Program

The purpose of a cross-connection control program is to prevent the occurrence of backflow into a public water system's distribution system in order to protect customers from contamination or pollution from any on-site hazards. Properly installed and maintained backflow prevention assemblies (BPAs), devices or methods provides protection against the threat posed by many conditions typically found on a user's premise.

The use of approved BPAs ensures that the appropriate performance evaluation of the assembly has been conducted. It is important and required by the CCCPH to select and properly install an approved assembly that is capable of protecting the distribution system from the hazard identified. The success of a program depends on individuals that are knowledgeable about cross-connection control to identify actual and potential hazards, apply principles of backflow protection and prevention, and implement cross-connection control policies and procedures. A successful program will have ongoing surveillance of a public water system to ensure BPAs or methods are working and identify new hazards or changes in the distribution system. Certified specialists are needed to properly evaluate the degree of hazard that exists in the distribution system. Hazards typically identified in distribution systems along with the required level of protection are specified in Chapter 3 of the CCCPH.

2.3 Notes on Applicability of the Cross-Connection Control Policy Handbook

The CCCPH provides the basis for regulating the use and management of cross-connection control programs and BPAs in PWS, and related requirements for supporting programs and policies. Activities or uses outside of the scope of the

authority of the State Water Board to regulate PWS are not regulated by the CCCPH, including California Plumbing Code requirements and definitions not related to PWS.

Recycled water cross-connection control installations and programs for the purposes of protecting the recycled water supply are not regulated by the CCCPH, although a PWS that uses recycled water is regulated by the CCCPH to ensure that a PWS's drinking water system has adequate backflow protection from a recycled water system.

Water systems that do not meet the definition of a PWS (e.g. "State Small Water Systems" per CCR Title 22, Article 3) are not regulated by the CCCPH, although they may need to comply with the California Plumbing Code, local health agencies, and other laws or entities.

Transient noncommunity and nontransient noncommunity systems may need to have internal cross-connection control programs within the user premises. The California Plumbing Code and the CCCPH will overlap in protection of these user premises, and PWS must comply with both the California Plumbing Code and CCCPH.

Noncommunity water systems must have the ability to enforce backflow protection within the premises, thus compliance with the California Plumbing Code can be verified by the PWS and used for compliance with the CCCPH. Compliance with the CCCPH is documented through the hazard assessment and maintenance of an inventory of field-testable assemblies devices, and methods. Annual field testing of testable assemblies is required. Where the minimum backflow protection differs between the California Plumbing Code and the CCCPH, the more protective minimum protection will be required.

This page intentionally left blank

Chapter 3 – Standards for Backflow Protection and Cross-Connection Control

Article 1 – Definitions and General Requirements

3.1.1 Definitions

The following definitions apply to the terms used in the CCCPH:

“**Air-gap separation**” or “**AG**” means a physical vertical separation of at least two (2) times the effective pipe diameter between the free-flowing discharge end of a potable water supply pipeline and the flood level of an open or non-pressurized receiving vessel, and in no case less than one (1) inch.

“**Approved water supply**” means a water source that has been approved by the State Water Board for domestic use in a public water system and designated as such in a domestic water supply permit issued pursuant to section 116525 of the CHSC.

“**Auxiliary water supply**” means a source of water, other than an approved water supply, that is either used or equipped to be used as a water supply and is located on the premises of, or available to, a water user.

“**Backflow**” means an undesired or unintended reversal of flow of water and/or other liquids, gases, or other substances into a public water system’s distribution system or approved water supply.

“**Backflow prevention assembly**” or “**BPA**” means a mechanical assembly designed and constructed to prevent backflow, such that while in-line it can be maintained and its ability to prevent backflow, as designed, can be field tested, inspected and evaluated.

“**Backflow prevention assembly tester**” means a person who is certified as a backflow prevention assembly tester pursuant to this Chapter.

“**Community water system**” means a public water system that serves at least 15 service connections used by yearlong residents or regularly serves at least 25 yearlong residents of the area served by the system.

“**Contact hour**” means not less than 50 minutes of a continuing education course.

“**Continuing education course**” means a presentation or training that transmits information related to cross-connection control programs and backflow prevention and protection.

“**Cross-connection**” means any actual or potential connection or structural arrangement between a public water system, including a piping system connected to

the public water system and located on the premises of a water user or available to the water user, and any source or distribution system containing liquid, gas, or other substances not from an approved water supply.

“Cross-connection control specialist” means a person who is certified as a cross-connection control specialist pursuant to this Chapter.

“Distribution system” has the same meaning as defined in section 63750.50 of CCR, Title 22, Division 4, Chapter 2.

“Double check detector backflow prevention assembly” or **“DCDA”** means a double check valve backflow prevention assembly that includes a bypass with a water meter and double check backflow prevention assembly, with the bypass’s water meter accurately registering flow rates up to two gallons per minute and visually indicating all rates of flow. This type of assembly may only be used to isolate low hazard cross-connections. When a double check valve backflow prevention assembly or DC is required or referenced in the CCCPH, this type of assembly may be substituted if appropriate. See Diagram 1, Appendix C.

“Double check detector backflow prevention assembly – type II” or **“DCDA-II”** means a double check valve backflow prevention assembly that includes a bypass around the second check, with the bypass having a single check valve and a water meter accurately registering flow rates up to two gallons per minute and visually indicating all rates of flow. This type of assembly may only be used to isolate low hazard cross-connections. When a double check valve backflow prevention assembly or DC is required or referenced in the CCCPH, this type of assembly may be substituted if appropriate. See Diagram 2, Appendix C.

“Double check valve backflow prevention assembly” or **“DC”** means an assembly consisting of two independently-acting internally-loaded check valves, with tightly closing shut-off valves located at each end of the assembly (upstream and downstream of the two check valves), and fitted with test cocks that enable accurate field testing of the assembly. This type of assembly may only be used to isolate low hazard cross-connections. See Diagram 3, Appendix C.

“Existing public water system” or **“existing PWS”** means a public water system initially permitted on or before *[insert initial effective date]* as a public water system by the State Water Board.

“Hazard Assessment” means an evaluation of a user premises designed to evaluate the types and degrees of hazard at a user’s premises.

“High hazard cross-connection” means a cross-connection that poses a threat to the potability or safety of the public water supply. Materials entering the public water supply through a high hazard cross-connection are contaminants or health hazards. See Appendix D for some examples.

“Low hazard cross-connection” means a cross-connection that has been found to not pose a threat to the potability or safety of the public water supply but may adversely affect the aesthetic quality of the potable water supply. Materials entering the public water supply through a low hazard cross-connection are pollutants or non-health hazards.

“New public water system” or **“new PWS”** means a public water system initially permitted after *[insert initial effective date]* as a public water system by the State Water Board. A new public water system includes a public water system receiving a new permit because of a change in ownership.

“Noncommunity water system” means a public water system that is not a community water system.

“Nontransient noncommunity water system” means a public water system that is not a community water system and that regularly serves at least 25 of the same persons over six months per year.

“Premises containment” means protection of a public water system’s distribution system from backflow from a user’s premises through the installation of one or more air gaps or backflow prevention assemblies, installed as close as practical to the user’s service connection, in a manner that isolates the water user’s water supply from the public water system’s distribution system.

“Pressure vacuum breaker backsiphonage prevention assembly” or **“PVB”** means an assembly with an independently-acting internally-loaded check valve and an independently-acting loaded air inlet valve located on the discharge side of the check valve; with test cocks and tightly closing shutoff valves located at each end of the assembly that enable accurate field testing of the assembly. This type of assembly may only be used for protection from backsiphonage and is not to be used to protect from backpressure. See Diagram 4, Appendix C.

“Public water system” or **“PWS”** has the same meaning as defined in section 116275(h) of the CHSC.

“Recycled Water” is a wastewater which as a result of treatment is suitable for uses other than potable use.

“Reduced pressure principle backflow prevention assembly” or **“RP”** means an assembly with two independently acting internally-loaded check valves, with a hydraulically operating mechanically independent differential-pressure relief valve located between the check valves and below the upstream check valve. The assembly shall have shut-off valves located upstream and downstream of the two check-valves, and test cocks to enable accurate field testing of the assembly. See Diagram 5, Appendix C.

“Reduced pressure principle detector backflow prevention assembly” or **“RPDA”** means a reduced pressure principle backflow prevention assembly that

includes a bypass with a water meter and reduced pressure principle backflow prevention assembly, with the bypass's water meter accurately registering flow rates up to two gallons per minute and visually indicating all rates of flow. When a reduced pressure principle backflow prevention assembly or RP is required or referenced in the CCCPH, this type of assembly may be substituted if appropriate. See Diagram 6, Appendix C.

“Reduced pressure principle detector backflow prevention assembly – type II” or **“RPDA-II”** means a reduced pressure principle backflow prevention assembly that includes a bypass around the second check, with the bypass having a single check valve and a water meter accurately registering flow rates up to two gallons per minute and visually indicating all rates of flow. When a reduced pressure principle backflow prevention assembly or RP is required or referenced in the CCCPH, this type of assembly may be substituted if appropriate. See Diagram 7, Appendix C.

“Spill-resistant pressure vacuum breaker backsiphonage prevention assembly” or **“SVB”** means an assembly with an independently-acting internally-loaded check valve and an independently-acting loaded air inlet valve located on the discharge side of the check valve; with shutoff valves at each end and a test cock and bleed/vent port, to enable accurate field testing of the assembly. This type of assembly may only be used for protection from backsiphonage and is not to be used to protect from backpressure. See Diagram 8, Appendix C.

“State Water Board”, unless otherwise specified, means the State Water Resources Control Board or the local primacy agency having been delegated the authority to enforce the requirements of this Chapter by the State Water Resources Control Board.

“Swivel-Ell” means a reduced pressure principle backflow prevention assembly combined with a changeover piping configuration (swivel-ell connection) designed and constructed pursuant to this Chapter. See design and construction criteria, as well as Diagrams 9a and 9b, Appendix C.

“Transient noncommunity water system” means a noncommunity water system that does not regularly serve at least 25 of the same persons over six months per year.

“User premises” means the property under the ownership or control of a water user and is served, or is readily capable of being served, with water via a service connection with a public water system.

“User’s service connection” means either the point where a water user’s piping is connected to a water system or the point in a water system where the approved water supply can be protected from uses of the approved water supply using an air gap or backflow prevention assembly.

“User Supervisor” means a person designated by a water user to oversee a water use site and responsible for the avoidance of cross-connections.

“Water supplier” means a person who owns or operates a public water system.

“Water user” means a person or entity who is authorized to receive water from a public water system.

3.1.2 Applicability

A public water systems (PWS) must comply with the requirements of the CCCPH.

3.1.3 Program for Public Water System Cross-Connection Control

(a) A PWS must protect the public water supply through implementation and enforcement of a cross-connection control program. Unless otherwise specified by this Chapter or directed by the State Water Board, a PWS may implement its cross-connection control program, in whole or in part, either directly or by way of contract or agreement with another party. The cross-connection control program must include at a minimum the following elements:

(1) **Operating rules or ordinances** – Each PWS must have operating rules, ordinances, by-laws or a resolution to implement the cross-connection program. The PWS must have legal authority to implement corrective actions in the event a water user fails to comply in a timely manner with the PWS’s provisions regarding the installation, inspection, field testing, or maintenance of BPAs required pursuant to this Chapter. Such corrective actions must include the PWS ability to perform at least one of the following:

- (A) deny or discontinue water service to a water user,
- (B) install, inspect, field test, and/or maintain a BPA at a water user’s premises, or
- (C) otherwise address in a timely manner a failure to comply with the cross-connection control program.

(2) **Cross-Connection Control Program Coordinator** – The PWS must designate at least one individual involved in the development of and be responsible for the reporting, tracking, and other administration duties of its cross-connection control program. For PWS with more than 3,000 service connections the Cross-Connection Control Program Coordinator must be a cross-connection control specialist.

(3) **Hazard Assessments** – The PWS must survey its service area and conduct hazard assessments per Article 2 of this Chapter that identifies actual or potential cross-connection hazards, degree of hazard, and any backflow protection needed.

(4) **Backflow Prevention** – The PWS must ensure that actual and potential cross-connections are eliminated when possible or controlled by the installation of approved BPAs or AG’s consistent with the requirements of the Article 3 of this Chapter.

(5) **Certified Backflow Prevention Assembly Testers and Certified Cross-Connection Control Specialists** – The PWS must ensure all backflow

prevention assembly testers and cross-connection control specialists used are certified per Article 4 of this Chapter.

(6) **Backflow Prevention Assembly Testing** – The PWS must develop and implement a procedure for ensuring all BPAs are field tested, inspected, and maintained and AG's are inspected and maintained in accordance with CCCPH section 3.3.3.

(7) **Recordkeeping** – The PWS must develop and implement a recordkeeping system in accordance with CCCPH section 3.5.1.

(8) **Backflow Incident Response, Reporting and Notification** – The PWS must develop and implement procedures for investigating and responding to suspected or actual backflow incidents in accordance with Article 5 of this chapter.

(9) **Public Outreach and Education** – The PWS must implement a cross-connection control public outreach and education program element that includes educating staff, customers, and the community about backflow protection and cross-connection control. The PWS may implement this requirement through a variety of methods which may include providing information on cross-connection control and backflow protection in periodic water bill inserts, pamphlet distribution, new customer documentation, email, and consumer confidence reports.

(10) **Local Entity Coordination** – The PWS must coordinate with applicable local entities that are involved in either cross-connection control or public health protection to ensure hazard assessments can be performed and appropriate backflow protection is provided, and provide assistance in the investigation of backflow incidents. Local entities include but are not limited to plumbing, permitting, or health officials, law enforcement, fire departments, maintenance, and public and private entities.

(b) The cross-connection control program must be developed in consultation with a cross-connection control specialist if:

- (1) The PWS has 1,000 or more service connections, or
- (2) required by the State Water Board.

(c) A PWS must have at least one cross-connection control specialist as a permanent or contracted employee of the PWS, and that specialist must be able to be contacted within one hour, if:

- (1) The PWS has 3,000 or more service connections, or
- (2) the PWS has less than 3,000 service connections and is directed by the State Water Board based on hazard assessments conducted pursuant to CCCPH section 3.2.1. or the PWS's history of backflow incidents.

3.1.4 Plan for Public Water System Cross-Connection Control

(a) After adoption of the CCCPH, each PWS must submit a written Cross-Connection Control Plan for State Water Board review in accordance with the following schedule:

- (1) An Existing PWS must submit the Cross-Connection Control Plan no later than 12 months after the adoption of the CCCPH.
- (2) A new PWS must submit the Cross-Connection Control Plan for review and approval prior to issuance of a domestic water supply permit.

A PWS may submit a written request to the State Water Board for an extension of the deadline for submittal of its initial Cross-Connection Control Plan. The PWS's application must include a written description of the need for an extension. Approval of an extension will be at the sole discretion of the State Water Board.

(b) The Cross-Connection Control Plan for a community water system must include, at a minimum, the following cross-connection control program procedures and documentation:

- (1) a description of how the community water system will achieve and maintain compliance with each requirement in this Chapter;
- (2) a description of the process, personnel, and timeframes for completing initial and ongoing hazard assessments pursuant to CCCPH section 3.2.1;
- (3) a description of the legal authority pursuant to CCCPH section 3.1.3 to implement corrective actions in the event a water user fails to comply in a timely manner with the provisions of the PWS's cross-connection control program;
- (4) a description of the process and timeframes for ensuring each BPA is inspected and field tested and AG is inspected, at a frequency no less than required by this Chapter;
- (5) a description of the process and timeframe for ensuring each non-testable backflow preventer for internal protection that is under the PWS ownership or administration is installed and maintained according to the California Plumbing Code;
- (6) a description of the process for ensuring individuals field testing, inspecting, and/or maintaining BPAs are no less qualified than required by this Chapter, including but not limited to confirmation of the individual's:
 - (A) certification as a backflow prevention assembly tester,
 - (B) field test kit or gage equipment accuracy verification, and
 - (C) BPA field test result reports;
- (7) a description of the procedures and timeframes of activities for responding to backflow incidents, including notification of customers, and reporting of backflow incidents pursuant to CCCPH section 3.5.2;
- (8) contact information for cross-connection control personnel including any cross-connection control program coordinator and specialist;
- (9) a description of the tracking system that maintains current and relevant information, including:
 - (A) recordkeeping information required pursuant to CCCPH section 3.5.1,
 - (B) location and type of each BPA, and
 - (C) highest threat potential hazard from which a given BPA is protecting the public water system distribution system;

(10) for user supervisors, if used, the required information pursuant to CCCPH section 3.2.2 (f);

(11) the corrective actions, including timeframes for the corrective actions, that a community water system will implement when:

- (A) a cross-connection exists and the BPA installed is not commensurate with the user premises' hazard or no BPA has been installed, or
- (B) a BPA needs to be replaced or maintained;

(12) a description of the public outreach and education program to comply with CCCPH section 3.1.3(a)(9); and

(13) the procedures for coordination with local entities (e.g., building officials, plumbing officials, etc.);

(c) The Cross-Connection Control Plan for a noncommunity water system must include, at a minimum, the following cross-connection control program procedures and documentation:

(1) a description of how the noncommunity water system will achieve and maintain compliance with each requirement in this Chapter that is applicable to the noncommunity water system;

(2) a description of the process, personnel, and timeframes for completing initial and ongoing hazard assessments pursuant to CCCPH section 3.2.1;

(3) a description of the legal authority pursuant to CCCPH section 3.1.3 to implement corrective actions in the event a water user fails to comply in a timely manner with the provisions of the PWS's cross-connection control program;

(4) a description of the process and timeframes for ensuring each BPA is inspected and field tested and AG is inspected, at a frequency no less than required by this Chapter;

(5) a description of the process and timeframe for ensuring each non-testable backflow preventer for internal protection that is under the PWS ownership or administration is installed and maintained according to the California Plumbing Code;

(6) a description of the process for ensuring individuals field testing, inspecting, and/or maintaining BPAs are no less qualified than required by this Chapter, including but not limited to confirmation of the individual's;

- (A) certification as a backflow prevention assembly tester,
- (B) field test kit or gage equipment accuracy verification, and
- (C) BPA field test result reports;

- (7) a description of the procedures and timeframes of activities for responding to backflow incidents, including notification of customers, and reporting of backflow incidents pursuant to CCCPH section 3.5.2;
 - (8) contact information for cross-connection control personnel including the cross-connection control program coordinator;
 - (9) maintaining a tracking system with current and relevant information, including:
 - (A) recordkeeping information required pursuant to CCCPH section 3.5.1,
 - (B) location and type of each BPA,
 - (C) location and type of each non-testable backflow preventers used for internal protection in accordance with the California Plumbing Code, if applicable, and
 - (D) potential hazard from which a BPA is protecting the public water system distribution system;
 - (10) for user supervisors, if used, the required information pursuant to CCCPH section 3.2.2 (f);
 - (11) the corrective actions, including timeframes for the corrective actions, that a noncommunity water system will implement when:
 - (A) a cross-connection exists and the BPA installed is not commensurate with the user premises' hazard or no BPA has been installed, or
 - (B) a BPA or non-testable backflow preventer needs to be replaced or maintained;
 - (12) a description of the public outreach and education program to comply with CCCPH section 3.1.3(a)(9); and,
 - (13) the procedures for coordination with local entities (e.g., local health departments with internal cross-connection control programs, building officials, plumbing officials, etc.).
- (d) A PWS must ensure its Cross-Connection Control Plan is, at all times, representative of the current operation of its Cross-Connection Control program. The PWS must make its Cross-Connection Control Plan available to the State Water Board for review upon request. If a PWS makes a substantive revision to its Cross-Connection Control Plan, the PWS must submit the revised Cross-Connection Control Plan to the State Water Board for review.

Article 2 – Hazard Assessments and Required Protection

3.2.1 Hazard Assessments

(a) To evaluate the potential for backflow into the public water system, each community water system must conduct an initial hazard assessment of the user premises within its service area and each noncommunity water system must conduct an initial hazard assessment of its water distribution system. The hazard assessment must consider as needed:

- (1) The existence of cross-connections;
- (2) the type and use of materials handled and present, or likely to be, on the user premises;
- (3) the degree of piping system complexity and accessibility;
- (4) access to auxiliary water supplies, pumping systems, or pressure systems;
- (5) distribution system conditions that increase the likelihood of a backflow event (e.g., hydraulic gradient differences impacted by main breaks and high water-demand situations, multiple service connections that may result in flow-through conditions, etc.);
- (6) user premises accessibility;
- (7) any previous backflow incidents on the user premises; and
- (8) the requirements and information provided in the CCCPH.

(b) Each hazard assessment must identify the degree of hazard to the PWS's distribution system as either a high hazard cross-connection, a low hazard cross-connection, or having no hazard. Examples of some high hazard cross-connection activities may be found in Appendix D.

(c) The hazard assessment must determine whether an existing BPA (if any) provides adequate protection based on the degree of hazard.

(d) Hazard assessments completed prior to the adoption of the CCCPH may be considered as an initial hazard assessment provided that such hazard assessments and associated backflow protection provide protection consistent with the CCCPH and the PWS describes their review of these assessments in the Cross-Connection Control Plan required in CCCPH section 3.1.4.

(e) Subsequent to the initial hazard assessment described in subsection (a), a community water system must perform a follow-up hazard assessment under the following criteria:

- (1) if a user premises changes account holder, excluding single-family residences;
- (2) if a user premises is newly connected to the PWS;
- (3) if evidence exists of changes in the activities or materials on a user's premises;
- (4) if backflow from a user's premises occurs;

- (5) periodically, as identified in the PWS's Cross-Connection Control Plan required pursuant to CCCPH section 3.1.4.;
- (6) if the State Water Board requests a hazard assessment of a user's premises; and
- (7) if the PWS concludes an existing hazard assessment may no longer accurately represent the degree of hazard.

(f) Noncommunity water systems must conduct an initial or follow-up hazard assessment within two years of the adoption of the CCCPH.

(g) Noncommunity water system must conduct a follow-up hazard assessment of its water distribution system if any changes are made that could result in a cross-connection or any backflow incidents occur.

(h) A cross-connection control specialist must review or conduct each initial and follow-up hazard assessment pursuant to this section and make a written finding that, in the specialist's judgment based on cross-connection control principles, the PWS's hazard assessment properly identified all hazards at the time of the assessment, the appropriate degree of hazards, and the corresponding backflow protection.

3.2.2 Backflow Protection Required

(a) A PWS must ensure its distribution system is protected from backflow from identified hazards through the proper installation, continued operation, and field testing of an approved BPA (see Article 3 for installation and approved BPA criteria).

(b) The BPA installed must be no less protective than that which is commensurate with the degree of hazard at a user premises, as specified in this Chapter and as determined based on the results of the hazard assessment conducted pursuant to CCCPH [section 3.2.1](#).

(c) Unless specified otherwise in this Chapter, a PWS must, at all times, protect its distribution system from high hazard cross-connections (see [Appendix D for examples](#)), through premises containment, through the use of an AG or through the use of one or more RPs.

(1) Following State Water Board review and approval, a PWS may implement an alternate method of premises containment in lieu of a required AG provided that the proposed alternative would provide at least the same level of protection to public health.

(2) Following State Water Board review and approval, a PWS may accept internal protection in lieu of containment when premises containment is not feasible.

(d) Except as otherwise allowed or prohibited in statute or in CCR Title 22, Division 4, Chapter 3, a swivel-ell may be used instead of an AG for premises containment protection when temporarily substituting tertiary recycled water use areas with potable water from a PWS if all the following criteria are met:

- (1) the swivel-ell is approved by the State Water Board;
- (2) the PWS has a cross-connection control program, required pursuant to CCCPH section 3.1.3, and the use and operation of the swivel-ell is described in the Cross-Connection Control Plan required pursuant to CCCPH [section 3.1.4](#);
- (3) the design and construction-related requirements of the swivel-ell adheres to the criteria in [Appendix C](#);
- (4) at least every 12 months, inspections are performed and documented confirming ongoing compliance with the design and construction-related requirements in Appendix C;
- (5) the RP used in conjunction with the swivel-ell is field tested and found to be functioning properly:

- (A) immediately upon each switchover to potable water use a visual inspection of the device be completed
- (B) within 72 hours of each switchover to potable water use a field test is completed, and
- (C) at least every 12 weeks that the use site is being supplied with potable water; and

(6) there is a legally binding agreement between the PWS and the entity supplying the recycled water, signed by those with relevant legal authority, that includes the following requirements:

- (A) The State Water Board will be notified within 24 hours of all switchovers to or from potable water, will be given an estimate of the timeframe until the next switchover, and will be provided the results of the field testing required in paragraph (5);
- (B) a representative of the PWS be present to supervise each switchover; and
- (C) within seven days of each switchover, if requested by the State Water Board, the PWS will submit a written report describing compliance with this subsection, as well as potable and recycled water usage information.

(e) Except as noted below, a PWS must ensure its distribution system is protected with no less than DC protection for a user premise with a fire protection system within ten years of adoption of the CCCPH.

- (1) A high hazard cross-connection fire protection system, including but not limited to fire protection systems that may utilize chemical addition (e.g., wetting agents, foam, anti-freeze, corrosion inhibitor, etc.) or an auxiliary water supply, must have no less than RP protection.
- (2) For existing fire protection systems that do not serve a single-family residential connection and cannot install DC protection within ten years of

adoption of the CCCPH, a PWS may propose in the cross-connection control plan submitted for CCCPH Section 3.1.4:

- (A) an alternative date; or
 - (B) an alternative method of backflow protection that provides at least the same level of protection to public health.
- (3) A BPA is not necessary for a low hazard fire protection system on a residential user premise if the following criteria are satisfied:

- (A) the user premises has only one service connection to the PWS;
- (B) a single service line onto the user premises exists that subsequently splits on the property for domestic flow and fire protection system flow, such that the fire protection system may be isolated from the rest of the user premises;
- (C) a single, water industry standard, water meter is provided to measure combined domestic flow and fire protection system flow;
- (D) the fire protection system is constructed of piping materials certified as meeting NSF/ANSI Standard 61; and
- (E) the fire protection system's piping is looped within the structure and is connected to one or more routinely used fixtures (such as a water closet) to prevent stagnant water.

(f) The State Water Board, and PWS may, at their discretion, require a water user to designate a user supervisor when the user premises has a multi-piping system that conveys various types of fluids and where changes in the piping system are frequently made. If a user supervisor is designated the following is required:

- (1) The user supervisor will be responsible for the avoidance of cross-connections during the installation, operation and maintenance of the water user's pipelines and equipment. The user supervisor will be trained on the fluids used and backflow protection for the premise, must inform the PWS of changes in piping, and maintain current contact information on file with the PWS; and
- (2) the PWS will include in the Cross-Connection Control Plan required in CCCPH section 3.1.4 training and qualification requirements for user supervisors, identify the entity that will provide the user supervisor training, and frequency of any necessary recurring training. The training must adequately address the types of hazards and concerns typically found.

(g) Facilities producing, treating, storing, or distributing drinking water that are an approved water supply or water recycling plants as defined by CCR Title 22, Section 60301.710 must have proper internal protection from cross-connections to ensure that all drinking water or recycled water produced and delivered to customers and workers at those facilities is free from unprotected cross-connections.

Article 3 – Backflow Prevention Assemblies

3.3.1 Standards for Types of Backflow Protection

(a) The PWS must ensure that each AG meets the requirements in Table 1, Minimum Air Gaps for Generally used Plumbing Fixtures, page 4 of ASME A112.1.2-2012(R2017) (See Appendix B).

(b) The PWS must ensure that each replaced or newly installed PVB, SVB, DC, and RP for protection of the PWS is approved through both laboratory and field evaluation tests performed in accordance with at least one of the following:

- (1) Standards found in the Tenth edition of the Foundation for Cross-Connection Control and Hydraulic Research of the University of Southern California Manual of Cross-Connection Control;
- (2) certification requirements for BPAs in the Standards of ASSE International current as of 2020; or
- (3) a testing process with equivalent testing requirements to (1) or (2).

(c) BPAs must not be modified following approval granted under section 3.3.1 (b). PWS must require BPA testers to notify the PWS if a water user or PWS-owned BPA has been modified from the CCCPH section 3.3.1 (b) approval.

3.3.2 Installation Criteria for Backflow Protection

(a) For AGs, the following is required:

- (1) The receiving water container must be located on the water user's premises at the water user's service connection unless an alternate location has been approved by the PWS;
- (2) all piping between the water user's service connection and the discharge location of the receiving water container must be above finished grade and be accessible for visual inspection unless an alternative piping configuration is approved by the PWS;
- (3) the PWS must ensure that the AG specified in CCCPH section 3.3.1 (a) has been installed; and
- (4) any new air gap installation at a user service connection must be reviewed and approved by the State Water Board prior to installation.

(b) RPs must be installed such that the lowest point of an assembly is a minimum of twelve inches above grade, and, a maximum of thirty-six inches above the finished grade, unless an alternative is approved by the PWS.

(c) DCs installed or replaced after the adoption of the CCCPH must be installed according to CCCPH section 3.3.2 (b). Below ground installation can be considered if approved by the PWS where it determines no alternative options are available.

(d) A PVB or SVB must be installed a minimum of twelve inches above all downstream piping and outlets.

(e) SVBs may not be used for premises containment. PVBs may not be used for premises containment except where there is no potential for backpressure, such as roadway right of way irrigation systems.

(f) A RP or DC installed after the adoption of the CCCPH must have a minimum side clearance of twelve inches, except that a minimum side clearance of twenty-four inches must be provided on the side of the assembly that contains the test cocks. The PWS may approve alternate clearances providing that there is adequate clearance for field testing and maintenance.

(g) Backflow protection must be located as close as practical to the water user's service connection unless one or more alternative locations have been approved by the PWS. If internal protection is provided for the purpose of containment, the PWS must obtain access to the user premises and must ensure that the on-site protection meets the requirements of this Chapter for installation, field testing and inspections.

(h) Each BPA and air gap separation must be accessible for field testing, inspection, and maintenance.

3.3.3 Field Testing and Repair of Backflow Prevention Assemblies and Air Gap Inspection

(a) PWS must ensure that all BPAs installed are field tested following installation, repair, depressurization for winterizing, or permanent relocation. All required field testing must be performed by a certified backflow prevention assembly testers.

(b) BPAs must be field tested at least annually. The CCCPH does not preclude a PWS, the State Water Board, or a local health agency from requiring more frequent field testing.

(c) Air-gap separations must be visually inspected at least annually to determine compliance with this Chapter by persons certified as backflow prevention assembly testers or certified as a cross-connection control specialist pursuant to this Chapter.

(d) PWS must receive passing field tests before providing service to a water user with a newly installed BPA.

(e) PWS must ensure that BPAs that fail the field test are repaired or replaced within 30 days of notification of the failure. Extensions may be allowed by the PWS if included as part of CCC Plan.

(f) PWS must require backflow prevention assembly testers to notify the PWS within one day if a backflow incident or cross-connection is observed during field testing. PWS must immediately conduct an investigation and discontinue service to the user premises if a backflow incident is confirmed, and water service must not be restored to that user premises until the PWS receives a confirmation of a passing BPA field test from a backflow prevention assembly tester and the assembly is protecting the PWS.

Article 4 – Backflow Prevention Assembly Testers and Cross-Connection Control Specialists

3.4.1 Backflow Prevention Assembly Tester Certification

(a) A PWS must ensure that each BPA required by this Chapter to protect the public water system is field tested by a person with valid certification from a certifying organization recognized by the State Water Board pursuant to this Article.

(b) A State Water Board-recognized organization certifying backflow prevention assembly testers is one that has a certification process that, at a minimum, includes the following:

(1) A timed and proctored written⁶ exam, using a closed-book, objective grading format, consisting of no less than 100 questions for initial certification and no less than 50 questions for recertification. A passing score must be achieved by an examinee as a requirement for certification.

(A) Written exam proctors must:

1. not provide an examinee any assistance in answering exam questions, verbal or otherwise; and
2. be impartial.

(B) Passing scores for the written exams are to be determined prior to exam sessions, such that passing a written exam demonstrates sufficient knowledge of subjects associated with the proper field testing of BPAs, including but not limited to:

1. The hydraulics and theory of backflow;
2. California's laws, regulations, and requirements related to cross-connection control;
3. types of BPA field test equipment and the need to verify accuracy, at least annually and when otherwise necessary, to ensure accuracy of field test results;
4. field test procedures for an RP, RPDA, RPDA-II, DC, DCDA, DCDA-II, PVB, and SVB using the procedures provided in the University of Southern California Foundation for Cross-Connection Control and Hydraulic Research's *Manual of Cross-Connection Control, Tenth Edition* or equivalent;
5. identification of improperly functioning BPAs (i.e., diagnostics or troubleshooting); and
6. recordkeeping and safety.

⁶ The requirement for a written exam does not preclude using computerized exams.

(2) a performance (i.e., hands-on) exam, using a closed-book, objective grading process and the field test procedures in paragraph (1)(B)(4), designed such that passing the performance exam demonstrates proficiency in accurately determining the operating condition of an RP, DC, PVB, and SVB, when properly or improperly functioning, including but not limited to BPAs with failures in shutoff valves, check valves, air inlet valves, or relief valves. A passing score must be achieved by an examinee as a requisite for certification. The performance exam process must include the following:

(A) Performance exam proctors must:

1. be certified as a backflow prevention assembly tester pursuant to this Article;
2. evaluate no more than one examinee at a time;
3. not provide an examinee any assistance in answering exam questions, verbal or otherwise;
4. provide no indication an examinee has erred until completion of a BPA field test, at which time only the fact the examinee has erred may be indicated (i.e., not the nature of the error);
5. be impartial and not affiliated with the certifying organization's preparation of, or preparatory course for (if applicable), the performance exam; and
6. not evaluate an examinee who was trained by the proctor during the six-month period prior to the exam or other conflict of interest.

(B) An examinee is considered to have failed a performance exam if:

1. the examinee makes a field test procedure or recording error that could impact an accurate determination of the operating condition of a BPA,
2. completes the BPA performance exam form with an error,
3. is informed of making an error (see subparagraph (A)(4)) and begins the procedure a second time, and
4. errs a second time and completes the BPA performance exam form accordingly.

(3) requires recertification no less frequently than every three years which includes both a written and performance exam;

(4) provisions for revocation of a backflow prevention assembly tester's certification, including but not limited to, revocation for falsifying field test results or field test reports;

(5) a website providing public access to the most recent list of backflow prevention assembly testers:

(A) who hold a valid certification from the certifying organization. At a minimum, the list is to include each backflow prevention assembly tester's

last name, first name, certification number, and the date on which each backflow prevention assembly tester's certification expires; and (B) whose certification was revoked, pursuant to paragraph (4), in the three years preceding the date of the list. At a minimum, the list is to include each backflow prevention assembly tester's last name, first name, revoked certification number, the date on which each backflow prevention assembly tester's certification was revoked, and the reason for revocation.

(6) as a requisite, two years prior experience as a backflow prevention assembly tester, or completion of an instructional training course accepted by the certifying organization⁷ that covers the subjects in subsection (1)(B) and is no less than 30 hours in length over no fewer than four days for:

- (A) a backflow prevention assembly tester's initial certification;
- (B) a backflow prevention assembly tester's recertification as a result of revocation; or
- (C) when an examinee has not held a valid certification for three or more years.

(c) To be recognized by the State Water Board as a certifying organization for backflow prevention assembly testers, a certifying organization shall submit an application with the information in paragraphs (1) through (3) below to the State Water Board for review, adequately address each State Water Board comment and/or question concerning the application, and receive written acknowledgment from the State Water Board that the application is complete:

- (1) Written documentation of a certification program that includes a process that is no less stringent than the criteria in subsection (b);
- (2) evidence that the organization's certification program and exam process has been reviewed, with concerns adequately addressed, by a credentialed psychometrician proficient in the design of objective exams, experienced in the assessment of certification or licensing organizations, and familiar with the application of the requirements of *ISO⁸/IEC⁹ 17024: Conformity Assessment- General Requirements for Bodies Operating Certification of Persons*; and
- 3) a written statement, signed by the certifying organization's representative(s) having the authority and legal responsibility for operation of the certifying organization, attesting that the certifying organization will implement its certification program in a manner meeting or exceeding the criteria in subsection (b) and consistent with the application submitted to the State Water Board.

(d) An American National Standards Institute (ANSI)-accredited certifying organization, accredited in accordance with subsection (b) and ISO/IEC 17024, will be considered to be a State Water Board-recognized certifying organization. Beginning three years after

⁷ But not limited only to training provided by the certifying organization or its affiliates.

⁸ International Organization for Standardization

⁹ International Electrotechnical Commission

the effective date of the CCCPH, only those testers with a valid certification from an ANSI-accredited certifying organization shall satisfy subsection (a) and certifications obtained in accordance with subsection (c) will be invalid.

(e) This Article does not preclude a local health agency (e.g., county) from maintaining a backflow prevention assembly tester certification program for the field testing of BPAs within the local health agency's jurisdiction. Accepting a tester certified by a local health agency does not relieve a PWS from meeting the requirements of this Article.

(f) This Article does not preclude a PWS from disallowing an individual tester certified pursuant to this Article if the PWS has reason to believe a certified tester may not be proficient in accurately determining the operating condition of BPA, or for any other reason (e.g., fraud, deceit, negligence, misconduct, etc.).

(g) This Article is effective *[insert date twelve months after effective date of the handbook]*.

3.4.2 Cross-Connection Control Specialist Certification

(a) A PWS must ensure that cross-connection control specialists, used pursuant to this Article, have valid certification from a certifying organization recognized by the State Water Board pursuant to this Article.

(b) A State Water Board-recognized organization certifying cross-connection control specialists is one that has a certification process that, at a minimum, includes the following:

(1) A timed and proctored, written¹⁰ exam, using a closed-book, objective grading format, consisting of no less than 100 questions for certification. A passing score must be achieved by an examinee as a requirement for certification.

(A) Written exam proctors must:

1. not provide an examinee any assistance in answering exam questions, verbal or otherwise; and
2. be impartial.

(B) Passing scores for the exams are to be determined prior to exam sessions, such that passing an exam demonstrates sufficient and comprehensive range of knowledge of the subjects provided in [Appendix E](#), as they may relate to cross-connection control and the causes, effects, and prevention of backflow.

(2) require recertification no less frequently than every three years.

Recertification may be done through

(A) an exam as required by section 3.4.2 (b)(1),

(B) through 12 hours of continuing education contact hours from training courses covering material in [Appendix E](#) or,

(C) a combination of exam and continuing education contact hours

(3) provisions for revocation of a specialist's certification, including but not limited to, falsifying information or providing negligent recommendations inconsistent with industry-standard cross-connection control guidelines;

(4) a website providing public access to the most recent list of cross-connection control specialists:

(A) who hold a valid certification from the certifying organization. At a minimum, the list is to include each specialist's last name, first name, certification number, and the date on which each specialist's certification expires; or

(B) whose certification was revoked, pursuant paragraph (3), in the three years preceding the date of the list. At a minimum, the list is to include each specialist's last name, first name, revoked certification number, the

¹⁰ The requirement for a written exam does not preclude using computerized exams.

date on which each specialist's certification was revoked, and the reason for revocation.

(5) for initial certification or when an examinee has not held a valid certification for three or more years from a certifying organization recognized pursuant to this Article, requires:

(A) a valid backflow prevention assembly tester certification from a certification organization recognized by the State Water Board pursuant to CCCPH section 3.4.1; and

(B) completion of an instructional training course (acceptable to the certifying organization¹¹) that covers the subjects in **Appendix E** and is no less than 30 hours in length over no fewer than five days (inclusive of an exam, if provided). This paragraph does not preclude a certification organization from providing the instructional training course to the public, including certified specialists.

(C) As an alternative to (A) the certifying organization may require additional instruction in the subject areas of testing, maintaining and repairing BPAs equivalent in length and scope to the requirements in 3.4.1(b)(6).

(D) As an alternative to (A) the certifying organization may accept a minimum of five (5) years documented experience performing cross-connection control specialist duties, as outlined in Appendix E

(c) To be recognized by the State Water Board as a certifying organization for cross-connection control specialists, a certifying organization shall submit an application with the information in paragraphs (1) through (3) below to the State Water Board for review, adequately address each State Water Board comment and question concerning the application, and receive a written acknowledgment from the State Water Board that the application is complete:

(1) Written documentation of a certification program that includes a process that is no less stringent than the criteria in subsection (b);

(2) evidence that the organization's certification program and exam process has been reviewed, with concerns adequately addressed, by a credentialed psychometrician proficient in the design of objective exams, experienced in the assessment of certification or licensing organizations, and familiar with the application of the requirements of *ISO¹²/IEC¹³ 17024: Conformity Assessment-General Requirements for Bodies Operating Certification of Persons*; and

(3) a written statement, signed by the certifying organization's representative(s) having the authority and legal responsibility for operation of the certifying organization, attesting that the certifying organization will implement its

¹¹ But not limited only to training provided by the certifying organization or its affiliates.

¹² International Organization for Standardization

¹³ International Electrotechnical Commission

certification program in a manner meeting or exceeding the criteria in subsection (b) and consistent with the application submitted to the State Water Board.

(d) A certifying organization, accredited by the American National Standards Institute (ANSI) in accordance with ISO/IEC 17024, which complies with subsection (b), will be considered to be a State Water Board-recognized certifying organization. Beginning three years after adoption of the CCCPH, only those specialists with a valid certification from an ANSI-accredited certifying organization shall satisfy subsection (a) and certifications obtained in accordance with subsection (c) will be invalid.

(e) This Article does not preclude a local health agency (e.g., county) from maintaining a cross-connection control specialist certification program for specialists within the local health agency's jurisdiction. Using a specialist certified by a local health agency does not relieve a PWS from meeting the requirements of this Article.

(f) This Article does not preclude a PWS from disallowing an individual cross-connection control specialist certified pursuant to this Article if the PWS has reason to believe a certified specialist may not be proficient in their knowledge of cross-connection control and the causes, effects, and prevention of backflow, or for any other reason (e.g., fraud, deceit, negligence, misconduct, etc.).

(g) This Article is effective *[insert date twelve months after effective date of the handbook]*.

Article 5 – Recordkeeping, Backflow Incident Response, and Notification

3.5.1 Recordkeeping

(a) Each PWS must maintain at a minimum the following records:

- (1) The two most recent hazard assessments for each user premise, conducted pursuant to CCCPH section 3.2.1 (Hazard Assessment);
- (2) for each BPA, the associated hazard or application, location, owner, type, manufacturer and model, size, installation date, and serial number;
- (3) for each AG installation the associated hazard or application and the location, owner, and as-built plans of the AG;
- (4) results of all BPA field testing and AG and swivel-ell inspections for the previous three calendar years, including the name, test date, repair date, and certification number of the backflow prevention assembly tester for each BPA field test and AG and swivel-ell;
- (5) repairs made to, or replacement or relocation of, BPAs for the previous three calendar years;
- (6) the most current cross-connection tests (e.g. shutdown test, dye test);
- (7) if a user supervisor is designated for a user premise, the current contact information for the user supervisor and water user, and any applicable training and qualifications as described by CCCPH section 3.2.2(f);
- (8) descriptions and follow-up actions related to all backflow incidents;
- (9) if any portion of the cross-connection control program is carried out under contract or agreement, a copy of the current contract or agreement; and
- (10) the current Cross-Connection Control Plan as required in CCCPH section 3.1.4.
- (11) any public outreach or education materials issued as required in CCCPH section 3.1.3.(a)(9) for the previous three calendar years

(b) All information in subsection (a) must be available to the State Water Board upon request.

3.5.2 Backflow Incident Response Procedure

Each PWS must include backflow incident response procedures in the Cross-Connection Control Plan required in CCCPH section 3.1.4. The PWS must describe its procedures for investigating and responding to suspected backflow incidents including, but not limited to, the following:

(a) Consideration of complaints or reports of changes in water quality as possible incidents of backflow;

(b) Water quality sampling and pressure recording; and

(c) Documentation of the investigation, and any response and follow-up activities.

3.5.3 Backflow Incident Notification

(a) Each PWS must notify the State Water Board of any known incident of backflow within 24 hours of the determination. If required by the State Water Board, a PWS must issue a Tier 1 public notification pursuant to CCR, Title 22, Section 64463.1.

(b) If required by the State Water Board, the PWS must submit, by a date specified by the State Water Board, a written incident report describing the details and affected area of the backflow incident, the actions taken by the PWS in response to the backflow incident, and the follow up actions to prevent future backflow incidents. The written report must contain, at a minimum, the information requested in [Appendix F](#).

This page intentionally left blank

Appendix

Appendix A: Assembly Bill 1671 (2017, Chapter 533) and Assembly Bill 1180 (2019, Chapter 455).

Appendix B: ASME A112.1.2-2012(R2017) Table 1, Minimum Air Gaps for Generally used Plumbing Fixtures, page 4

Appendix C: Backflow Prevention Assembly diagrams.

Appendix D: High Hazard Premises

Appendix E: General Range of Knowledge - Cross-Connection Control Specialist.

Appendix F: Example Backflow Incident Reporting Form

Appendix G: Related Statutes and Regulations

This page intentionally left blank

Appendix A

Assembly Bill 1671 (2017, Chapter 533)
Assembly Bill 1180 (2019, Chapter 455)

This page intentionally left blank

PLACEHOLDER – ADD PDFs HERE OF AB 1671 (3 PAGES) AND AB 1180 (3 PAGES) AND DELETE THIS PAGE. NEXT PAGE INTENTIONALLY BLANK.

This page intentionally left blank

Appendix B

ASME A112.1.2-2012(R2017) Table 1,
Minimum Air Gaps for Generally used Plumbing
Fixtures, page 4

This page intentionally left blank

Appendix B
ASME A112.1.2-2012(R2017) Table 1, Minimum Air Gaps for Generally used Plumbing Fixtures, page 4

TABLE 1
Minimum Air Gaps for Generally used Plumbing Fixtures⁴

FIXTURES	WHERE NOT AFFECTED BY SIDEWALLS ¹ (inches)	WHERE AFFECTED BY SIDEWALLS ² (inches)
Effective opening ³ not greater than ½ of an inch in diameter	1	1½
Effective openings ³ not greater than ¾ of an inch in diameter	1½	2¼
Effective openings ³ not greater than 1 inch in diameter	2	3
Effective openings ³ greater than 1 inch in diameter	Two times the diameter of effective opening	Three times the diameter of effective opening

For SI units: 1 inch = 25.4 mm

Notes:

¹ Sidewalls, ribs, or similar obstructions do not affect air gaps where spaced from the inside edge of the spout opening a distance exceeding three times the diameter of the effective opening for a single wall, or a distance exceeding four times the effective opening for two intersecting walls.

² Vertical walls, ribs, or similar obstructions extending from the water surface to or above the horizontal plane of the spout opening other than specified in Footnote 1 above. The effect of three or more such vertical walls or ribs has not been determined. In such cases, the air gap shall be measured from the top of the wall.

³ The effective opening shall be the minimum cross-sectional area at the seat of the control valve or the supply pipe or tubing that feeds the device or outlet. Where two or more lines supply one outlet, the effective opening shall be the sum of the cross-sectional areas of the individual supply lines or the area of the single outlet, whichever is smaller.

⁴ Air gaps less than 1 inch (25.4 mm) shall be approved as a permanent part of a listed assembly that has been tested under actual backflow conditions with vacuums of 0 to 25 inches of mercury (85 kPa).

This page intentionally left blank

Appendix C

Backflow Prevention Assembly Diagrams

This page intentionally left blank

Appendix C

Diagram 1

Double check detector backflow prevention assembly¹

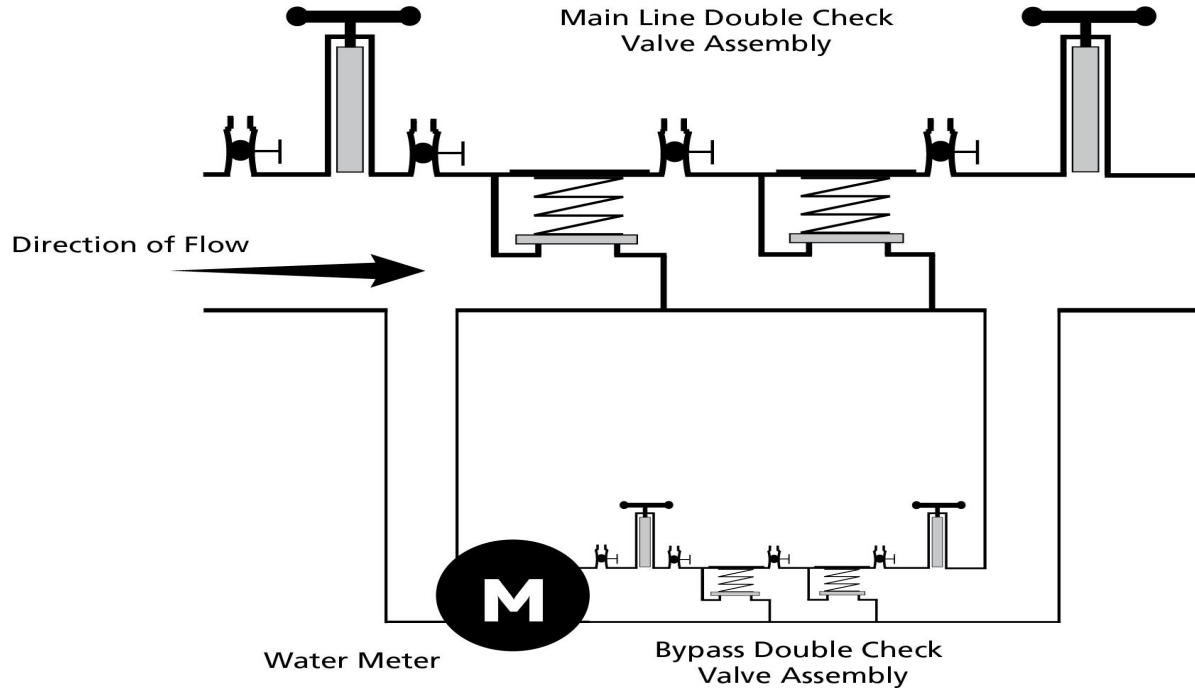

¹ Diagram © University of Southern California, used with permission.

Appendix C

Diagram 2

*Double check detector backflow prevention assembly – type II*²

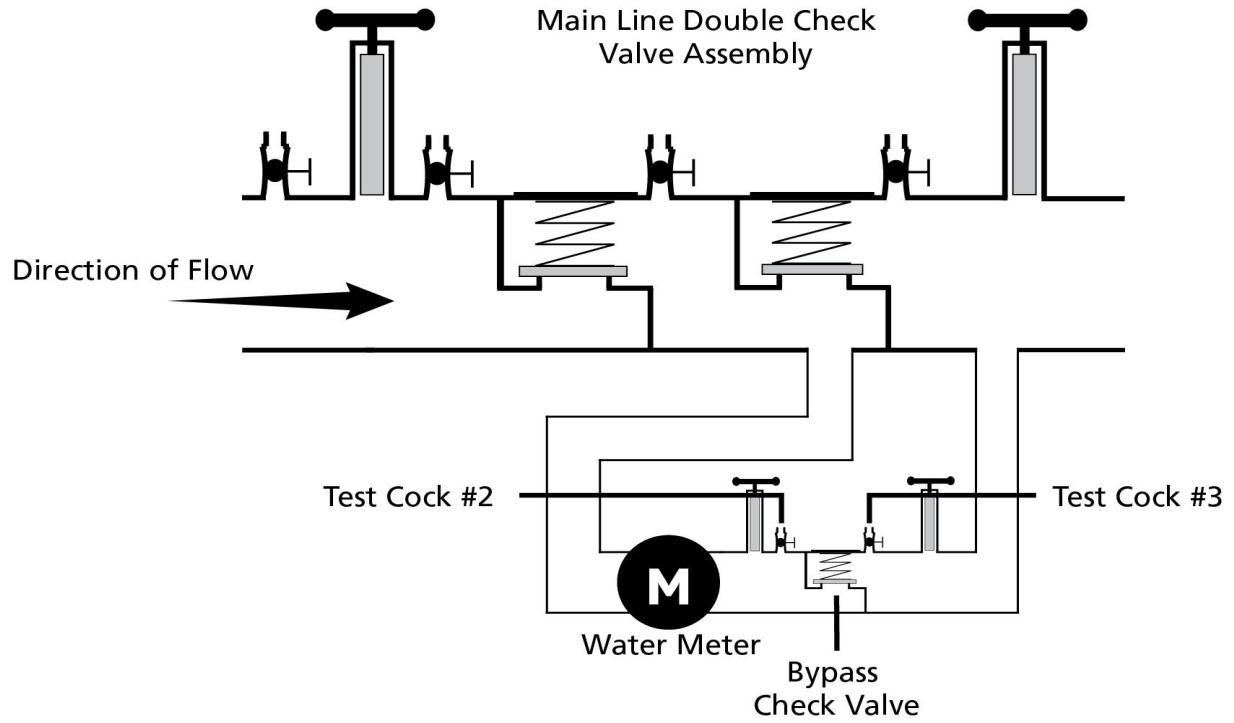

² Diagram © University of Southern California, used with permission.

Appendix C

Diagram 3
*Double check valve backflow prevention assembly*³

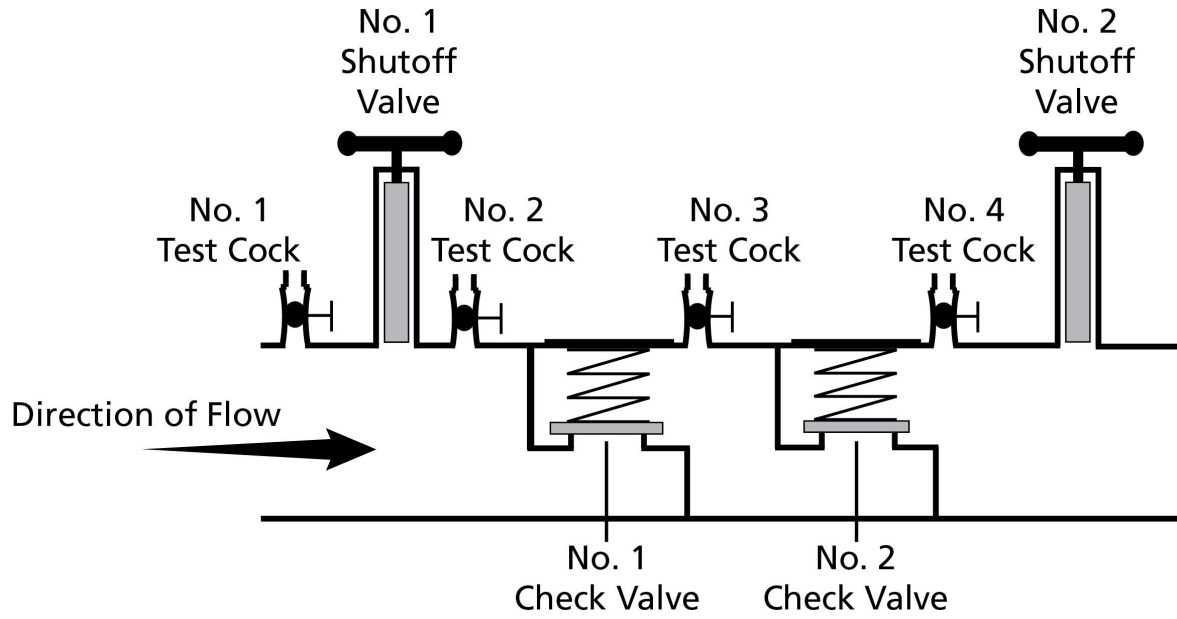

³ © University of Southern California, used with permission

Appendix C

Diagram 4

*Pressure vacuum breaker backsiphonage prevention assembly*⁴

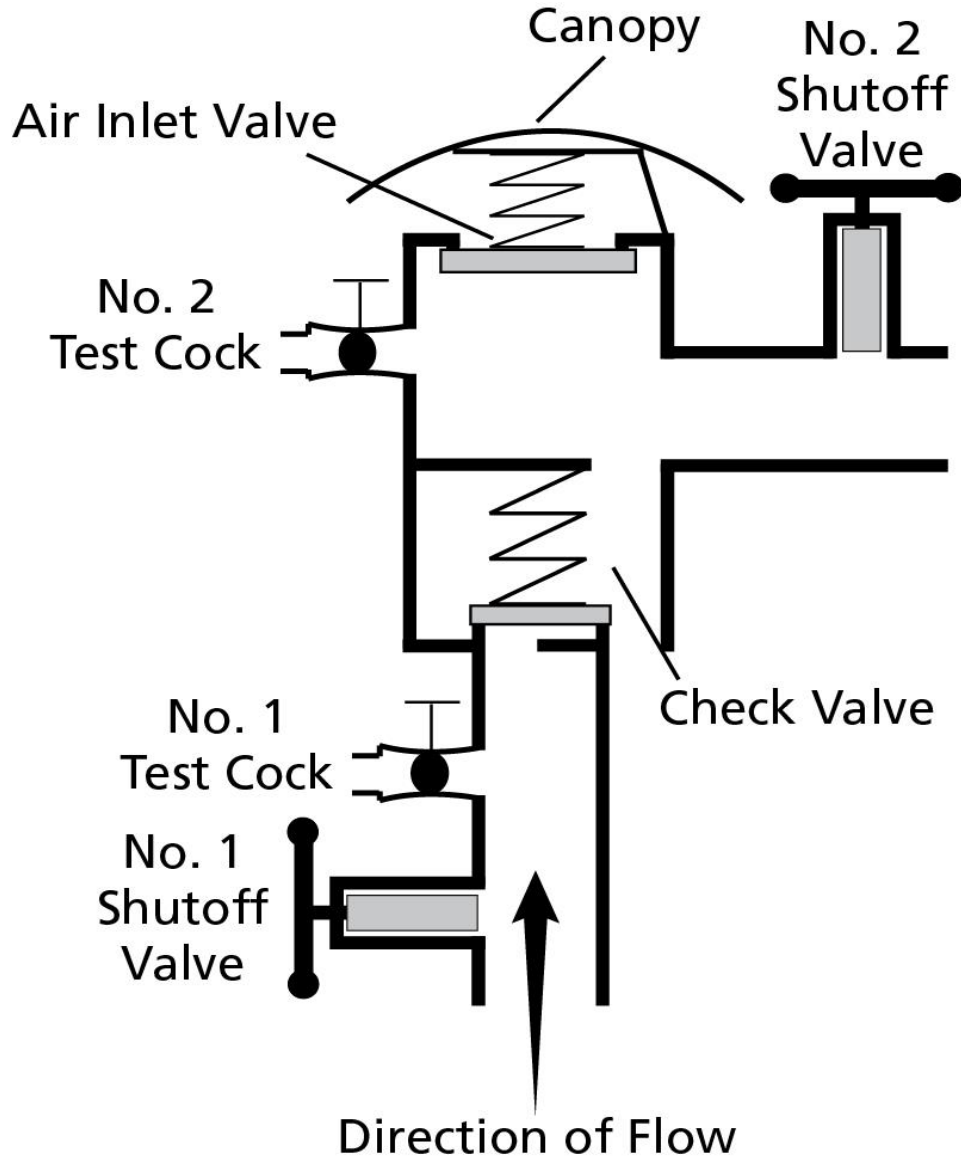

⁴ © University of Southern California, used with permission

Appendix C

Diagram 5
*Reduced pressure principle backflow prevention assembly*⁵

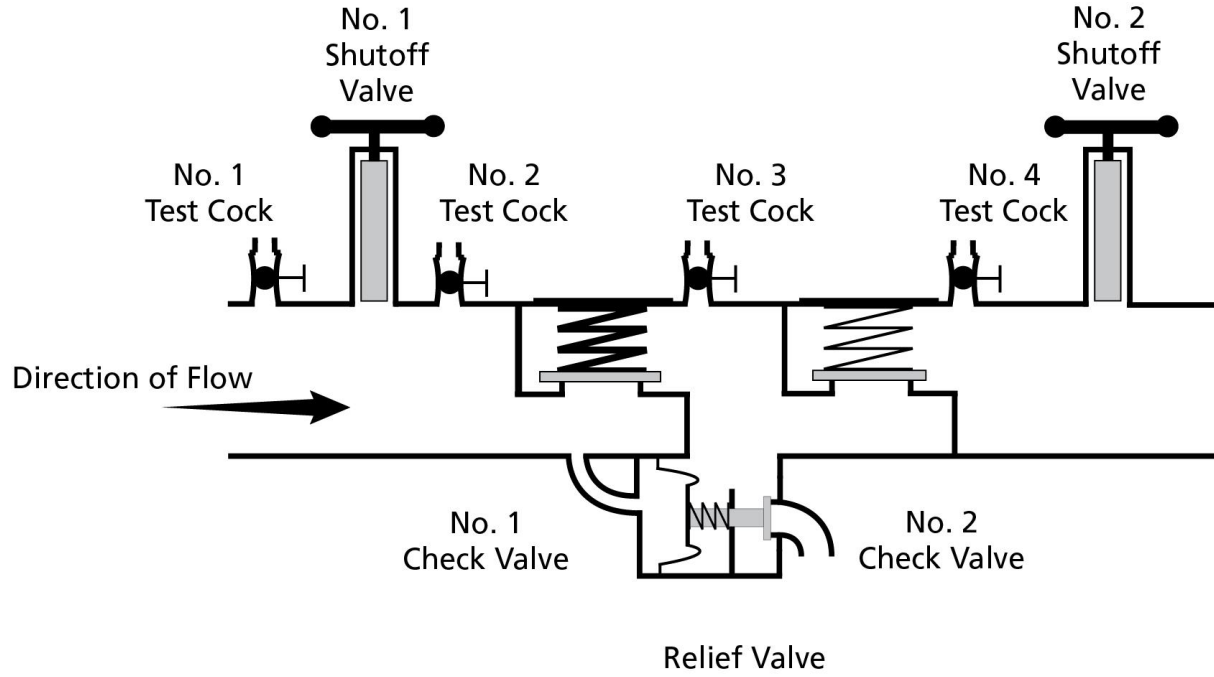

⁵ © University of Southern California, used with permission

Appendix C

Diagram 6

Reduced pressure principle detector backflow prevention assembly⁶

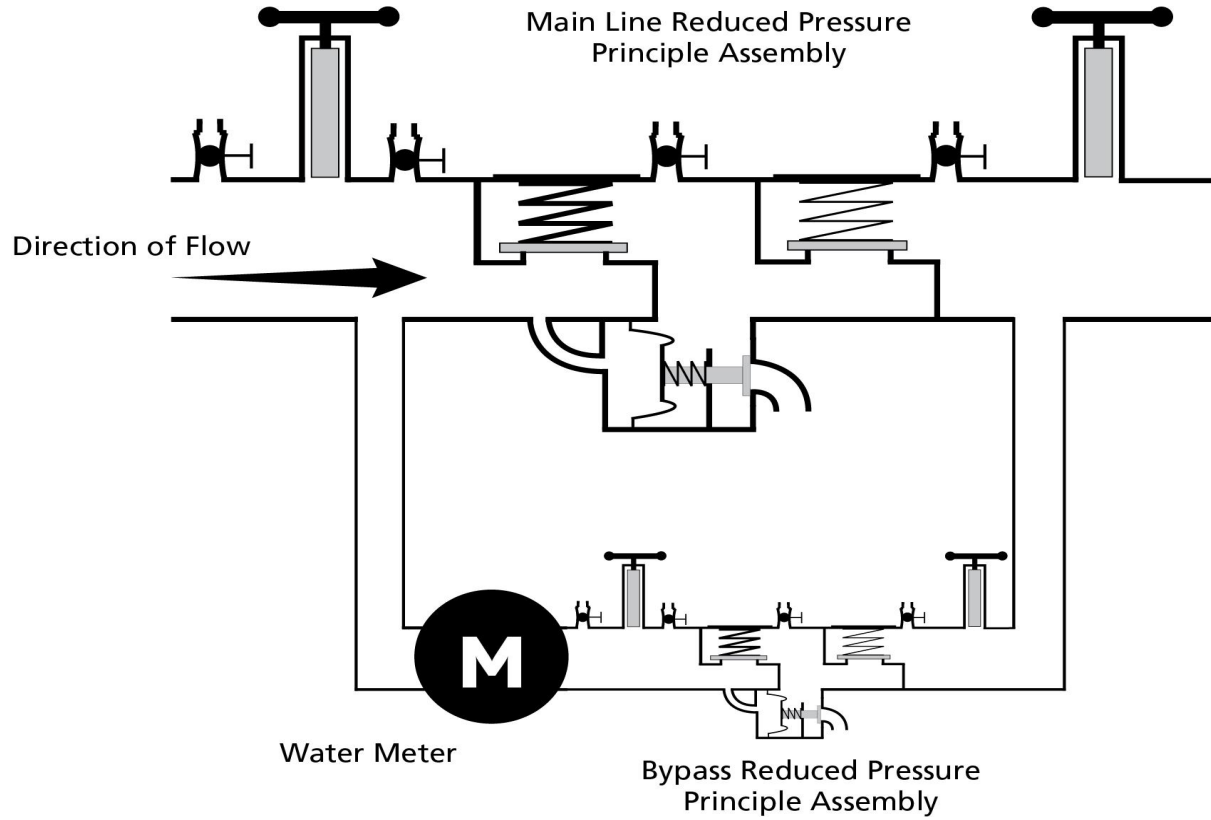

⁶ © University of Southern California, used with permission

Appendix C

Diagram 7

Reduced pressure principle detector backflow prevention assembly – type II⁷

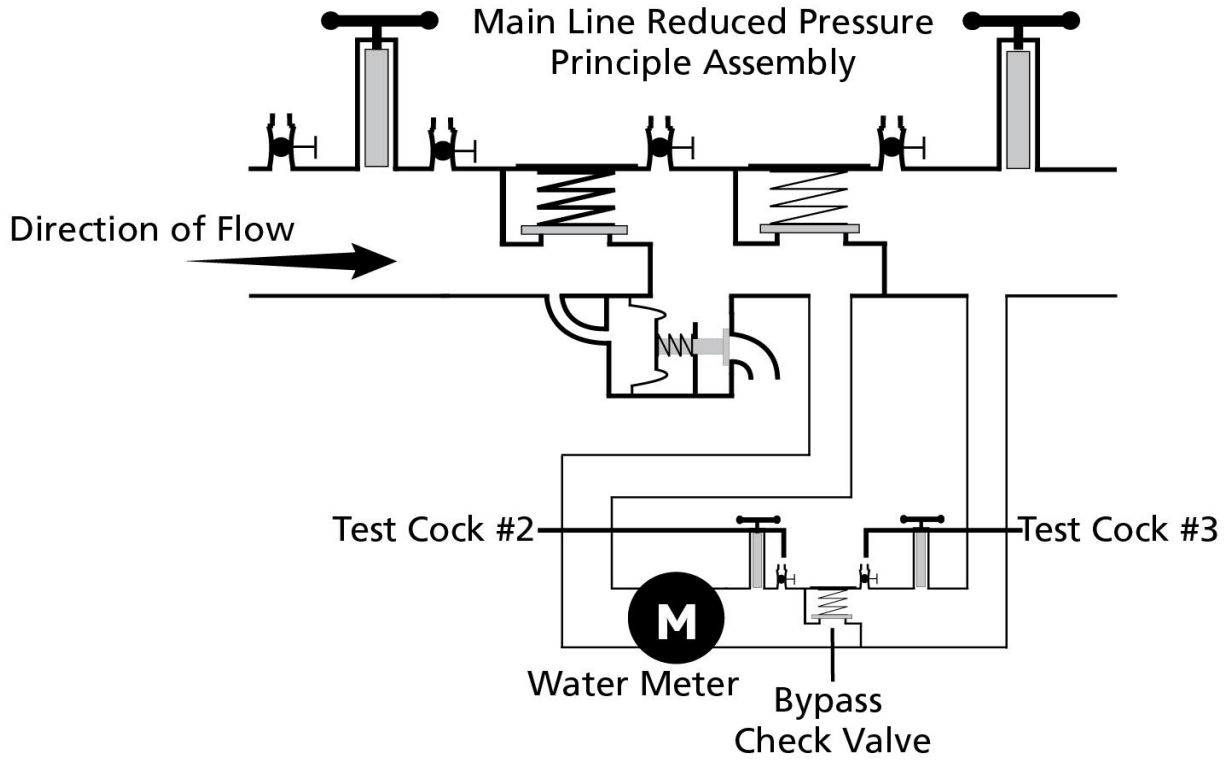

⁷ © University of Southern California, used with permission

Appendix C

Diagram 8

*Spill-resistant pressure vacuum breaker backsiphonage prevention assembly*⁸

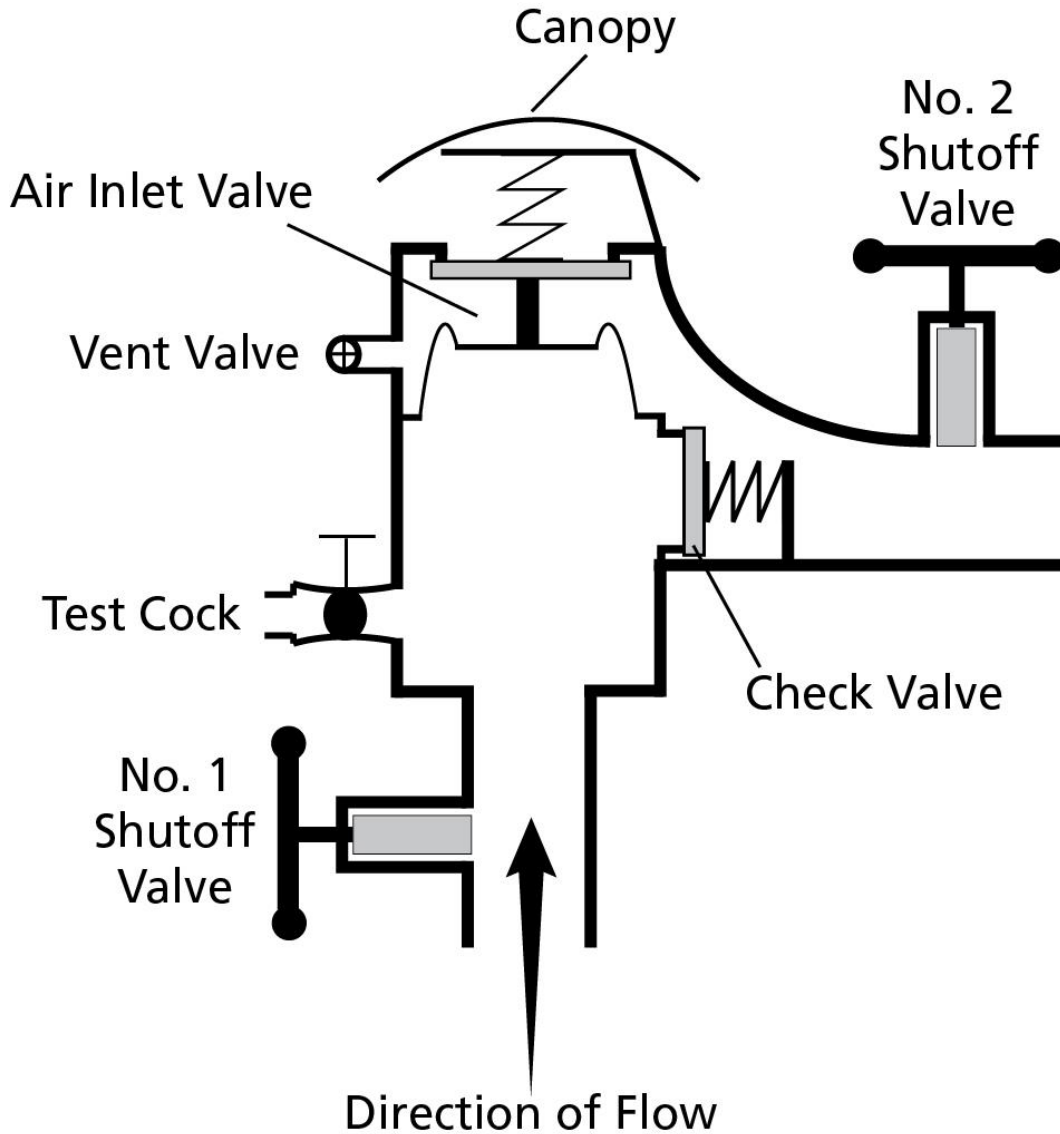

⁸ © University of Southern California, used with permission

Appendix C

Swivel-Ell Design and Construction Criteria

The criteria below, in conjunction with the swivel-ell diagrams that follow (Diagrams 9a and 9b), are **minimum** acceptable design and construction-related requirements for utilizing a swivel-ell. For restrictions and allowances for utilizing a swivel-ell, see CCCPH section 3.2.2.

A. Prior to operation of a swivel-ell, the PWS will receive approval for the design and construction plans of that swivel-ell from the State Water Board.

]B. The drinking water supply must not, under any circumstances, be directly connected to the recycled water supply, nor be designed such that the recycled water use site could be supplied concurrently by a recycled water supply and a drinking water supply.

C. The drinking water supply line and the recycled water supply line must be offset (see Diagram 9b) in a manner that ensures a tee-connection, spool, or other prefabricated mechanical appurtenance(s) could not be readily utilized in lieu of the swivel-ell connection, nor result in the recycled water use site being supplied concurrently by recycled water and drinking water.

D. The recycled water supply line used in conjunction with the swivel-ell must be the only recycled water supply to the recycled water use site.

E. The swivel-ell must be located as close as practical to the public water system service connection, with the swivel-ell connection being located as close as practical to the RP upstream of the swivel-ell.

F. The swivel-ell must:

1. be located above ground;
2. be color-coded pursuant to section 116815 of the CHSC and its implementing regulations;
3. include appropriate signage, as required by regulation and the State Water Board;
4. be provided the security necessary to prevent interconnections, vandalism, unauthorized entry, etc.; and
5. be provided with meters on both the recycled water service and drinking water service connections.

Diagram 9a: Example Swivel-Ell Pictorial (also see Plan View Schematics)

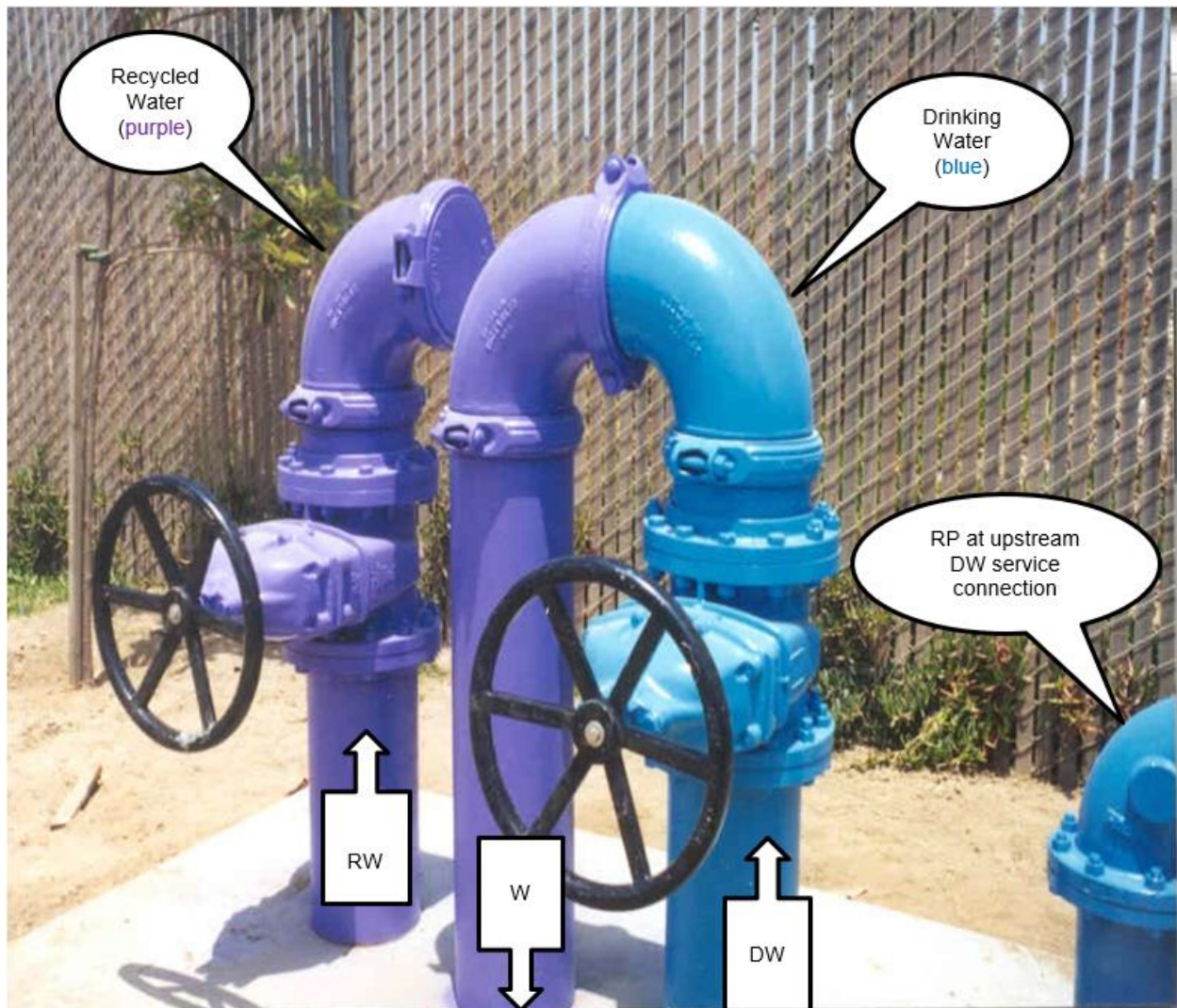

Legend (also see next page)

- RP = Reduced pressure principle backflow prevention assembly.
- RW = Tertiary-treated recycled water originating from wastewater treatment facility.
- DW = Drinking water originating from a public water system.
- W = Water (tertiary recycled water or drinking water) to use site. As pictured, configured for supplemental drinking water to the use site.
- M = Meter (*next page*)
- PE = Plain End (*next page*)
- GRV = Groove (*next page*)
- PWS = Public Water System (*next page*)

Note: The RP, a required component of an acceptable swivel-ell, is not shown in the picture.

**Diagram 9b: Swivel-Ell Typical Plan View Schematics
(not intended to be an exact portrayal of the pictorial)**

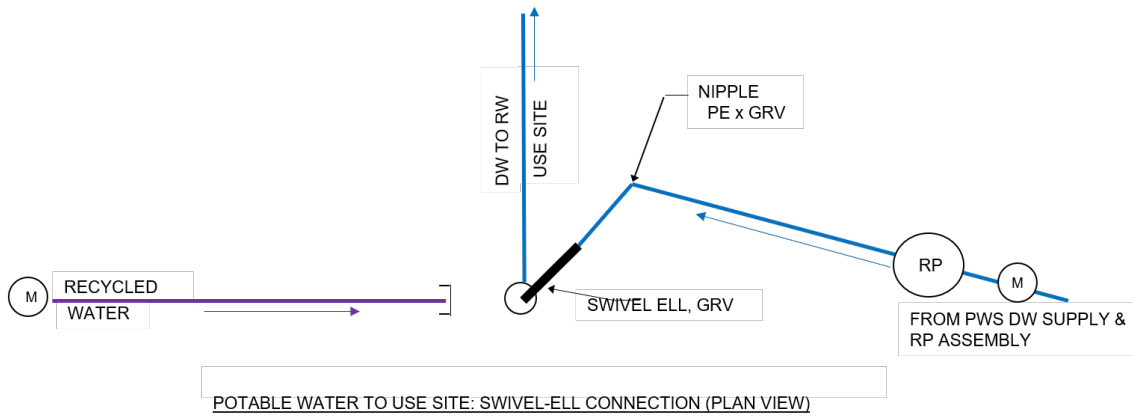
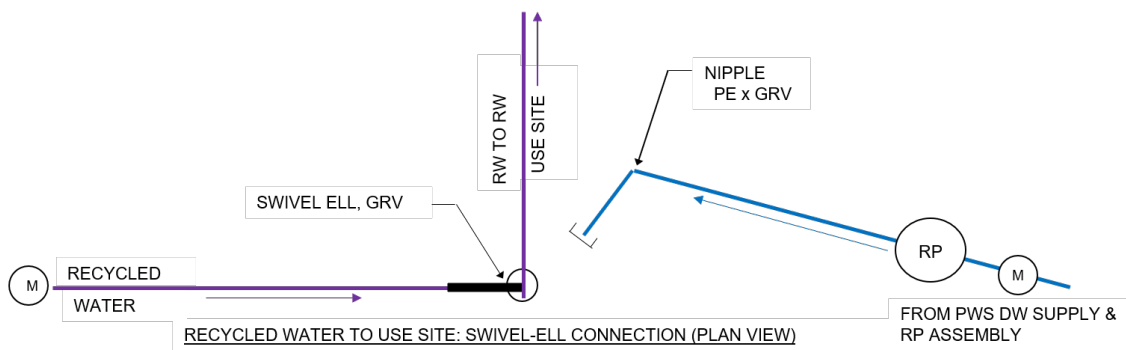

This page intentionally left blank

Appendix D

High Hazard Premises

This page intentionally left blank

APPENDIX D

HIGH HAZARD CROSS-CONNECTION CONTROL PREMISES

The list below identifies premises that require backflow protection provided by an air gap or a reduced pressure principle backflow prevention assembly, unless noted otherwise. The list below is not intended to be all-inclusive and a public water system may require an AG, RP, or both to protect a public water system from other hazards not listed below and identified in premises through the hazard assessment completed in CCCPH Chapter 3, section 3.2.1. A PWS may reduce or increase the minimum protection required for a previously hazard-assessed user premise following a hazard reassessment as described in CCCPH Chapter 3, section 3.2.1.

1. Sewage handling facilities
2. Wastewater lift stations and pumping stations
3. Wastewater treatment processes, handling, or pumping equipment that is interconnected to a piping system connected to a PWS (+)
4. Petroleum processing or storage plants
5. Radioactive material storage, processing plants or nuclear reactors
6. Mortuaries
7. Cemeteries
8. Sites with an auxiliary water supply interconnected with PWS (+)
9. Sites with an auxiliary water supply not interconnected with PWS
10. Premises with more than one connection to the PWS (++++)
11. Recycled water (++)(+++)
12. Recycled water interconnected to piping system that contains water received from a PWS (+)
13. Graywater systems, as defined in California Water Code Section 14876, that are interconnected to a piping system that is connected to a PWS
14. Medical facilities
15. Kidney dialysis facilities
16. Dental office with water-connected equipment
17. Veterinarian
18. Chemical plants
19. Laboratories
20. Biotech facilities
21. Electronics manufacture
22. Dry cleaner facilities
23. Industrial or commercial laundry facilities
24. Metal-plating facilities
25. Business park with a single meter serving multiple businesses
26. Marine-port facilities
27. Car wash facilities
28. Mobile home park, RV park, or campgrounds with RV hookups
29. Hotels/motels
30. Gas stations

31. Fire stations
32. Solid waste disposal facilities
33. Pet groomers
34. Agricultural premises
35. Hazard assessment access denied or restricted
36. Railroad maintenance facilities
37. Incarceration facilities (e.g. prisons)
38. Temporary connections to fire hydrants for miscellaneous uses, including construction
39. Private water distribution mains
40. Drinking water storage tank overflow connected to a sump or storm drain (+)
41. Airports

(+) Premise isolated by air gap only except as allowed through CCCPH Section 3.2.2 (c)

(++) Dual-plumbed use areas established per CCR Title 22, Section 60313 through 60316 where recycled water is used for individually owned residential unit.

(+++)
Residences using recycled water for landscape irrigation as part of an approved dual plumbed use area established pursuant to CCR Title 22, sections 60313 through 60316 shall use a DC, at a minimum, backflow prevention assembly. The recycled water supplier may obtain approval of the local public water supplier or the State Water Board, if the water supplier is also the supplier of the recycled water, to utilize an alternative backflow protection plan that includes an annual inspection of both the recycled water and potable water systems and an annual cross-connection test of the recycled water and potable water systems pursuant to subsection 60316(a) in lieu of any backflow prevention assembly.

(++++)
All connections must receive at least the same level of protection excluding fire protection when connected to the PWS distribution system (e.g. if one connection requires an RP then all connections must have RPs installed).

Appendix E

General Range of Knowledge for Cross-
Connection Control Specialists

This page intentionally left blank

APPENDIX E

General Range of Knowledge - Cross-Connection Control Specialist

To effectively prevent unintended backflow into a public water system's distribution system, it is necessary for a cross-connection control specialist to have an understanding of a range of subjects related to cross-connection control. This appendix provides a list of such subjects.

This appendix does not preclude instruction of additional subjects that may be necessary or beneficial to the goal of a prospective or existing cross-connection control specialist being proficient in protecting public health from backflow through cross-connection control measures, and emphasis on particular subjects should be in a manner that best achieves that goal.

(a) GENERAL

- (1) Cross-connection control terminology.
- (2) The history leading to the need for cross-connection control, including causes, impacts, including but not limited to:
 - (A) potable water distribution systems;
 - (B) examples of backflow incidents and actual or potential public health impacts; and
 - (C) evolution of methods of cross-connection control and backflow prevention assemblies.
- (3) Hydraulics (general) – An understanding of hydraulic gradients, pressure variations, flow rates, temperature, the properties of water, backsiphonage, backpressure, and other elements necessary to understand the causes for backflow.
- (4) Public outreach – How to appropriately convey the value of cross-connection control to public water system personnel and the public.

(b) LAWS, REGULATIONS, AND GUIDANCE

- (1) Federal – Applicable federal laws, regulations, and guidance.
- (2) State – California laws and regulations, including, but not limited to, the State Water Resources Control Board's most recent edition of its *Cross-Connection Control Policy Handbook* and other requirements related to cross-connection control.
- (3) Local – An understanding of the need to ensure local requirements are considered and how best to find such requirements.

(c) HAZARD ASSESSMENTS AND METHODS TO PREVENT BACKFLOW

A comprehensive understanding of how to conduct cross-connection surveys of water systems for the purpose of identifying cross-connections, assessing hazards, and identifying the most effective and legally appropriate methods for protection from backflow. At a minimum, the following topics should be considered to achieve such an understanding:

(1) Surveys:

- (A) Preparation (e.g., authority, notification, prioritizing customers/premises, coordinating with public water systems, etc.);
- (B) Design and as-built drawings related to water supply and cross-connection control;
- (C) Public water system schematics;
- (D) How to identify existing and new construction, with an understanding of how construction may impact backflow protection;
- (E) How to identify cross-connections (actual and potential);
- (F) How to identify and differentiate between high hazard and low hazard cross-connections; and
- (G) Problems associated with multi-story buildings, multiple service connections at a premises, typical water-use equipment, etc., and varying types of water service, including irrigation, recycled water, gray water, fire prevention systems, and dual plumbed premises.

(2) Assessing Hazards:

- (A) Identifying and differentiating between premises activities leading to high hazard cross-connections and low hazard cross-connections (for *examples* of high hazard activities, see [Appendix D](#)); and
- (B) Understanding potential public health impacts from backflow associated with the problems in section [A.vii](#) of this appendix.

(3) Assemblies and Methods for Backflow Prevention:

- (A) A comprehensive understanding of approved methods for cross-connection control and preventing backflow with respect to an assessed hazard;
- (B) Identifying unapproved methods for cross-connection control and preventing backflow;
- (C) A understanding of components, design and operation, proper installation and location of backflow prevention assemblies, including air gaps, and backflow prevention assembly field test methods, field test results, and the assessment of air gaps; and
- (D) Identifying unapproved assemblies, as well as those assemblies whose operation and/or state of repair necessitates replacement with an approved assembly.

(d) CROSS-CONNECTION CONTROL PROGRAMS

A comprehensive understanding of the development, elements, and administration of cross-connection control programs, including, but not limited to:

- (1) An ability to assess the federal, state, and local requirements applicable to a public water system's cross-connection control program, such that adherence to the cross-connection control program would result in compliance with the requirements;
- (2) The roles, responsibilities, and authority of individuals and entities involved in the critical elements of a successful plan for cross-connection control (see CCCPH section 3.1.4); and
- (3) The ability to assess the components of a public water system's Cross-Connection Control Plan (see CCCPH section 3.1.4) that best assures the prevention of undesired backflow into the public water system's distribution system, and to communicate deficiencies to public water system personnel.

(e) CROSS-CONNECTION TESTS

A comprehensive understanding of:

- (1) The purpose of a cross-connection test and when a cross-connection test should be performed;
- (2) The ability to develop protocols and make arrangements for cross-connection tests, and subsequently oversee and/or perform such cross-connection tests, in a manner that determines whether interconnections exist between unapproved sources and approved water supplies; and
- (3) Follow-up actions and notifications if a cross-connection test indicates an interconnection.

(f) RECORDKEEPING AND INCIDENT RESPONSE

A comprehensive understanding of:

- (1) The agencies and authorities to be notified in the event of a backflow incident;
- (2) Determining the cause of a backflow incident and the actions necessary to prevent similar incidents in the future;
- (3) Properly documenting a backflow incident, including but not limited to the information in the example backflow incident response form in [Appendix F](#); and
- (4) Properly document the elements associated with surveys and hazard assessments, including those identified in section III of this appendix.

This page intentionally left blank

Appendix F

Example Backflow Incident Reporting Form

This page intentionally left blank

BACKFLOW INCIDENT REPORT FORM

Water System: _____

Water System Number: _____

Incident Date: _____

Incident Time (if known): _____

Incident Location: _____

How was the incident discovered?

Backflow Originated from:

Premise Location: _____

Address: _____

Premise Contact Person: _____ Title: _____

Phone: _____ Email: _____

Connection Type: (please check one)

Industrial Commercial Single-Family Residential Multi-Family Residential

Irrigation Recycled Water Water System Facility

Other: _____

Description and source of backflow substance (please be as descriptive as possible):

If available, please attach an MSDS or other chemical description form

Was the backflow fluid contained within the user side? YES NO

Estimated Number of Affected Persons: _____

Number and description of consumer complaints received:

Did any consumers report illness? Please describe.

If applicable, please describe the consumer notification:

INVESTIGATION

Please describe the water system investigation including time frames:

What was the area system pressure? _____

Is this within typical range: YES NO - typical pressure: _____

Was a sample of the water contaminated by the backflow incident collected and stored before flushing? YES NO

Please describe all sampling:

DDW recommends laboratory or field sampling for the following parameters: total coliform, E. coli, free and total chlorine residual, pH, odor, turbidity, temperature, and color. Additional sampling should be collected at the PWS and regulatory agency's discretion.

CORRECTIVE ACTIONS

Please describe the corrective actions taken by the water system:

Was the chlorine residual increased after the backflow incident discovery? YES NO

Date of the last cross-connection control hazard assessment of the premise with the backflow incident conducted: _____

Did the premise have backflow prevention assemblies? YES NO

Date of most recent backflow prevention assembly test(s): _____

When was the Division of Drinking Water or Local County Health office notified?

Date: _____ Time: _____ Contact Person: _____

Was the Division or Local County Health notified within 24 hours? YES NO

Other agencies or organizations contacted?

CERTIFICATION

Name: _____ Job Title: _____

Certification(s): _____

Please list all cross-connection control related certifications including number and expiration date

I certify that the forgoing information is true and correct to the best of my ability.

Signature: _____ Date: _____

Attach the following applicable documentation

1. Laboratory Test Results
2. Sketch of the cross-connection and modifications
3. MSDS or chemical information forms if chemical hazard is known
4. Applicable backflow assembly test reports including the most recent test before the incident
5. Other relevant supporting documentation

Appendix G

Related Statutes and Regulations

This page intentionally left blank

The following laws and regulations are considered related or tangential to the CCCPH, and are included in a descriptive format to provide additional, relevant background information

California Laws and Regulations

In addition to the California SDWA statutory requirements cited in CCCPH Chapter 1, section 1.3.1, California has statutes addressing certain authorities and requirements that may have had some bearing on the CCCPH or may otherwise be of interest.

- Urban and community water systems must have a written policy on discontinuation of residential service for nonpayment and must not discontinue residential service for nonpayment if certain conditions are met. (CHSC sections 116900 – 116926)
- Senate Bill 1263 (2017) requires that before a person submits an application for a permit for a proposed new public water system, the person shall first submit a preliminary technical report which must include a cost comparison of a new public water system and consolidations with an existing system. (CHSC section 116527)
- Effective June 24, 2015, Senate Bill 88 (SB 88) (Statutes 2015, Chapter 27) added sections 116680-116684 to the CHSC, allowing the State Water Board to require certain water systems that consistently fail to provide safe drinking water to consolidate with, or receive an extension of service from, another public water system. The consolidation can be physical or managerial.
- Local health officers may maintain programs for the control of cross-connections by water users, within water users' premises, where public exposure to backflow may occur. Such programs may include water user premises inspections, collection of fees, certification of backflow prevention assembly¹ (BPA) testers, and other discretionary elements. Local health officer BPA tester certification standards must be consistent with the standards prescribed in the CCCPH. Water users are required to comply with all orders, instructions, regulations, and notices from the local health officer regarding installation, testing, and maintenance of a BPA. (CHSC sections 116800 - 116820).
- The California Building Standards Commission (CBSC) is charged by the California Building Standards Law (CHSC sections 18901 - 18949.31) to administer the processes related to the adoption, approval, and publication of regulations referred to as the California Building Standards Code (Title 24, California Code of Regulation). Title 24 serves as the basis for the minimum design and construction

¹ California statutes use a variety of terms when referencing a 'backflow prevention assembly' (e.g., backflow protective device, backflow protection equipment, backflow prevention device, backflow or back siphonage protection device, backflow preventer, or backflow device). For consistency with industry terminology, 'backflow prevention assembly' is used in the CCCPH, unless directly quoted otherwise.

of buildings in California, and includes the California Plumbing Code (Part 5 of Title 24), which contains requirements pertaining to cross-connection control and backflow prevention.

- A BPA intended to convey or dispense water for human consumption via drinking or cooking must meet California’s “lead free” requirements. (CHSC section 116875)
- Limits are established for the installation of backflow protection equipment where automatic fire sprinkler systems are utilized. (CHSC section 13114.7)².
- Cross-connection control must be addressed in engineering reports that are required (CCR Title 22, section 60323) for recycled water projects. (Wat. Code section 13552.8)
- If a public agency requires the use of recycled water for toilet and urinal flushing in a structure (except certain mental health facilities), the public health agency must prepare an engineering report that addresses cross-connection control. (Wat. Code section 13554)
- Prior to indoor use of recycled water in a condominium project, the entity delivering the recycled water must submit a report, for State Water Board³ approval, and include the following related to cross-connection control (Wat. Code section 13553(d)(1)):
 - The condominium project must be provided with a backflow prevention assembly approved by the State Water Board.
 - The backflow prevention assembly must be inspected and tested annually by a certified tester.
 - The condominium project must be tested by the recycled water agency or local agency at least once every four years for indications of possible cross-connections between the condominium’s potable and non-potable systems.
- California’s Department of Water Resources was required to convene a task force, known as the 2002 Recycled Water Task Force, to identify constraints, impediments, and opportunities for the increased use of recycled water and report

² CHSC section 13114.7 historically provided potential limits for backflow prevention assemblies on fire sprinklers. Even though current standards differ from the language stated in CHSC section 13114.7, it is still being provided as a historical reference as there may still be installations with the now outdated limits established in section 13114.7

³ The California Department of Public Health’s authority and responsibility pertaining to this reference was transferred to the State Water Board via Senate Bill 861 (2014, Chapter 35). As such, applicable statutory mandates that may refer to “California Department of Public Health” or “Department” may be referred to as “State Water Board” in this document.

to the Legislature by July 1, 2003. The task force was also asked to advise and make recommendations concerning cross-connection control, including the applicability of visual inspections instead of pressure tests for cross-connections between potable and non-potable water systems. (Wat. Code section 13578(b)(1)). The final report⁴ provided the following recommendations to the State Water Board – Division of Drinking Water (Division):

- Prepare guidance on dual plumbed regulations (22 CCR sections 60313-60316) consistent with Appendix J of plumbing code (now Chapter 15 of 2019 California Plumbing Code, formerly Chapter 16A).
 - Support thorough assessment of risk associated with cross-connections between disinfection tertiary recycled water and potable water.
 - Ensure uniform interpretation of cross-connection control requirement of Title 22 regulations (recycled water) and Title 17 (cross-connection control regulations)
 - Recommend stakeholders to review draft Title 17 regulations.
- A person engaged in the salvage, purchase, or sale of scrap metal who knowingly possesses a backflow prevention assembly (or connections to the assembly or any part of the assembly), or who failed to report the possession of such items, which was previously owned by a utility or public agency, is guilty of a crime. (Pen. Code section 496e)
 - Junk dealers or recyclers who possess a backflow prevention assembly (or connections to that assembly or any part of the assembly) without a written certification from the agency or utility owning or previously owning the assembly will be liable to the agency or utility for the wrongful possession. (Civ. Code section 3336.5 and, similarly, Bus. & Prof. Code section 21609.1)

Please note that a number of the codes, regulations, and statutes cited above are implemented under the authority of regulatory entities other than the State Water Board, and would therefore be beyond the scope of this CCCPH. The intent of providing such citations was to increase general awareness with respect to other potential statutory requirements associated with cross-connection control. The list is not exhaustive and does not include other requirements that may exist, including those via regulations that may have been adopted by an appropriate regulatory entity.

Federal Laws and Regulations

⁴ California Department of Water Resources. (2003). *Water Recycling 2030: Recommendations of California's Recycled Water Task Force*

All suppliers of domestic water to the public are subject to regulations adopted by the U.S. Environmental Protection Agency (EPA) under the U.S. Safe Drinking Water Act (SDWA) of 1974, as amended (42 U.S.C. section 300f et seq.), as well as by the State Board under the California SDWA (Health & Saf. Code, div. 104, pt. 12, ch. 4, section 116270 et seq.). Additionally, the State Water Board has been delegated primacy - the responsibility and authority to administer U.S. EPA's drinking water regulations within California – on the condition that California adopt enforceable requirements no less stringent than U.S. EPA's.

The U.S. EPA currently has no distinct cross-connection control requirements that apply broadly to public water systems (PWS); however, the importance of cross-connection control is evident by the issue papers and guidance documents developed by U.S. EPA and their recognition that cross-connections and backflow represent a significant public health risk (see discussion in Chapter 2). Although U.S. EPA currently has no distinct cross-connection control requirements, the subject of cross-connection or backflow prevention assemblies is included in the U.S. SDWA and the Code of Federal Regulations (C.F.R.) in relation to PWS, including the following⁵:

- If used exclusively for non-potable services, a backflow prevention assembly (BPA) is exempt from the federal lead prohibitions. (42, U.S.C. section 300g)
- Allows increasing disinfectant concentrations in a PWS distribution system in the event of a cross-connection (backflow) event. (40 C.F.R. section 141.130(d))
- Proper maintenance of the distribution system, including cross-connection control, is identified as a best available technology (BAT) for microbial contaminant control. (40 C.F.R. section 141.63(e))
- Under the federal Revised Total Coliform Rule, a PWS having a cross-connection control program is one of the enhancements necessary to reduce monitoring for a PWS that had been under an increased monitoring frequency. (40 C.F.R. section 141.854(h)(2))
- Under the federal Revised Total Coliform Rule, a PWS having a cross-connection control program is a criterion for a state to allow a reduced monitoring frequency (40 C.F.R. section 141.855(d)(1))
- If a state allows the monitoring frequency reductions previously mentioned under the federal Revised Total Coliform Rule, a state is required to include in its primacy package to U.S. EPA how a PWS will be required to demonstrate cross-connection control. (40 C.F.R. section 142.16(q))

⁵ For requirements unrelated to cross-connection control, please consult California's laws and regulations specific to the topic of interest. California may have more stringent requirements (e.g., reduced monitoring allowed via federal regulations may be prohibited in California).