

ORDER R3-2017-0018
NPDES NO. CA0047791

WASTE DISCHARGE REQUIREMENTS
FOR OLIVE SPRINGS QUARRY, INC.
OLIVE SPRINGS QUARRY
DISCHARGE TO SOQUEL CREEK

The following Discharger is subject to waste discharge requirements as set forth in this Order:

Table 1. Discharger Information

| | |
|-------------------------|----------------------------|
| Discharger | Olive Springs Quarry, Inc. |
| Name of Facility | Olive Springs Quarry |
| Facility Address | 1299 Olive Springs Road |
| | Soquel, CA 95073 |
| | Santa Cruz County |

Table 2. Discharge Location

| Discharge Point | Effluent Description | Discharge Point Latitude | Discharge Point Longitude | Receiving Water |
|------------------------|--|---------------------------------|----------------------------------|------------------------|
| 002 | Treated process wastewater and storm water | 37° 03' 30" N | 121° 55' 15" W | Soquel Creek |

Table 3. Administrative Information

| | |
|--|---------------------------|
| This Order was adopted by the Central Coast Water Board on: | July 13, 2017 |
| This Order shall become effective on: | October 1, 2017 |
| This Order shall expire on: | September 30, 2022 |
| The Discharger shall file a Report of Waste Discharge as an application for reissuance of waste discharge requirements in accordance with title 23, California Code of Regulations, and an application for reissuance of a National Pollutant Discharge Elimination System (NPDES) permit no later than: | April 3, 2022 |
| The U.S. Environmental Protection Agency (U.S. EPA) and the Central Coast Water Board have classified this discharge as follows: | Minor |

IT IS HEREBY ORDERED, that Order No. R3-2010-0039 is superseded upon the effective date of this Order, and, in order to meet the provisions contained in division 7 of the Water Code (commencing with section 13000) and regulations adopted thereunder, and the provisions of the federal Clean Water Act (CWA) and regulations and guidelines adopted thereunder, the Discharger shall comply with the requirements in this amended Order.



Digitally signed by Michael
Thomas

Date: 2017.08.14 10:44:57 -07'00'

for John M. Robertson, Executive Officer

Contents

I. Facility information..... 1
II. Findings 1
III. Discharge Prohibitions..... 2
IV. Effluent Limitations and Discharge Specifications..... 2
 A. Effluent Limitations – Discharge Point No. 002..... 2
 B. Land Discharge Specifications – Not Applicable..... 5
 C. Recycling Specifications – Not Applicable..... 5
V. Receiving Water Limitations..... 5
 A. Surface Water Limitation 5
VI. Provisions..... 7
 A. Standard Provisions..... 7
 1. Reopener Provisions..... 8
 2. Special Studies, Technical Reports and Additional Monitoring Requirements..... 8
 3. Best Management Practices and Pollution Prevention – Not Applicable 9
 4. Construction, Operation and Maintenance Specifications..... 9
 5. Special Provisions for Municipal Facilities (POTWs Only) – Not Applicable 9
 6. Other Special Provisions..... 9
 7. Compliance Schedules – Not Applicable 9
VII. Compliance Determination..... 10
 D. General..... 10
 E. Multiple Sample Data 10

Tables

Table 1. Discharger Information 1
Table 2. Discharge Location..... 1
Table 3. Administrative Information..... 1
Table 4. Effluent Limitations..... 2
Table 5. Organic Substances Water Quality Objectives..... 6
Table 6. Hardness Dependent Metal Criteria 7
Table 7. Toxicity Reduction Evaluation Schedule..... 9

Attachments

Attachment A – Definitions A-1
Attachment B – Map B-1
Attachment C – Flow Schematic..... C-1
Attachment D – Standard Provisions..... D-1
Attachment E – Monitoring and Reporting Program E-1
Attachment F – Fact Sheet..... F-1

I. FACILITY INFORMATION

Information describing the Olive Springs Quarry (hereinafter the Facility) is summarized in Table 1 and in Fact Sheet (Attachment F) sections I and II.

II. FINDINGS

The California Regional Water Quality Control Board, Central Coast Region (hereinafter Central Coast Water Board), finds:

- A. Legal Authorities.** This Order serves as waste discharge requirements (WDRs) pursuant to article 4, chapter 4, division 7 of the C California Water Code (commencing with section 13260). This Order is also issued pursuant to section 402 of the federal Clean Water Act (CWA) and implementing regulations adopted by the U.S. Environmental Protection Agency (U.S. EPA) and chapter 5.5, division 7 of the Water Code (commencing with section 13370). It shall serve as an NPDES permit for point source discharges from this facility to surface waters.
- B. Background and Rationale for Requirements.** The Central Coast Water Board developed the requirements in this Order based on information submitted as part of the application, through monitoring and reporting programs, and other available information. The Fact Sheet (Attachment F), which contains background information and rationale for the requirements in this Order, is hereby incorporated into and constitutes findings for this Order. Attachments A through E are also incorporated into this Order.
- C. Provisions and Requirements Implementing State Law.** The provisions/requirements in subsections III.B, III.C, and IV.B are included to implement state law only. These provisions/requirements are not required or authorized under the federal CWA; consequently, violations of these provisions/requirements are not subject to the enforcement remedies that are available for NPDES violations.
- D. Notification of Interested Parties.** The Central Coast Water Board has notified the Discharger and interested agencies and persons of its intent to prescribe WDRs for the discharge and has provided them with an opportunity to submit their written comments and recommendations. Details of the notification are provided in the Fact Sheet of this Order.
- E. Consideration of Public Comment.** The Central Coast Water Board, in a public meeting, heard and considered all comments pertaining to the discharge. Details of the Public Hearing are provided in the Fact Sheet of this Order.

THEREFORE, IT IS HEREBY ORDERED, that Order No. R3-2010-0039 is rescinded upon the effective date of this Order except for enforcement purposes, and, in order to meet the provisions contained in division 7 of the Water Code (commencing with section 13000) and regulations adopted thereunder, and the provisions of the CWA and regulations and guidelines adopted thereunder, the Discharger shall comply with the requirements in this Order. This action in no way prevents the Central Coast Water Board from taking enforcement action for past violations of the previous Order. If any part of this Order is subject to a temporary stay of enforcement, unless otherwise specified, the Discharger shall comply with the analogous portions of the previous Order, which shall remain in effect for all purposes during the pendency of the stay.

III. DISCHARGE PROHIBITIONS

- A. Discharge of process wastewater at a location or in a manner, other than as described by this Order, is prohibited.
- B. The discharge of any waste not specifically regulated by this Order, excluding storm water regulated by General Permit No. CAS000001 (Waste Discharge Requirements for Discharges of Storm Water Associated with Industrial Activities), is prohibited.
- C. The overflow or bypass of wastewater from the Discharger’s collection, treatment, or disposal facilities and the subsequent discharge of untreated or partially treated wastewater, except as provided for in Attachment D, Standard Provisions I.G (Bypass), is prohibited.
- D. The discharge shall not cause or contribute to adverse impacts to beneficial uses of water or to threatened or endangered species and their habitat.
- E. Creation of a condition of pollution, contamination, or nuisance, as defined by Section 13050 of the CWC, is prohibited.
- F. Discharge of fuels, greases, or oils to the facility’s treatment ponds, the storm drainage system, or to waters of the United States and/or waters of the State is prohibited.
- G. The discharge of radioactive substances is prohibited.

IV. EFFLUENT LIMITATIONS AND DISCHARGE SPECIFICATIONS

A. Effluent Limitations – Discharge Point No. 002

The Discharger shall comply with the following effluent limitations at Discharge Point No. 002 with compliance measured at Monitoring Location EFF-002 as described in the attached Monitoring and Reporting Program (MRP).

Table 4. Effluent Limitations

| Parameter | Units | Effluent Limitations | |
|-----------------------------------|----------------|------------------------|---------------------|
| | | Average Monthly | Maximum Daily |
| pH | standard units | 7.0 – 8.3 at all times | |
| Total Suspended Solids (TSS) | mg/L | --- | 50 |
| Settleable Solids | ml/L | 0.3 | --- |
| Chronic Toxicity | Pass/Fail | --- | Pass ^[1] |
| Mercury, Total Recoverable | µg/L | 0.050 | 0.10 |
| Selenium, Total Recoverable | µg/L | 10 | 20 |
| Cyanide, Total Recoverable | µg/L | 4.3 | 8.5 |
| Antimony, Total Recoverable | µg/L | 6.0 | 12 |
| Arsenic, Total Recoverable | µg/L | 50 | 100 |
| Beryllium, Total Recoverable | µg/L | 4.0 | 8.0 |
| Cadmium, Total Recoverable | µg/L | 5.0 | 10 |
| Chromium (III), Total Recoverable | µg/L | 50 | 100 |
| Chromium (IV), Total Recoverable | µg/L | 8.1 | 16 |
| Copper, Total Recoverable | µg/L | 22 | 44 |
| Lead, Total Recoverable | µg/L | 13 | 25 |
| Nickel, Total Recoverable | µg/L | 100 | 201 |
| Silver, Total Recoverable | µg/L | 17 | 34 |
| Thallium, Total Recoverable | µg/L | 1.7 | 3.4 |

| Parameter | Units | Effluent Limitations | |
|----------------------------|----------|----------------------|---------------|
| | | Average Monthly | Maximum Daily |
| Zinc, Total Recoverable | µg/L | 164 | 329 |
| Asbestos | fibers/L | 7,000,000 | 14,000,000 |
| 2,3,7,8 TCDD | µg/L | 0.00000013 | 0.00000026 |
| Acrolein | µg/L | 320 | 642 |
| Acrylonitrile | µg/L | 0.059 | 0.12 |
| Benzene | µg/L | 1.0 | 2.0 |
| Bromoform | µg/L | 4.3 | 8.6 |
| Carbon Tetrachloride | µg/L | 0.25 | 0.50 |
| Chlorobenzene | µg/L | 30 | 60 |
| Chlorodibromomethane | µg/L | 0.40 | 0.80 |
| Chloroform | µg/L | 80 | 160 |
| Dichlorobromomethane | µg/L | 0.56 | 1.12 |
| 1,1-Dichloroethane | µg/L | 5.0 | 10 |
| 1,2-Dichloroethane | µg/L | 0.38 | 0.76 |
| 1,1-Dichloroethylene | µg/L | 0.057 | 0.11 |
| 1,2-Dichloropropane | µg/L | 0.52 | 1.0 |
| 1,3-Dichloropropylene | µg/L | 0.50 | 1.0 |
| Ethylbenzene | µg/L | 300 | 602 |
| Methyl Bromide | µg/L | 48 | 96 |
| Methylene Chloride | µg/L | 4.7 | 9.4 |
| 1,1,2,2-Tetrachloroethane | µg/L | 0.17 | 0.34 |
| Tetrachloroethylene | µg/L | 0.80 | 1.6 |
| Toluene | µg/L | 150 | 301 |
| 1,2-Trans-Dichloroethylene | µg/L | 10 | 20 |
| 1,1,1-Trichloroethane | µg/L | 200 | 401 |
| 1,1,2-Trichloroethane | µg/L | 0.60 | 1.2 |
| Trichloroethylene | µg/L | 2.7 | 5.4 |
| Vinyl Chloride | µg/L | 0.50 | 1.0 |
| 2-Chlorophenol | µg/L | 120 | 241 |
| 2,4-Dichlorophenol | µg/L | 93 | 187 |
| 2,4-Dimethylphenol | µg/L | 540 | 1,083 |
| 2-methyl-4,6-dinitrophenol | µg/L | 13 | 27 |
| 2,4-Dinitrophenol | µg/L | 70 | 140 |
| Pentachlorophenol | µg/L | 0.28 | 0.56 |
| Phenol | µg/L | 1.0 | 2.0 |
| 2,4,6-Trichlorophenol | µg/L | 2.1 | 4.2 |
| Acenaphthene | µg/L | 1,200 | 2,407 |
| Anthracene | µg/L | 9,600 | 19,259 |
| Benzidine | µg/L | 0.00012 | 0.00024 |
| Benzo(a)Anthracene | µg/L | 0.0044 | 0.0088 |
| Benzo(a)Pyrene | µg/L | 0.0044 | 0.0088 |
| Benzo(b)Fluoranthene | µg/L | 0.0044 | 0.0088 |
| Benzo(k)Fluoranthene | µg/L | 0.0044 | 0.0088 |
| Bis(2-Chloroethyl)Ether | µg/L | 0.031 | 0.062 |

| Parameter | Units | Effluent Limitations | |
|-----------------------------|-------|----------------------|---------------|
| | | Average Monthly | Maximum Daily |
| Bis(2-Chloroisopropyl)Ether | µg/L | 1,400 | 2,809 |
| Bis(2-Ethylhexyl)Phthalate | µg/L | 1.8 | 3.6 |
| Butylbenzyl Phthalate | µg/L | 3,000 | 6,019 |
| 2-Chloronaphthalene | µg/L | 1,700 | 3,411 |
| Chrysene | µg/L | 0.0044 | 0.0088 |
| Dibenzo(a,h)Anthracene | µg/L | 0.0044 | 0.0088 |
| 1,2-Dichlorobenzene | µg/L | 600 | 1,204 |
| 1,3-Dichlorobenzene | µg/L | 400 | 802 |
| 1,4-Dichlorobenzene | µg/L | 5.0 | 10 |
| 3,3-Dichlorobenzidine | µg/L | 0.040 | 0.1 |
| Diethyl Phthalate | µg/L | 23,000 | 46,142 |
| Dimethyl Phthalate | µg/L | 313,000 | 627,937 |
| Di-n-Butyl Phthalate | µg/L | 2,700 | 5,417 |
| 2,4-Dinitrotoluene | µg/L | 0.11 | 0.22 |
| 1,2-Diphenylhydrazine | µg/L | 0.040 | 0.080 |
| Fluoranthene | µg/L | 300 | 602 |
| Fluorene | µg/L | 1,300 | 2,608 |
| Hexachlorobenzene | µg/L | 0.00075 | 0.0015 |
| Hexachlorobutadiene | µg/L | 0.44 | 0.88 |
| Hexachlorocyclopentadiene | µg/L | 50 | 100 |
| Hexachloroethane | µg/L | 1.9 | 3.8 |
| Indeno(1,2,3-cd)Pyrene | µg/L | 0.0044 | 0.0088 |
| Isophorone | µg/L | 8.4 | 17 |
| Nitrobenzene | µg/L | 17 | 34 |
| N-Nitrosodimethylamine | µg/L | 0.00069 | 0.0014 |
| N-Nitrosodi-n-Propylamine | µg/L | 0.0050 | 0.010 |
| N-Nitrosodiphenylamine | µg/L | 5.0 | 10 |
| Pyrene | µg/L | 960 | 1,926 |
| 1,2,4-Trichlorobenzene | µg/L | 5.0 | 10 |
| Aldrin | µg/L | 0.00013 | 0.00026 |
| alpha-BHC | µg/L | 0.0039 | 0.0078 |
| beta-BHC | µg/L | 0.014 | 0.028 |
| gamma-BHC | µg/L | 0.019 | 0.038 |
| Chlordane | µg/L | 0.00057 | 0.0011 |
| 4,4'-DDT | µg/L | 0.00059 | 0.0012 |
| 4,4'-DDE | µg/L | 0.00059 | 0.0012 |
| 4,4'-DDD | µg/L | 0.00083 | 0.0017 |
| Dieldrin | µg/L | 0.00014 | 0.00028 |
| alpha-Endosulfan | µg/L | 0.046 | 0.092 |
| beta-Endosulfan | µg/L | 0.046 | 0.092 |
| Endosulfan Sulfate | µg/L | 110 | 221 |
| Endrin | µg/L | 0.029 | 0.059 |
| Endrin Aldehyde | µg/L | 0.76 | 1.5 |
| Heptachlor | µg/L | 0.00021 | 0.00042 |

| Parameter | Units | Effluent Limitations | |
|-------------------------|-------|----------------------|---------------|
| | | Average Monthly | Maximum Daily |
| Heptachlor Epoxide | µg/L | 0.00010 | 0.00020 |
| PCBs sum ^[2] | µg/L | 0.00017 | 0.00034 |
| Toxaphene | µg/L | 0.00016 | 0.00033 |

^[1] The limitation for chronic toxicity shall be "Pass" or "P" as described in Section V.A.. of the Monitoring and Reporting Program (MRP) attached to this Order.

^[2] Includes aroclors 1242, 1254, 1221, 1232, 1248, 1260, and 1016.

B. Land Discharge Specifications – Not Applicable

C. Recycling Specifications – Not Applicable

V. RECEIVING WATER LIMITATIONS

A. Surface Water Limitation

Receiving water limitations are based on water quality objectives contained in the Basin Plan and are a required part of this Order. The discharge from the wastewater treatment facility shall not cause the following in the receiving waters:

1. Waters shall be free of coloration that causes nuisance or adversely affects beneficial uses. Coloration attributable to materials of waste origin shall not be greater than 15 units or 10 percent above natural background color, whichever is greater.
2. Waters shall not contain taste or odor-producing substances in concentrations that impart undesirable tastes or odors to fish flesh or other edible products of aquatic origin, that cause nuisance, or that adversely affect beneficial uses.
3. Waters shall not contain floating material, including solids, liquids, foams, and scum, in concentrations that cause nuisance or adversely affect beneficial uses.
4. Waters shall not contain suspended material in concentrations that cause nuisance or adversely affects beneficial uses.
5. Waters shall not contain settleable material in concentrations that result in deposition of material that causes nuisance or adversely affects beneficial uses.
6. Waters shall not contain oils, greases, waxes, or other similar materials in concentrations that result in a visible film or coating on the surface of the water or on objects in the water, that cause nuisance, or that otherwise adversely affect beneficial uses.
7. Waters shall not contain biostimulatory substances in concentrations that promote aquatic growths to the extent that such growths cause nuisance or adversely affect beneficial uses.
8. The suspended sediment load and suspended sediment discharge rate to surface waters shall not be altered in such a manner as to cause nuisance or adversely affect beneficial uses.
9. Waters shall be free of changes in turbidity that cause nuisance or adversely affect beneficial uses. Increase in turbidity attributable to controllable water quality factors shall not exceed the following limits.

- a. Where natural turbidity is between 0 and 50 Jackson Turbidity Units (JTU), increases shall not exceed 20 percent.
 - b. Where natural turbidity is between 50 and 100 JTU, increases shall not exceed 10 JTU.
 - c. Where natural turbidity is greater than 100 JTU, increases shall not exceed 10 percent.
10. The pH value shall not be depressed below 7.0 nor raised above 8.3. The change in normal ambient pH levels shall not exceed 0.5 in fresh water.
 11. Dissolved oxygen concentrations in receiving waters shall not be reduced below 7.0 mg/L at any time.
 12. At no time or place shall the temperature be increased by more than 5°F above natural receiving water temperature.
 13. All waters shall be maintained free of toxic substances in concentrations which are toxic to, or which produce detrimental physiological responses in, human, plant, animal, or aquatic life. Survival of aquatic life in surface waters subjected to a waste discharge or other controllable water quality conditions shall not be less than that for the same water body in areas unaffected by the waste discharge.
 14. The discharge of wastes shall not cause concentrations of unionized ammonia (NH₃) to exceed 0.025 mg/L (as N) in the receiving water.
 15. No individual pesticide or combination of pesticides shall reach concentrations that adversely affect the beneficial uses of the receiving water. There shall be no increase in pesticide concentrations found in bottom sediments or aquatic life. For waters where existing concentrations are presently nondetectable or where beneficial uses would be impaired by concentrations in excess of nondetectable levels, total identifiable chlorinated hydrocarbon pesticides shall not be present at concentrations detectable within the accuracy of analytical methods as prescribed in Standard Methods for the Examination of Water and Wastewater, latest edition, or other equivalent methods approved by the Executive Officer.
 16. Waters shall not contain organic substances in concentrations greater than the following:

Table 5. Organic Substances Water Quality Objectives

| Parameter | Water Quality Objective |
|-------------------------------------|-------------------------|
| Phenol | 1.0 µg/L |
| Methylene Blue Activated Substances | 0.2 mg/L |
| Total Phenols | 0.1 mg/L |
| PCBs | 0.3 µg/L |
| Phthalate Esters | 0.002 µg/L |

17. Radionuclides shall not be present in concentrations that are deleterious to human, plant, animal, or aquatic life; or result in the accumulation of radionuclides in the food web to an extent, which presents a hazard to human, plant, animal, or aquatic life. In no

circumstance shall receiving waters contain concentrations of radionuclides in excess of the maximum contaminant levels (MCLs) for radioactivity presented in Table 4 of Title 22 California Code of Regulations, Division 4, Chapter 15, Article 5.

18. Receiving waters shall not contain concentrations of chemical constituents in excess of the primary maximum contaminant levels (MCLs) specified for drinking water in Table 64431-A (Primary MCLs for Inorganic Chemicals) and Table 64444-A (Primary MCLs for Organic Chemicals) of Title 22 California Code of Regulations, Division 4, Chapter 15.
19. Fecal coliform concentration, based on a minimum of not less than five samples for any 30-day period, shall not exceed a log mean of 200 per 100 mL, nor shall more than 10 percent of samples collected during any 30-day period exceed 400 per 100 mL.
20. Waters used for irrigation and livestock watering shall not contain chemical constituents in excess of those levels specified for irrigation and livestock watering in Section III, Table 3-4 of the Basin Plan.
21. Receiving waters shall not contain concentrations of chemical constituents in amounts that adversely affect the agricultural beneficial use (Interpretation of adverse effect shall be derived from guidelines of the University of California Agricultural Extension Service presented in Section III, Table 3-3 of the Basin Plan).
22. The following concentrations of metals shall not be exceeded for the protection of aquatic life.

Table 6. Hardness Dependent Metal Criteria

| Parameter | Receiving Water Hardness (mg/L) | |
|-----------|---------------------------------|------------------------------|
| | > 100 mg/L CaCO ₃ | < 100 mg/L CaCO ₃ |
| Cadmium | 0.03 | 0.004 |
| Chromium | 0.05 | 0.05 |
| Copper | 0.03 | 0.01 |
| Lead | 0.03 | 0.03 |
| Mercury | 0.0002 | 0.0002 |
| Nickel | 0.4 | 0.1 |
| Zinc | 0.2 | 0.004 |

B. Groundwater Limitations – Not Applicable

VI. PROVISIONS

A. Standard Provisions

1. **Federal Standard Provisions.** The Discharger shall comply with all Standard Provisions included in Attachment D of this Order.
2. **Central Coast Water Board Standard Provisions.** The Discharger shall comply with the Central Coast Water Board Standard Provisions included in Attachment D of this Order.

B. Monitoring and Reporting Program (MRP) Requirements

The Discharger shall comply with the MRP, and future revisions thereto, in Attachment E of this Order. All monitoring shall be conducted according to 40 CFR 136, *Guidelines Establishing Test Procedures for Analysis of Pollutants*.

C. Special Provisions

1. Reopener Provisions

This Order may be reopened and modified in accordance with NPDES regulations at 40 CFR 122 and 124, as necessary, to include additional conditions or limitations based on newly available information or to implement any U.S. EPA approved, new, State WQO.

2. Special Studies, Technical Reports and Additional Monitoring Requirements

a. Toxicity Reduction Requirements

If the discharge consistently exceeds an effluent limitation for toxicity specified by section IV.A of this Order, the Discharger shall conduct a Toxicity Reduction Evaluation (TRE) in accordance with the Discharger's TRE Workplan.

A TRE is a study conducted in a step-wise process designed to identify the causative agents of effluent or ambient toxicity, isolate the sources of toxicity, evaluate the effectiveness of toxicity control options, and then confirm the reduction in toxicity. The first steps of the TRE consist of the collection of data relevant to the toxicity, including additional toxicity testing, and an evaluation of facility operations and maintenance practices, and best management practices. A Toxicity Identification Evaluation (TIE) may be required as part of the TRE, if appropriate. A TIE is a set of procedures to identify the specific chemical(s) responsible for toxicity. These procedures are performed in three phases: characterization; identification; and confirmation using aquatic organism toxicity tests. The TRE shall include all reasonable steps to identify the source of toxicity. The Discharger shall take all reasonable steps to reduce toxicity to the required level once the source of toxicity is identified.

The Discharger shall maintain a TRE Workplan, which describes steps that the Discharger intends to follow if a toxicity effluent limitation in this Order is exceeded. The Workplan shall be prepared in accordance with current technical guidance and reference material, including EPA/600/2-88-062, and shall describe, at a minimum:

- i. Actions proposed to investigate/identify the causes/sources of toxicity;
- ii. Actions proposed to mitigate the discharge's adverse effects, to correct the non-compliance, and/or to prevent the recurrence of acute or chronic toxicity; and
- iii. A schedule to implement these actions.

When monitoring detects effluent toxicity greater than a limitation in this Order, the Discharger shall resample immediately, if the discharge is continuing, and retest for whole effluent toxicity. Results of an initial failed test and results of subsequent monitoring shall be reported to the Executive Officer (EO) as soon as possible after receiving monitoring results. The EO will determine whether to initiate enforcement

action, whether to require the Discharger to implement a TRE, or to implement other measures. The Discharger shall conduct a TRE considering guidance provided by the USEPA’s Toxicity Reduction Evaluation Procedures, Phases 1, 2, and 3 (EPA document Nos. EPA 600/3-88/034, 600/3-88/035, and 600/3-88/036, respectively). A TRE, if necessary, shall be conducted in accordance with the following schedule.

Table 7. Toxicity Reduction Evaluation Schedule

| Action Step | When Required |
|---|---|
| Take all reasonable measures necessary to immediately reduce toxicity, where the source is known. | Within 24 hours of identification of noncompliance. |
| Initiate the TRE in accordance to the Workplan. | Within 7 days of notification by the EO. |
| Conduct the TRE following the procedures in the Workplan. | Within the period specified in the Workplan (not to exceed one year without an approved Workplan) |
| Submit the results of the TRE, including summary of findings, required corrective action, and all results and data. | Within 60 days of completion of the TRE. |
| Implement corrective actions to meet Permit limits and conditions. | To be determined by the EO. |

3. Best Management Practices and Pollution Prevention – Not Applicable

4. Construction, Operation and Maintenance Specifications

- a. **Erosion and Sediment Control.** By October 1 of each year, the Discharger shall inspect, install, and have proper operational condition all erosion and sediment control systems necessary to ensure compliance with this Order.

5. Special Provisions for Municipal Facilities (POTWs Only) – Not Applicable

6. Other Special Provisions

- a. **Discharges of Storm Water.** This Order applies to discharges of process wastewater and storm water from Discharge Point No. 002. All other storm water runoff from the Olive Springs Quarry can be discharged only in accordance with the requirements of the State Water Resources Control Board’s Water Quality Order 2014-0057-DWQ, NPDES General Permit No. CAS000001, *General Permit for Storm Water Discharges Associated with Industrial Activities*.
- b. **Timber Harvesting Plan.** Order No. R3-2010-0039 required that the Discharger collect, treat, and monitor all runoff from the timber harvesting site harvested in accordance with the Timber Harvesting Plan (No. 1-04-138 SCR) approved by the Director of Forestry on February 16, 2005. This provision has been retained in this Order to ensure compliance with the harvesting plan.

7. Compliance Schedules – Not Applicable

VII. COMPLIANCE DETERMINATION

D. General

Compliance with effluent limitations for reportable pollutants shall be determined using sample reporting protocols defined in the MRP and Attachment A of this Order. For purposes of reporting and administrative enforcement by the Central Coast and State Water Boards, the Discharger shall be deemed out of compliance with effluent limitations if the concentration of the reportable pollutant in the monitoring sample is greater than the effluent limitation and greater than or equal to the reported Minimum Level (ML). For priority pollutants, the methods must meet the lowest MLs specified in Attachment 4 of the SIP. If no methods are specified for a given pollutant it shall be analyzed by methods approved by this Regional Water Board or the State Water Board. If more than one analytical test method is listed for a given parameter, the Discharger must select from the listed methods and corresponding MLs.

E. Multiple Sample Data

When determining compliance with a measure of central tendency (arithmetic mean, geometric mean, median, etc.) of multiple samples analyses and the data set contains one or more reported determinations of "Detected, but Not Quantified" ("DNQ", or "Not Detected" (ND), the Discharger shall compute the median in place of the arithmetic mean in accordance with the following procedure:

1. The data set shall be ranked from low to high, ranking the reported ND determinations lowest, DNQ determinations next, followed by quantified values (if any). The order of the individual ND or DNQ determinations is unimportant.
 - a. The median value of the data set shall be determined. If the data set has an odd number of data points, then the median is the middle value. If the data set has an even number of data points, then the median is the average of the two values around the middle unless one or both of the points are ND or DNQ, in which case the median value shall be the lower of the two data points where DNQ is lower than a value and ND is lower than DNQ.

D. Average Monthly Effluent Limitation (AMEL)

If the average of daily discharges over a calendar month exceeds the AMEL for a given parameter, an alleged violation will be flagged and the Discharger will be considered out of compliance for each day of that month for that parameter (e.g., resulting in 31 days of non-compliance in a 31-day month). The average of daily discharges over the calendar month that exceeds the AMEL for a parameter will be considered out of compliance for that month only. If only a single sample is taken during the calendar month and the analytical result for that sample exceeds the AMEL, the Discharger will be considered out of compliance for that calendar month. For any one calendar month during which no sample (daily discharge) is taken, no compliance determination can be made for that calendar month.

E. Average Weekly Effluent Limitation (AWEL)

If the average of daily discharges over a calendar week exceeds the AWEL for a given parameter, an alleged violation will be flagged and the Discharger will be considered out of compliance for each day of that week for that parameter, resulting in 7 days of non-compliance. The average of daily discharges over the calendar week that exceeds the AWEL for a parameter will be considered out of compliance for that week only. If only a single sample is taken during the calendar week and the analytical result for that sample exceeds

the AWEL, the Discharger will be considered out of compliance for that calendar week. For any one calendar week during which no sample (daily discharge) is taken, no compliance determination can be made for that calendar week.

F. Maximum Daily Effluent Limitation (MDEL)

If a daily discharge exceeds the MDEL for a given parameter, an alleged violation will be flagged and the Discharger will be considered out of compliance for that parameter for that 1 day only within the reporting period. For any 1 day during which no sample is taken, no compliance determination can be made for that day.

ATTACHMENT A – DEFINITIONS

Arithmetic Mean (μ)

Also called the average, is the sum of measured values divided by the number of samples. For ambient water concentrations, the arithmetic mean is calculated as follows:

$$\text{Arithmetic mean} = \mu = \sum x / n \quad \text{where: } \sum x \text{ is the sum of the measured ambient water concentrations, and } n \text{ is the number of samples.}$$

Average Monthly Effluent Limitation (AMEL)

The highest allowable average of daily discharges over a calendar month, calculated as the sum of all daily discharges measured during a calendar month divided by the number of daily discharges measured during that month.

Average Weekly Effluent Limitation (AWEL)

The highest allowable average of daily discharges over a calendar week (Sunday through Saturday), calculated as the sum of all daily discharges measured during a calendar week divided by the number of daily discharges measured during that week.

Bioaccumulate

Those substances taken up by an organism from its surrounding medium through gill membranes, epithelial tissue, or from food and subsequently concentrated and retained in the body of the organism.

Carcinogenic

Pollutants or substances that are known to cause cancer in living organisms.

Coefficient of Variation (CV)

CV is a measure of the data variability and is calculated as the estimated standard deviation divided by the arithmetic mean of the observed values.

Daily Discharge

Daily Discharge is defined as either: (1) the total mass of the constituent discharged over the calendar day (12:00 am through 11:59 pm) or any 24-hour period that reasonably represents a calendar day for purposes of sampling (as specified in the permit), for a constituent with limitations expressed in units of mass or; (2) the unweighted arithmetic mean measurement of the constituent over the day for a constituent with limitations expressed in other units of measurement (e.g., concentration).

The daily discharge may be determined by the analytical results of a composite sample taken over the course of one day (a calendar day or other 24-hour period defined as a day) or by the arithmetic mean of analytical results from one or more grab samples taken over the course of the day.

For composite sampling, if 1 day is defined as a 24-hour period other than a calendar day, the analytical result for the 24-hour period will be considered as the result for the calendar day in which the 24-hour period ends.

Detected, but Not Quantified (DNQ)

Sample results that are less than the reported Minimum Level, but greater than or equal to the laboratory's MDL. Sample results reported as DNQ are estimated concentrations.

Dilution Credit

Dilution Credit is the amount of dilution granted to a discharge in the calculation of a water quality-based effluent limitation, based on the allowance of a specified mixing zone. It is calculated from the dilution ratio or determined through conducting a mixing zone study or modeling of the discharge and receiving water.

Effluent Concentration Allowance (ECA)

ECA is a value derived from the water quality criterion/objective, dilution credit, and ambient background concentration that is used, in conjunction with the coefficient of variation for the effluent monitoring data, to calculate a long-term average (LTA) discharge concentration. The ECA has the same meaning as waste load allocation (WLA) as used in U.S. EPA guidance (Technical Support Document For Water Quality-based Toxics Control, March 1991, second printing, EPA/505/2-90-001).

Enclosed Bays

Enclosed Bays means indentations along the coast that enclose an area of oceanic water within distinct headlands or harbor works. Enclosed bays include all bays where the narrowest distance between the headlands or outermost harbor works is less than 75 percent of the greatest dimension of the enclosed portion of the bay. Enclosed bays include, but are not limited to, Humboldt Bay, Bodega Harbor, Tomales Bay, Drake's Estero, San Francisco Bay, Morro Bay, Los Angeles-Long Beach Harbor, Upper and Lower Newport Bay, Mission Bay, and San Diego Bay. Enclosed bays do not include inland surface waters or ocean waters.

Estimated Chemical Concentration

The estimated chemical concentration that results from the confirmed detection of the substance by the analytical method below of the ML value.

Estuaries

Estuaries means waters, including coastal lagoons, located at the mouths of streams that serve as areas of mixing for fresh and ocean waters. Coastal lagoons and mouths of streams that are temporarily separated from the ocean by sandbars shall be considered estuaries. Estuarine waters shall be considered to extend from a bay or the open ocean to a point upstream where there is no significant mixing of fresh water and seawater. Estuarine waters included, but are not limited to, the Sacramento-San Joaquin Delta, as defined in Water Code section 12220, Suisun Bay, Carquinez Strait downstream to the Carquinez Bridge, and appropriate areas of the Smith, Mad, Eel, Noyo, Russian, Klamath, San Diego, and Otay rivers. Estuaries do not include inland surface waters or ocean waters.

Inland Surface Waters

All surface waters of the State that do not include the ocean, enclosed bays, or estuaries.

Instantaneous Maximum Effluent Limitation

The highest allowable value for any single grab sample or aliquot (i.e., each grab sample or aliquot is independently compared to the instantaneous maximum limitation).

Instantaneous Minimum Effluent Limitation

The lowest allowable value for any single grab sample or aliquot (i.e., each grab sample or aliquot is independently compared to the instantaneous minimum limitation).

Maximum Daily Effluent Limitation (MDEL)

The highest allowable daily discharge of a pollutant.

Median

The middle measurement in a set of data. The median of a set of data is found by first arranging the measurements in order of magnitude (either increasing or decreasing order). If the number of measurements (n) is odd, then the median = $X_{(n+1)/2}$. If n is even, then the median = $(X_{n/2} + X_{(n/2)+1})/2$ (i.e., the midpoint between the $n/2$ and $n/2+1$).

Method Detection Limit (MDL)

The minimum concentration of a substance that can be measured and reported with 99 percent confidence that the analyte concentration is greater than zero, as defined in 40 C.F.R. part 136, Attachment B.

Minimum Level (ML)

The concentration at which the entire analytical system must give a recognizable signal and acceptable calibration point. The ML is the concentration in a sample that is equivalent to the concentration of the lowest calibration standard analyzed by a specific analytical procedure, assuming that all the method specified sample weights, volumes, and processing steps have been followed.

Mixing Zone

Mixing Zone is a limited volume of receiving water that is allocated for mixing with a wastewater discharge where water quality criteria can be exceeded without causing adverse effects to the overall water body.

Not Detected (ND)

Those sample results less than the laboratory's MDL.

Ocean Waters

The territorial marine waters of the state as defined by California law to the extent these waters are outside of enclosed bays, estuaries, and coastal lagoons. If a discharge outside the territorial waters of the state could affect the quality of the waters of the state, the discharge may be regulated to assure no violation of the Ocean Plan will occur in ocean waters.

Persistent Pollutants

Persistent pollutants are substances for which degradation or decomposition in the environment is nonexistent or very slow.

Pollutant Minimization Program (PMP)

PMP means waste minimization and pollution prevention actions that include, but are not limited to, product substitution, waste stream recycling, alternative waste management methods, and education of the public and businesses. The goal of the PMP shall be to reduce all potential sources of a priority pollutant(s) through pollutant minimization (control) strategies, including pollution prevention measures as appropriate, to maintain the effluent concentration at or below the water quality-based effluent limitation. Pollution prevention measures may be particularly appropriate for persistent bioaccumulative priority pollutants where there is evidence that beneficial uses are being impacted. The Regional Water Board may consider cost effectiveness when establishing the requirements of a PMP. The completion and implementation of a Pollution Prevention Plan, if required pursuant to Water Code section 13263.3(d), shall be considered to fulfill the PMP requirements.

Pollution Prevention

Pollution Prevention means any action that causes a net reduction in the use or generation of a hazardous substance or other pollutant that is discharged into water and includes, but is not limited to, input change, operational improvement, production process change, and product reformulation (as defined in Water Code section 13263.3). Pollution prevention does not include actions that merely shift a pollutant in wastewater from one environmental medium to another environmental medium, unless

clear environmental benefits of such an approach are identified to the satisfaction of the State or Regional Water Board.

Reporting Level (RL)

RL is the ML (and its associated analytical method) chosen by the Discharger for reporting and compliance determination from the MLs included in this Order. The MLs included in this Order correspond to approved analytical methods for reporting a sample result that are selected by the Regional Water Board either from Appendix 4 of the SIP in accordance with section 2.4.2 of the SIP or established in accordance with section 2.4.3 of the SIP. The ML is based on the proper application of method-based analytical procedures for sample preparation and the absence of any matrix interferences. Other factors may be applied to the ML depending on the specific sample preparation steps employed. For example, the treatment typically applied in cases where there are matrix-effects is to dilute the sample or sample aliquot by a factor of ten. In such cases, this additional factor must be applied to the ML in the computation of the RL.

Source of Drinking Water

Any water designated as municipal or domestic supply (MUN) in a Regional Water Board Basin Plan.

Standard Deviation (σ)

Standard Deviation is a measure of variability that is calculated as follows:

$$\sigma = (\sum[(x - \mu)^2] / (n - 1))^{0.5}$$

where:

x is the observed value;

μ is the arithmetic mean of the observed values; and

n is the number of samples.

Toxicity Reduction Evaluation (TRE)

A study conducted in a step-wise process designed to identify the causative agents of effluent or ambient toxicity, isolate the sources of toxicity, evaluate the effectiveness of toxicity control options, and then confirm the reduction in toxicity. The first steps of the TRE consist of the collection of data relevant to the toxicity, including additional toxicity testing, and an evaluation of facility operations and maintenance practices, and best management practices. A Toxicity Identification Evaluation (TIE) may be required as part of the TRE, if appropriate. (A TIE is a set of procedures to identify the specific chemical(s) responsible for toxicity. These procedures are performed in three phases (characterization, identification, and confirmation) using aquatic organism toxicity tests.)

ATTACHMENT B – MAP

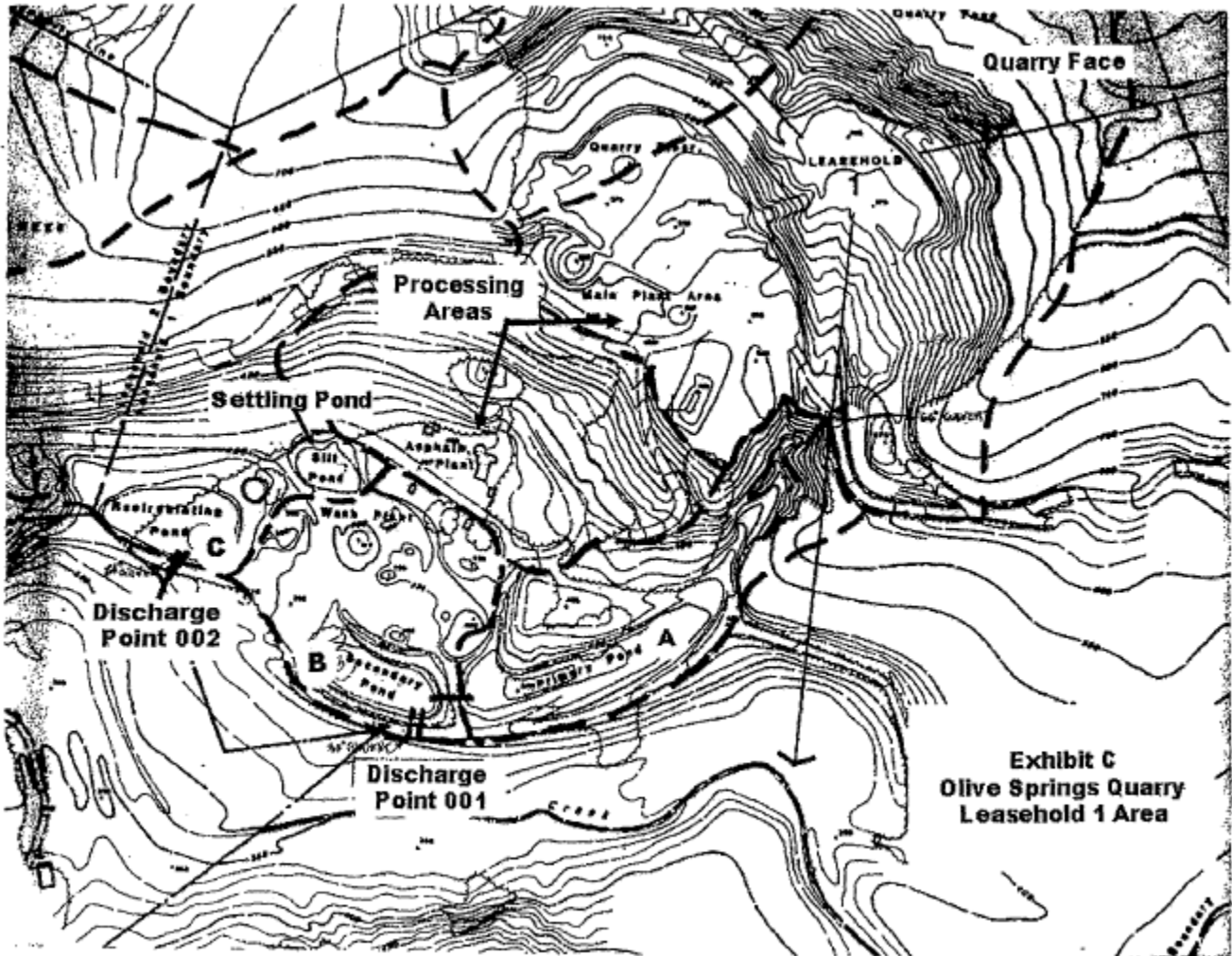

ATTACHMENT C – FLOW SCHEMATIC

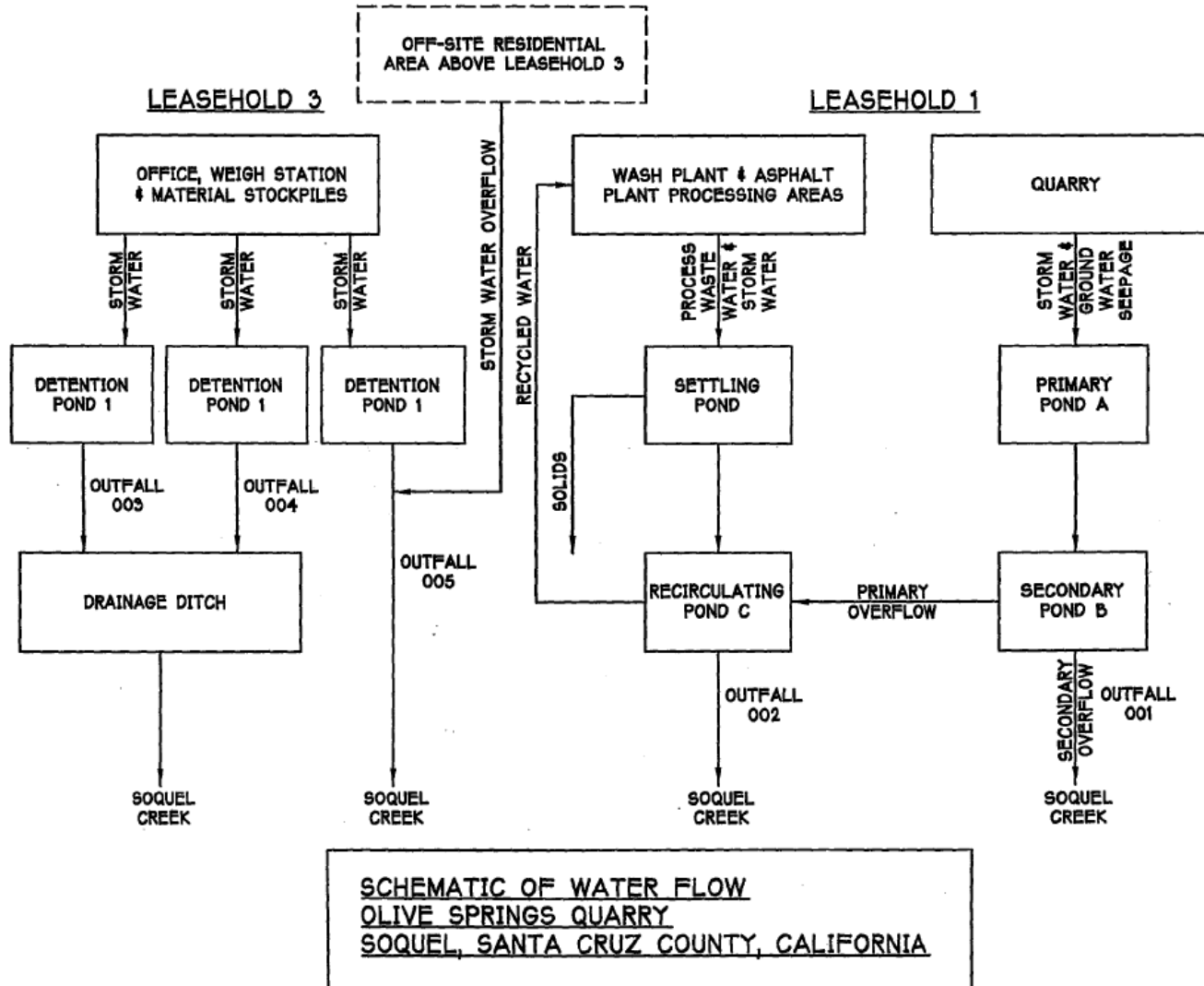

ATTACHMENT D – STANDARD PROVISIONS

I. STANDARD PROVISIONS – PERMIT COMPLIANCE

A. Duty to Comply

1. The Discharger must comply with all of the conditions of this Order. Any noncompliance constitutes a violation of the Clean Water Act (CWA) and the California Water Code and is grounds for enforcement action, for permit termination, revocation and reissuance, or modification; or denial of a permit renewal application. (40 C.F.R. § 122.41(a).)
2. The Discharger shall comply with effluent standards or prohibitions established under Section 307(a) of the CWA for toxic pollutants and with standards for sewage sludge use or disposal established under Section 405(d) of the CWA within the time provided in the regulations that establish these standards or prohibitions, even if this Order has not yet been modified to incorporate the requirement. (40 C.F.R. § 122.41(a)(1).)

B. Need to Halt or Reduce Activity Not a Defense

It shall not be a defense for a Discharger in an enforcement action that it would have been necessary to halt or reduce the permitted activity in order to maintain compliance with the conditions of this Order. (40 C.F.R. § 122.41(c).)

C. Duty to Mitigate

The Discharger shall take all reasonable steps to minimize or prevent any discharge or sludge use or disposal in violation of this Order that has a reasonable likelihood of adversely affecting human health or the environment. (40 C.F.R. § 122.41(d).)

D. Proper Operation and Maintenance

The Discharger shall at all times properly operate and maintain all facilities and systems of treatment and control (and related appurtenances) which are installed or used by the Discharger to achieve compliance with the conditions of this Order. Proper operation and maintenance also includes adequate laboratory controls and appropriate quality assurance procedures. This provision requires the operation of backup or auxiliary facilities or similar systems that are installed by a Discharger only when necessary to achieve compliance with the conditions of this Order. (40 C.F.R. § 122.41(e).)

E. Property Rights

1. This Order does not convey any property rights of any sort or any exclusive privileges. (40 C.F.R. § 122.41(g).)
2. The issuance of this Order does not authorize any injury to persons or property or invasion of other private rights, or any infringement of state or local law or regulations. (40 C.F.R. § 122.5(c).)

F. Inspection and Entry

The Discharger shall allow the Central Coast Water Board, State Water Board, U.S. EPA, and/or their authorized representatives (including an authorized contractor acting as their representative), upon the presentation of credentials and other documents, as may be required by law, to (40 C.F.R. § 122.41(i); Wat. Code, § 13383):

1. Enter upon the Discharger's premises where a regulated facility or activity is located or conducted, or where records are kept under the conditions of this Order (40 C.F.R. § 122.41(i)(1));
2. Have access to and copy, at reasonable times, any records that must be kept under the conditions of this Order (40 C.F.R. § 122.41(i)(2));
3. Inspect and photograph, at reasonable times, any facilities, equipment (including monitoring and control equipment), practices, or operations regulated or required under this Order (40 C.F.R. § 122.41(i)(3)); and
4. Sample or monitor, at reasonable times, for the purposes of assuring Order compliance or as otherwise authorized by the CWA or the Water Code, any substances or parameters at any location. (40 C.F.R. § 122.41(i)(4).)

G. Bypass

1. Definitions
 - a. "Bypass" means the intentional diversion of waste streams from any portion of a treatment facility. (40 C.F.R. § 122.41(m)(1)(i).)
 - b. "Severe property damage" means substantial physical damage to property, damage to the treatment facilities, which causes them to become inoperable, or substantial and permanent loss of natural resources that can reasonably be expected to occur in the absence of a bypass. Severe property damage does not mean economic loss caused by delays in production. (40 C.F.R. § 122.41(m)(1)(ii).)
2. Bypass not exceeding limitations. The Discharger may allow any bypass to occur which does not cause exceedances of effluent limitations, but only if it is for essential maintenance to assure efficient operation. These bypasses are not subject to the provisions listed in Standard Provisions – Permit Compliance I.G.3, I.G.4, and I.G.5 below. (40 C.F.R. § 122.41(m)(2).)
3. Prohibition of bypass. Bypass is prohibited, and the Central Coast Water Board may take enforcement action against a Discharger for bypass, unless (40 C.F.R. § 122.41(m)(4)(i)):
 - a. Bypass was unavoidable to prevent loss of life, personal injury, or severe property damage (40 C.F.R. § 122.41(m)(4)(i)(A));
 - b. There were no feasible alternatives to the bypass, such as the use of auxiliary treatment facilities, retention of untreated wastes, or maintenance during normal periods of equipment downtime. This condition is not satisfied if adequate back-up equipment should have been installed in the exercise of reasonable engineering judgment to prevent a bypass that occurred during normal periods of equipment downtime or preventive maintenance (40 C.F.R. § 122.41(m)(4)(i)(B)); and
 - c. The Discharger submitted notice to the Central Coast Water Board as required under Standard Provisions – Permit Compliance I.G.5 below. (40 C.F.R. § 122.41(m)(4)(i)(C).)
4. The Central Coast Water Board may approve an anticipated bypass, after considering its adverse effects, if the Central Coast Water Board determines that it will meet the three conditions listed in Standard Provisions – Permit Compliance I.G.3 above. (40 C.F.R. § 122.41(m)(4)(ii).)

5. Notice

- a. Anticipated bypass. If the Discharger knows in advance of the need for a bypass, it shall submit a notice, if possible at least 10 days before the date of the bypass. (40 C.F.R. § 122.41(m)(3)(i).)
- b. Unanticipated bypass. The Discharger shall submit notice of an unanticipated bypass as required in Standard Provisions - Reporting V.E below (24-hour notice). (40 C.F.R. § 122.41(m)(3)(ii).)

H. Upset

Upset means an exceptional incident in which there is unintentional and temporary noncompliance with technology based permit effluent limitations because of factors beyond the reasonable control of the Discharger. An upset does not include noncompliance to the extent caused by operational error, improperly designed treatment facilities, inadequate treatment facilities, lack of preventive maintenance, or careless or improper operation. (40 C.F.R. § 122.41(n)(1).)

1. Effect of an upset. An upset constitutes an affirmative defense to an action brought for noncompliance with such technology based permit effluent limitations if the requirements of Standard Provisions – Permit Compliance I.H.2 below are met. No determination made during administrative review of claims that noncompliance was caused by upset, and before an action for noncompliance, is final administrative action subject to judicial review. (40 C.F.R. § 122.41(n)(2).)
2. Conditions necessary for a demonstration of upset. A Discharger who wishes to establish the affirmative defense of upset shall demonstrate, through properly signed, contemporaneous operating logs or other relevant evidence that (40 C.F.R. § 122.41(n)(3)):
 - a. An upset occurred and that the Discharger can identify the cause(s) of the upset (40 C.F.R. § 122.41(n)(3)(i));
 - b. The permitted facility was, at the time, being properly operated (40 C.F.R. § 122.41(n)(3)(ii));
 - c. The Discharger submitted notice of the upset as required in Standard Provisions – Reporting V.E.2.b below (24-hour notice) (40 C.F.R. § 122.41(n)(3)(iii)); and
 - d. The Discharger complied with any remedial measures required under Standard Provisions – Permit Compliance I.C above. (40 C.F.R. § 122.41(n)(3)(iv).)
3. Burden of proof. In any enforcement proceeding, the Discharger seeking to establish the occurrence of an upset has the burden of proof. (40 C.F.R. § 122.41(n)(4).)

II. STANDARD PROVISIONS – PERMIT ACTION

A. General

This Order may be modified, revoked and reissued, or terminated for cause. The filing of a request by the Discharger for modification, revocation and reissuance, or termination, or a notification of planned changes or anticipated noncompliance does not stay any Order condition. (40 C.F.R. § 122.41(f).)

B. Duty to Reapply

If the Discharger wishes to continue an activity regulated by this Order after the expiration date of this Order, the Discharger must apply for and obtain a new permit. (40 C.F.R. § 122.41(b).)

C. Transfers

This Order is not transferable to any person except after notice to the Central Coast Water Board. The Central Coast Water Board may require modification or revocation and reissuance of the Order to change the name of the Discharger and incorporate such other requirements as may be necessary under the CWA and the Water Code. (40 C.F.R. § 122.41(l)(3); § 122.61.)

III. STANDARD PROVISIONS – MONITORING

- A.** Samples and measurements taken for the purpose of monitoring shall be representative of the monitored activity. (40 C.F.R. § 122.41(j)(1).)
- B.** Monitoring results must be conducted according to test procedures under 40 C.F.R. part 136 or, in the case of sludge use or disposal, approved under 40 C.F.R. part 136 unless otherwise specified in 40 C.F.R. part 503 unless other test procedures have been specified in this Order. (40 C.F.R. § 122.41(j)(4); § 122.44(i)(1)(iv).)

IV. STANDARD PROVISIONS – RECORDS

- A.** Except for records of monitoring information required by this Order related to the Discharger's sewage sludge use and disposal activities, which shall be retained for a period of at least five years (or longer as required by 40 C.F.R. part 503), the Discharger shall retain records of all monitoring information, including all calibration and maintenance records and all original strip chart recordings for continuous monitoring instrumentation, copies of all reports required by this Order, and records of all data used to complete the application for this Order, for a period of at least three (3) years from the date of the sample, measurement, report or application. This period may be extended by request of the Central Coast Water Board Executive Officer at any time. (40 C.F.R. § 122.41(j)(2).)

B. Records of monitoring information shall include:

- 1. The date, exact place, and time of sampling or measurements (40 C.F.R. § 122.41(j)(3)(i));
- 2. The individual(s) who performed the sampling or measurements (40 C.F.R. § 122.41(j)(3)(ii));
- 3. The date(s) analyses were performed (40 C.F.R. § 122.41(j)(3)(iii));
- 4. The individual(s) who performed the analyses (40 C.F.R. § 122.41(j)(3)(iv));
- 5. The analytical techniques or methods used (40 C.F.R. § 122.41(j)(3)(v)); and
- 6. The results of such analyses. (40 C.F.R. § 122.41(j)(3)(vi).)

C. Claims of confidentiality for the following information will be denied (40 C.F.R. § 122.7(b)):

- 1. The name and address of any permit applicant or Discharger (40 C.F.R. § 122.7(b)(1)); and
- 2. Permit applications and attachments, permits and effluent data. (40 C.F.R. § 122.7(b)(2).)

V. STANDARD PROVISIONS – REPORTING

A. Duty to Provide Information

The Discharger shall furnish to the Central Coast Water Board State Water Board, or U.S. EPA within a reasonable time, any information which the Central Coast Water Board, State Water Board, or U.S. EPA may request to determine whether cause exists for modifying, revoking and reissuing, or terminating this Order or to determine compliance with this Order. Upon request, the Discharger shall also furnish to the Central Coast Water Board, State Water Board, or U.S. EPA copies of records required to be kept by this Order. (40 C.F.R. § 122.41(h); Wat. Code, § 13267.)

B. Signatory and Certification Requirements

1. All applications, reports, or information submitted to the Central Coast Water Board, State Water Board, and/or U.S. EPA shall be signed and certified in accordance with Standard Provisions – Reporting V.B.2, V.B.3, V.B.4, and V.B.5 below. (40 C.F.R. § 122.41(k).)
2. All permit applications shall be signed by either a principal executive officer or ranking elected official. For purposes of this provision, a principal executive officer of a federal agency includes: (i) the chief executive officer of the agency, or (ii) a senior executive officer having responsibility for the overall operations of a principal geographic unit of the agency (e.g., Regional Administrators of U.S. EPA). (40 C.F.R. § 122.22(a)(3).)
3. All reports required by this Order and other information requested by the Central Coast Water Board, State Water Board, or U.S. EPA shall be signed by a person described in Standard Provisions – Reporting V.B.2 above, or by a duly authorized representative of that person. A person is a duly authorized representative only if:
 - a. The authorization is made in writing by a person described in Standard Provisions – Reporting V.B.2 above (40 C.F.R. § 122.22(b)(1));
 - b. The authorization specifies either an individual or a position having responsibility for the overall operation of the regulated facility or activity such as the position of plant manager, operator of a well or a well field, superintendent, position of equivalent responsibility, or an individual or position having overall responsibility for environmental matters for the company. (A duly authorized representative may thus be either a named individual or any individual occupying a named position.) (40 C.F.R. § 122.22(b)(2)); and
 - c. The written authorization is submitted to the Central Coast Water Board and State Water Board. (40 C.F.R. § 122.22(b)(3).)
4. If an authorization under Standard Provisions – Reporting V.B.3 above is no longer accurate because a different individual or position has responsibility for the overall operation of the facility, a new authorization satisfying the requirements of Standard Provisions – Reporting V.B.3 above must be submitted to the Central Coast Water Board and State Water Board prior to or together with any reports, information, or applications, to be signed by an authorized representative. (40 C.F.R. § 122.22(c).)
5. Any person signing a document under Standard Provisions – Reporting V.B.2 or V.B.3 above shall make the following certification:

“I certify under penalty of law that this document and all attachments were prepared under my direction or supervision in accordance with a system designed to assure that qualified personnel properly gather and evaluate the information submitted. Based on

my inquiry of the person or persons who manage the system or those persons directly responsible for gathering the information, the information submitted is, to the best of my knowledge and belief, true, accurate, and complete. I am aware that there are significant penalties for submitting false information, including the possibility of fine and imprisonment for knowing violations.” (40 C.F.R. § 122.22(d).)

C. Monitoring Reports

1. Monitoring results shall be reported at the intervals specified in the Monitoring and Reporting Program (Attachment E) in this Order. (40 C.F.R. § 122.41(l)(4).)
2. Monitoring results must be reported on a Discharge Monitoring Report (DMR) form or forms provided or specified by the Central Coast Water Board or State Water Board for reporting results of monitoring of sludge use or disposal practices. (40 C.F.R. § 122.41(l)(4)(i).)
3. If the Discharger monitors any pollutant more frequently than required by this Order using test procedures approved under 40 C.F.R. part 136, or another method required for an industry-specific waste stream under 40 C.F.R. subchapters N or O, the results of such monitoring shall be included in the calculation and reporting of the data submitted in the DMR or sludge reporting form specified by the Central Coast Water Board. (40 C.F.R. § 122.41(l)(4)(ii).)
4. Calculations for all limitations, which require averaging of measurements, shall utilize an arithmetic mean unless otherwise specified in this Order. (40 C.F.R. § 122.41(l)(4)(iii).)

D. Compliance Schedules

Reports of compliance or noncompliance with, or any progress reports on, interim and final requirements contained in any compliance schedule of this Order, shall be submitted no later than 14 days following each schedule date. (40 C.F.R. § 122.41(l)(5).)

E. Twenty-Four Hour Reporting

1. The Discharger shall report any noncompliance that may endanger health or the environment. Any information shall be provided orally within 24 hours from the time the Discharger becomes aware of the circumstances. A written submission shall also be provided within five (5) days of the time the Discharger becomes aware of the circumstances. The written submission shall contain a description of the noncompliance and its cause; the period of noncompliance, including exact dates and times, and if the noncompliance has not been corrected, the anticipated time it is expected to continue; and steps taken or planned to reduce, eliminate, and prevent reoccurrence of the noncompliance. (40 C.F.R. § 122.41(l)(6)(i).)
2. The following shall be included as information that must be reported within 24 hours under this paragraph (40 C.F.R. § 122.41(l)(6)(ii)):
 - a. Any unanticipated bypass that exceeds any effluent limitation in this Order. (40 C.F.R. § 122.41(l)(6)(ii)(A).)
 - b. Any upset that exceeds any effluent limitation in this Order. (40 C.F.R. § 122.41(l)(6)(ii)(B).)
3. The Central Coast Water Board may waive the above-required written report under this provision on a case-by-case basis if an oral report has been received within 24 hours. (40 C.F.R. § 122.41(l)(6)(iii).)

F. Planned Changes

The Discharger shall give notice to the Central Coast Water Board as soon as possible of any planned physical alterations or additions to the permitted facility. Notice is required under this provision only when (40 C.F.R. § 122.41(l)(1)):

1. The alteration or addition to a permitted facility may meet one of the criteria for determining whether a facility is a new source in section 122.29(b) (40 C.F.R. § 122.41(l)(1)(i)); or
2. The alteration or addition could significantly change the nature or increase the quantity of pollutants discharged. This notification applies to pollutants that are subject neither to effluent limitations in this Order nor to notification requirements under section 122.42(a)(1) (see Additional Provisions—Notification Levels VII.A.1). (40 C.F.R. § 122.41(l)(1)(ii).)
3. The alteration or addition results in a significant change in the Discharger's sludge use or disposal practices, and such alteration, addition, or change may justify the application of permit conditions that are different from or absent in the existing permit, including notification of additional use or disposal sites not reported during the permit application process or not reported pursuant to an approved land application plan. (40 C.F.R. § 122.41(l)(1)(iii).)

G. Anticipated Noncompliance

The Discharger shall give advance notice to the Central Coast Water Board or State Water Board of any planned changes in the permitted facility or activity that may result in noncompliance with this Order's requirements. (40 C.F.R. § 122.41(l)(2).)

H. Other Noncompliance

The Discharger shall report all instances of noncompliance not reported under Standard Provisions – Reporting V.C, V.D, and V.E above at the time monitoring reports are submitted. The reports shall contain the information listed in Standard Provision – Reporting V.E above. (40 C.F.R. § 122.41(l)(7).)

I. Other Information

When the Discharger becomes aware that it failed to submit any relevant facts in a permit application, or submitted incorrect information in a permit application or in any report to the Central Coast Water Board, State Water Board, or U.S. EPA, the Discharger shall promptly submit such facts or information. (40 C.F.R. § 122.41(l)(8).)

VI. STANDARD PROVISIONS – ENFORCEMENT

The Central Coast Water Board is authorized to enforce the terms of this permit under several provisions of the Water Code, including, but not limited to, sections 13385, 13386, and 13387.

VII. ADDITIONAL PROVISIONS – NOTIFICATION LEVELS

A. Publicly-Owned Treatment Works (POTWs)

All POTWs shall provide adequate notice to the Central Coast Water Board of the following (40 C.F.R. § 122.42(b)):

1. Any new introduction of pollutants into the POTW from an indirect discharger that would be subject to sections 301 or 306 of the CWA if it were directly discharging those pollutants (40 C.F.R. § 122.42(b)(1)); and

2. Any substantial change in the volume or character of pollutants being introduced into that POTW by a source introducing pollutants into the POTW at the time of adoption of the Order. (40 C.F.R. § 122.42(b)(2).)
3. Adequate notice shall include information on the quality and quantity of effluent introduced into the POTW as well as any anticipated impact of the change on the quantity or quality of effluent to be discharged from the POTW. (40 C.F.R. § 122.42(b)(3).)

VIII. CENTRAL COAST WATER BOARD STANDARD PROVISIONS

A. Central Coast Standard Provision – Prohibitions

1. Introduction of “incompatible wastes” to the treatment system is prohibited.
2. Discharge of high-level radiological waste and of radiological, chemical, and biological warfare agents is prohibited.
3. Discharge of “toxic pollutants” in violation of effluent standards and prohibitions established under section 307(a) of the Clean Water Act (CWA) is prohibited.
4. Discharge of sludge, sludge digester or thickener supernatant, and sludge drying bed leachate to drainageways, surface waters, or the ocean is prohibited.
5. Introduction of pollutants into the collection, treatment, or disposal system by and “indirect discharger” that:
 - a. Inhibit or disrupt the treatment process, system operation, or the eventual use or disposal of sludge; or,
 - b. Flow through the system to the receiving water untreated; and,
 - c. Cause or “significantly contribute” to a violation of any requirement of this Order, is prohibited.
6. Introduction of “pollutant free” wastewater to the collection, treatment, and disposal system in amounts that threaten compliance with this order is prohibited.

B. Central Coast Standard Provision – Provisions

1. Collection, treatment, and discharge of waste shall not create a nuisance or pollution, as defined by California Water Code (CWC) 13050.
2. All facilities used for transport or treatment of wastes shall be adequately protected from inundation and washout as the result of a 100-year frequency flood.
3. Operation of collection, treatment, and disposal systems shall be in a manner that precludes public contact with wastewater.
4. Collected screenings, sludges, and other solids removed from liquid wastes shall be disposed in a manner approved by the Executive Officer.
5. Publicly owned wastewater treatment plans shall be supervised and operated by persons possessing certificates of appropriate grade pursuant to Title 23 of the California Administrative Code.
6. After notice and opportunity for a hearing, this order may be terminated for cause, including, but not limited to:
 - a. Violation of any term or condition contained in this order;

- b. Obtaining this order by misrepresentation, or by failure to disclose fully all relevant facts;
 - c. A change in any condition or endangerment to human health or environment that requires a temporary or permanent reduction or elimination of the authorized discharge; and,
 - d. A substantial change in character, location, or volume of the discharge.
7. Provisions of this permit are severable. If any provision of the permit is found invalid, the remainder of the permit shall not be affected.
8. After notice and opportunity for hearing, this order may be modified or revoked and reissued for cause, including:
 - a. Promulgation of a new or revised effluent standard or limitation;
 - b. A material change in character, location, or volume of the discharge;
 - c. Access to new information that affects the terms of the permit, including applicable schedules;
 - d. Correction of technical mistakes or mistaken interpretations of law; and,
 - e. Other causes set forth under Sub-part D of 40 CFR Part 122.
9. Safeguards shall be provided to ensure maximal compliance with all terms and conditions of this permit. Safeguards shall include preventative and contingency plans and may also include alternative power sources, stand-by generators, retention capacity, operative procedures, or other precautions. Preventative and contingency plans for controlling and minimizing the effect of accidental discharges shall:
 - a. Identify possible situations that could cause "upset," "overflow," or "bypass," or other noncompliance. (Loading and storage areas, power outage, waste treatment unit outage, and failure of process equipment, tanks and pipes should be considered).
 - b. Evaluate the effectiveness of present facilities and procedures and describe procedures and steps to minimize or correct any adverse environmental impact resulting from noncompliance with the permit.
10. Physical Facilities shall be designed and constructed according to accepted engineering practice and shall be capable of full compliance with this order when properly operated and maintained. Proper operation and maintenance shall be described in an Operation and Maintenance Manual. Facilities shall be accessible during the wet-weather season.
11. The discharger shall at all times properly operate and maintain all facilities and systems of treatment and control (and related appurtenances) that are installed or used by the discharger to achieve compliance with the conditions of this order. Electrical and mechanical equipment shall be maintained in accordance with appropriate practices and standards, such as NFPA 70B, *Recommended Practice for Electrical Equipment Maintenance*; NFPA 70E, *Standard for Electrical Safety in the Workplace*; ANSI/NETA MTS *Standard for Maintenance: Testing Specifications for Electrical Power Equipment and Systems*, or procedures established by insurance companies or industry resources.
12. If the discharger's facilities are equipped with SCADA or other systems that implement wireless, remote operation, the discharger should implement appropriate safeguards against unauthorized access to the wireless systems. Standards such as NIST SP 800-

53, *Recommended Security Controls for Federal Information Systems*, can provide guidance.

13. Production and use of reclaimed water is subject to the approval of the Central Coast Board. Production and use of reclaimed water shall be in conformance with reclamation criteria established in Chapter 3, Title 22, of the California Administrative Code and Chapter 7, Division 7, of the CWC. An engineering report pursuant to section 60323, Title 22, of the California Administrative Code is required and a waiver or water reclamation requirements from the Central Coast Board is required before reclaimed water is supplied for any use, or to any user, not specifically identified and approved either in this Order or another order issued by this Board.

C. Central Coast Standard Provisions – General Monitoring Requirements

1. If results of monitoring a pollutant appear to violate effluent limitations based on a weekly, monthly, 30-day, or six-month period, but compliance or non-compliance cannot be validated because sampling is too infrequent, the frequency of sampling shall be increased to validate the test within the next monitoring period. The increased frequency shall be maintained until the Executive Officer agrees the original monitoring frequency may be resumed.

For example, if copper is monitored annually and results exceed the six-month median numerical effluent limitation in the permit, monitoring of copper must be increased to a frequency of at least once every two months (Central Coast Standard Provisions – Definitions I.G.13.). If suspended solids are monitored weekly and results exceed the weekly average numerical limit in the permit, monitoring of suspended solids must be increased to at least four (4) samples every week (Central Coast Standard Provisions – Definitions I.G.14.).

2. Water quality analyses performed in order to monitor compliance with this permit shall be by a laboratory certified by the State Department of Health Services (DHS) for the constituent(s) being analyzed. Bioassay(s) performed in order to monitor compliance with this permit shall be in accord with guidelines approved by the State Water Resources Control Board (State Water Board) and the State Department of Fish and Game. If the laboratory used or proposed for use by the discharger is not certified by the DHS or, where appropriate, the Department of Fish and Game due to restrictions in the State's laboratory certification program, the discharger shall be considered in compliance with this provision provided:
 - a. Data results remain consistent with results of samples analyzed by the Central Coast Water Board;
 - b. A quality assurance program is used at the laboratory, including a manual containing steps followed in this program that is available for inspections by the staff of the Central Coast Water Board; and,
 - c. Certification is pursued in good faith and obtained as soon as possible after the program is reinstated.
3. Samples and measurements taken for the purpose of monitoring shall be representative of the monitored activity. Samples shall be taken during periods of peak loading conditions. Influent samples shall be samples collected from the combined flows of all incoming wastes, excluding recycled wastes. Effluent samples shall be samples collected downstream of the last treatment unit and tributary flow and upstream of any mixing with receiving waters.

4. All monitoring instruments and devices used by the discharger to fulfill the prescribed monitoring program shall be properly maintained and calibrated as necessary to ensure their continued accuracy.

D. Central Coast Standard Provisions – General Reporting Requirements

1. Reports of marine monitoring surveys conducted to meet receiving water monitoring requirements of the Monitoring and Reporting Program shall include at least the following information:
 - a. A description of climatic and receiving water characteristics at the time of sampling (weather observations, floating debris, discoloration, wind speed and direction, swell or wave action, time of sampling, tide height, etc.).
 - b. A description of sampling stations, including differences unique to each station (e.g., station location, grain size, rocks, shell litter, calcareous worm tubes, evident life, etc.).
 - c. A description of the sampling procedures and preservation sequence used in the survey.
 - d. A description of the exact method used for laboratory analysis. In general, analysis shall be conducted according to Central Coast Standard Provisions – C.1 above, and Federal Standard Provision – Monitoring III.B. However, variations in procedure are acceptable to accommodate the special requirements of sediment analysis. All such variations must be reported with the test results.
 - e. A brief discussion of the results of the survey. The discussion shall compare data from the control station with data from the outfall stations. All tabulations and computations shall be explained.
2. Reports of compliance or noncompliance with, or any progress reports on, interim and final requirements contained in any compliance schedule shall be submitted within 14 days following each scheduled date unless otherwise specified within the permit. If reporting noncompliance, the report shall include a description of the reason, a description and schedule of tasks necessary to achieve compliance, and an estimated date for achieving full compliance. A second report shall be submitted within 14 days of full compliance.
3. The “Discharger” shall file a report of waste discharge or secure a waiver from the Executive Officer at least 180 days before making any material change or proposed change in the character, location, or plume of the discharge.
4. Within 120 days after the discharger discovers, or is notified by the Central Coast Water Board, that monthly average daily flow will or may reach design capacity of waste treatment and/or disposal facilities within four (4) years, the discharger shall file a written report with the Central Coast Water Board. The report shall include:
 - a. the best estimate of when the monthly average daily dry weather flow rate will equal or exceed design capacity; and,
 - b. a schedule for studies, design, and other steps needed to provide additional capacity for waste treatment and/or disposal facilities before the waste flow rate equals the capacity of present units.
 - c. In addition to complying with Federal Standard Provision – Reporting V.B., the required technical report shall be prepared with public participation and reviewed, approved and jointly submitted by all planning and building departments having

jurisdiction in the area served by the waste collection, treatment, or disposal facilities.

5. All "Dischargers" shall submit reports electronically to the:

California Regional Water Quality Control Board
Central Coast Region
centralcoast@waterboards.ca.gov
895 Aerovista Place, Suite 101
San Luis Obispo, CA 93401-7906

In addition, "Dischargers" with designated major discharges shall submit a copy of each document to:

Regional Administrator
U.S. EPA, Region 9
Attention: CWA Standards and Permits Office (WTR-5)
75 Hawthorne Street
San Francisco, California 94105

6. Transfer of control or ownership of a waste discharge facility must be preceded by a notice to the Central Coast Water Board at least 30 days in advance of the proposed transfer date. The notice must include a written agreement between the existing "Discharger" and proposed "Discharger" containing specific date for transfer of responsibility, coverage, and liability between them. Whether a permit may be transferred without modification or revocation and reissuance is at the discretion of the Board. If permit modification or revocation and reissuance is necessary, transfer may be delayed 180 days after the Central Coast Water Board's receipt of a complete permit application. Please also see Federal Standard Provision – Permit Action II.C.
7. Except for data determined to be confidential under CWA §308 (excludes effluent data and permit applications), all reports prepared in accordance with this permit shall be available for public inspection at the office of the Central Coast Water Board or Regional Administrator of U.S. EPA. Please also see Federal Standard Provision – Records IV.C.
8. By January 30 of each year, the discharger shall submit an annual report to the Central Coast Water Board. The report shall contain the following:
- a. Both tabular and graphical summaries of the monitoring data obtained during the previous year.
 - b. A discussion of the previous year's compliance record and corrective actions taken, or which may be needed, to bring the discharger into full compliance.
 - c. An evaluation of wastewater flows with projected flow rate increases over time and the estimated date when flows will reach facility capacity.
 - d. A discussion of operator certification and a list of current operating personnel and their grades of certification.
 - e. The date of the facility's Operation and Maintenance Manual (including contingency plans as described in Provision B.9), the date the manual was last reviewed, and whether the manual is complete and valid for the current facility.
 - f. A discussion of the laboratories used by the discharger to monitor compliance with effluent limits and a summary of performance relative to Section C, General Monitoring Requirements.

If the facility treats industrial or domestic wastewater and there is no provision for periodic sludge monitoring in the Monitoring and Reporting Program, the report shall include a summary of sludge quantities, analyses of its chemical and moisture content, and its ultimate destination.

If appropriate, the report shall also evaluate the effectiveness of the local source control or pretreatment program using the State Water Resources Control Board's "Guidelines for Determining the Effectiveness of Local Pretreatment Program."

E. Central Coast Standard Provisions – General Pretreatment Provisions

1. Discharge of pollutants by "indirect dischargers" in specific industrial sub-categories (appendix C, 40 CFR Part 403), where categorical pretreatment standards have been established, or are to be established, (according to 40 CFR Chapter 1, Subchapter N), shall comply with the appropriate pretreatment standards:
 - a. By the date specified therein;
 - b. Within three (3) years of the effective date specified therein, but in no case later than July 1, 1984; or,
 - c. If a new indirect discharger, upon commencement of discharge

F. Central Coast Standard Provision – Enforcement

1. Any person failing to file a report of waste discharge or other report as required by this permit shall be subject to a civil penalty not to exceed \$5,000 per day.
2. Upon reduction, loss, or failure of the treatment facility, the "Discharger" shall, to the extent necessary to maintain compliance with this permit, control production or all discharges, or both, until the facility is restored or an alternative method of treatment is provided.

G. Central Coast Standard Provisions – Definitions (Not otherwise included in Attachment A to this Order)

1. A "composite sample" is a combination of no fewer than eight (8) individual samples obtained at equal time intervals (usually hourly) over the specified sampling (composite) period. The volume of each individual sample is proportional to the flow rate at the time of sampling. The period shall be specified in the Monitoring and Reporting Program ordered by the Executive Officer.
2. "Daily Maximum" limit means the maximum acceptable concentration or mass emission rate of a pollutant measured during a calendar day or during any 24-hour period reasonably representative of the calendar day for purposes of sampling. It is normally compared with results based on "composite samples" except for ammonia, total chlorine, phenolic compounds, and toxicity concentration. For all exceptions, comparisons will be made with results from a "grab sample".
3. "Discharger", as used herein, means, as appropriate: (1) the Discharger, (2) the local sewerage entity (when the collection system is not owned and operated by the Discharger), or (3) "indirect discharger" (where "Discharger" appears in the same paragraph as "indirect discharger", it refers to the discharger.)
4. "Duly Authorized Representative" is one where:
 - a. the authorization is made in writing by a person described in the signatory paragraph of Federal Standard Provision V.B.;

- b. the authorization specifies either an individual or the occupant of a position having either responsibility for the overall operation of the regulated facility, such as the plant manager, or overall responsibility for environmental matters of the company; and,
 - c. the written authorization was submitted to the Central Coast Water Board.
5. A "grab sample" is defined as any individual sample collected in less than 15 minutes. "Grab samples" shall be collected during peak loading conditions, which may or may not be during hydraulic peaks. It is used primarily in determining compliance with the daily maximum limits identified in Central Coast Standard Provision – Provision G.2. and instantaneous maximum limits.
6. "Hazardous substance" means any substance designated under 40 CFR Part 116 pursuant to Section 311 of the Clean Water Act.
7. "Incompatible wastes" are:
- a. Wastes which create a fire or explosion hazard in the treatment works;
 - b. Wastes which will cause corrosive structural damage to treatment works, but in no case wastes with a pH lower than 5.0 unless the works is specifically designed to accommodate such wastes;
 - c. Solid or viscous wastes in amounts which cause obstruction to flow in sewers, or which cause other interference with proper operation of treatment works;
 - d. Any waste, including oxygen demanding pollutants (BOD₅, etc), released in such volume or strength as to cause inhibition or disruption in the treatment works and subsequent treatment process upset and loss of treatment efficiency; and,
 - e. Heat in amounts that inhibit or disrupt biological activity in the treatment works or that raise influent temperatures above 40°C (104°F) unless the treatment works is designed to accommodate such heat.
8. "Indirect Discharger" means a non-domestic discharger introducing pollutants into a publicly owned treatment and disposal system.
9. "Log Mean" is the geometric mean. Used for determining compliance of fecal or total coliform populations, it is calculated with the following equation:

$$\text{Log Mean} = (C_1 \times C_2 \times \dots \times C_n)^{1/n},$$

in which "n" is the number of days samples were analyzed during the period and any "C" is the concentration of bacteria (MPN/100 ml) found on each day of sampling. "n" should be five or more.

10. "Mass emission rate" is a daily rate defined by the following equations:

$$\text{mass emission rate (lbs/day)} = 8.34 \times Q \times C; \text{ and,}$$

$$\text{mass emission rate (kg/day)} = 3.79 \times Q \times C,$$

where "C" (in mg/L) is the measured daily constituent concentration or the average of measured daily constituent concentrations and "Q" (in MGD) is the measured daily flowrate or the average of measured daily flow rates over the period of interest.

11. The "Maximum Allowable Mass Emission Rate," whether for a month, week, day, or six-month period, is a daily rate determined with the formulas in paragraph G.10, above, using the effluent concentration limit specified in the permit for the period and the average of measured daily flows (up to the allowable flow) over the period.
12. "Maximum Allowable Six-Month Median Mass Emission Rate" is a daily rate determined with the formulas in Central Coast Standard Provision – Provision G.10, above, using the "six-month Median" effluent limit specified in the permit, and the average of measured daily flows (up to the allowable flow) over a 180-day period.
13. "Median" is the value below which half the samples (ranked progressively by increasing value) fall. It may be considered the middle value, or the average of two middle values.
14. "Monthly Average" (or "Weekly Average", as the case may be) is the arithmetic mean of daily concentrations or of daily mass emission rates over the specified 30-day (or 7-day) period.

$$\text{Average} = (X_1 + X_2 + \dots + X_n) / n$$

in which "n" is the number of days samples were analyzed during the period and "X" is either the constituent concentration (mg/l) or mass emission rate (kg/day or lbs/day) for each sampled day. "n" should be four or greater.

15. "Municipality" means a city, town, borough, county, district, association, or other public body created by or under State law and having jurisdiction over disposal of sewage, industrial waste, or other waste.
16. "Overflow" means the intentional or unintentional diversion of flow from the collection and transport systems, including pumping facilities.
17. "Pollutant-free wastewater" means inflow and infiltration, stormwaters, and cooling waters and condensates which are essentially free of pollutants.
18. "Primary Industry Category" means any industry category listed in 40 CFR Part 122, Appendix A.
19. "Removal Efficiency" is the ratio of pollutants removed by the treatment unit to pollutants entering the treatment unit. Removal efficiencies of a treatment plant shall be determined using "Monthly averages" of pollutant concentrations (C, in mg/l) of influent and effluent samples collected about the same time and the following equation (or its equivalent):
$$C_{\text{Effluent}} \text{ Removal Efficiency (\%)} = 100 \times (1 - C_{\text{effluent}} / C_{\text{influent}})$$
20. "Severe property damage" means substantial physical damage to property, damage to treatment facilities which causes them to become inoperable, or substantial and permanent loss to natural resources which can reasonably be expected to occur in the absence of a "bypass". It does not mean economic loss caused by delays in production.
21. "Sludge" means the solids, residues, and precipitates separated from, or created in, wastewater by the unit processes of a treatment system.
22. To "significantly contribute" to a permit violation means an "indirect discharger" must:
 - a. Discharge a daily pollutant loading in excess of that allowed by contract with the "Discharger" or by Federal, State, or Local law;

- b. Discharge wastewater which substantially differs in nature or constituents from its average discharge;
 - c. Discharge pollutants, either alone or in conjunction with discharges from other sources, which results in a permit violation or prevents sewage sludge use or disposal; or
 - d. Discharge pollutants, either alone or in conjunction with pollutants from other sources that increase the magnitude or duration of permit violations.
23. "Toxic Pollutant" means any pollutant listed as toxic under Section 307 (a)(1) of the Clean Water Act or under 40 CFR Part 122, Appendix D. Violation of maximum daily discharge limitations are subject to 24-hour reporting (Federal Standard Provisions V.E.).
24. "Zone of Initial Dilution" means the region surrounding or adjacent to the end of an outfall pipe or diffuser ports whose boundaries are defined through calculation of a plume model verified by the State Water Board

ATTACHMENT E – MONITORING AND REPORTING PROGRAM

Contents

| | | |
|-------|---|-----|
| I. | General Monitoring Provisions | E-2 |
| II. | Monitoring Locations..... | E-3 |
| III. | Influent Monitoring Requirements – Not Applicable..... | E-3 |
| IV. | Effluent Monitoring Requirements | E-3 |
| V. | Whole Effluent Toxicity Testing Requirements..... | E-4 |
| VI. | Land Discharge Monitoring Requirements – Not Applicable..... | E-8 |
| VII. | Reclamation Monitoring Requirements – Not Applicable..... | E-8 |
| VIII. | Receiving Water Monitoring Requirements – Surface Water | E-8 |
| IX. | Biosolids Monitoring – Not Applicable..... | E-8 |
| X. | Other Monitoring Requirements – Not Applicable | E-8 |
| XI. | Reporting Requirements..... | E-9 |

Tables

| | | |
|------------|---|-----|
| Table E-1. | Monitoring Station Locations | E-3 |
| Table E-2. | Effluent Monitoring..... | E-4 |
| Table E-3. | Receiving Water Monitoring Requirements..... | E-8 |
| Table E-4. | Monitoring Periods and Reporting Schedule | E-9 |

ATTACHMENT E – MONITORING AND REPORTING PROGRAM (MRP)

The Code of Federal Regulations (40 C.F.R. § 122.48) requires that all NPDES permits specify monitoring and reporting requirements. Water Code sections 13267 and 13383 also authorize the Regional Water Quality Control Board (Central Coast Water Board) to require technical and monitoring reports. This MRP establishes monitoring and reporting requirements that implement federal and California regulations.

I. GENERAL MONITORING PROVISIONS

- A.** Laboratories analyzing monitoring samples shall be certified by the Department of Public Health (DPH), in accordance with the provision of Water Code section 13176, and must include quality assurance/quality control data with their reports.
- B.** Samples and measurements taken as required herein shall be representative of the volume and nature of the monitored discharge. All samples shall be taken at the monitoring locations specified below and, unless otherwise specified, before the monitored flow joins or is diluted by any other waste stream, body of water, or substance. Monitoring locations shall now be changed without notification to and approval of the Central Coast Water Board.
- C.** Appropriate flow measurement devices and methods consistent with accepted scientific practices shall be selected and used to ensure the accuracy and reliability of measurements of the volume of monitored discharges. The devices shall be installed, calibrated, and maintained to ensure that the accuracy of the measurements is consistent with the accepted capability of that type of device. Devices selected shall be capable of measuring flows with a maximum deviation of less than ± 10 percent from true discharge rates throughout the range of expected discharge volumes. Guidance in selection, installation, calibration, and operation of acceptable flow measurement devices can be obtained from the following references.
 - 1. *A Guide to Methods and Standards for the Measurement of Water Flow*, U.S. Department of Commerce, National Bureau of Standards, NBS Special Publication 421, May 1975, 96 pp. (Available from the U.S. Government Printing Office, Washington, D.C. 20402. Order by SD Catalog No. C13.10:421.)
 - 2. *Water Measurement Manual*, U.S. Department of Interior, Bureau of Reclamation, Second Edition, Revised Reprint, 1974, 327 pp. (Available from the U.S. Government Printing Office, Washington D.C. 20402. Order by Catalog No. 172.19/2:W29/2, Stock No. S/N 24003-0027.)
 - 3. *Flow Measurement in Open Channels and Closed Conduits*, U.S. Department of Commerce, National Bureau of Standards, NBS Special Publication 484, October 1977, 982 pp. (Available in paper copy or microfiche from National Technical Information Services (NTIS) Springfield, VA 22050. Order by NTIS No. PB-273 535/5ST.)
 - 4. *NPDES Compliance Sampling Manual*, U.S. Environmental Protection Agency, Office of Water Enforcement, Publication MCD-51, 1977, 140 pp. (Available from the General Services Administration (8FFS), Centralized Mailing Lists Services, Building 41, Denver Federal Center, CO 80225.)
- D.** All monitoring instruments and devices used by the Discharger to fulfill the prescribed monitoring program shall be properly maintained and calibrated as necessary to ensure their continued accuracy. All flow measurement devices shall be calibrated at least once per year to ensure continued accuracy of the devices.

- E. Monitoring results, including noncompliance, shall be reported at intervals and in a manner specified in this MRP.
- F. Unless otherwise specified by this MRP, all monitoring shall be conducted according to test procedures established at 40 C.F.R. 136, Guidelines Establishing Test Procedures for Analysis of Pollutants. All analyses shall be conducted using the lowest practical quantitation limit achievable using the specified methodology. For priority pollutants, the methods must meet the lowest Minimum Levels (MLs) specified in Attachment 4 of the SIP. If no methods are specified for a given pollutant it shall be analyzed by methods approved by this Regional Water Board or the State Water Board. If more than one analytical test method is listed for a given parameter, the Discharger must select from the listed methods and corresponding MLs.
- G. Monitoring and sampling periods are defined as follows unless otherwise specified in this MRP:
 - Daily:** Midnight through 11:59 PM, or any 24-hour period that reasonably represents a calendar day for purposes of sampling.
 - Weekly:** Sunday through Saturday (Note: For weekly monitoring and sampling periods that start in one monthly reporting period but end in the next, the Discharger may report the weekly data in the monthly monitoring report containing the last day of the weekly period.)
 - Monthly:** 1st day of calendar month through last day of calendar month.
 - Annually:** January 1st through December 31st

II. MONITORING LOCATIONS

The Discharger shall establish the following monitoring locations to demonstrate compliance with the effluent limitations, discharge specifications, and other requirements in this Order:

Table E-1. Monitoring Station Locations

| Discharge Point Name | Monitoring Location Name | Monitoring Location Description (include Latitude and Longitude when available) |
|----------------------|--------------------------|--|
| 002 | EFF-002 | Pond C at the discharge point to Soquel Creek. Latitude: 37°03'30" N, Longitude: 121°55'15"W |
| -- | RSW-001 | In Soquel Creek, upstream of Discharge Point No. 002, where a representative sample for determination of background water quality can be taken. |
| -- | RSW-002 | In Soquel Creek, downstream of Discharge Point No. 002, where a representative sample for determination of impacts to receiving water quality due to discharges from Discharge Point No. 002 can be taken. |

III. INFLUENT MONITORING REQUIREMENTS – NOT APPLICABLE

IV. EFFLUENT MONITORING REQUIREMENTS

A. Monitoring Location EFF-001

1. The Discharger shall monitor effluent at Monitoring Location EFF-002 as follows. Monitoring is required only when effluent is being discharged to the receiving water. If no discharge occurs within the sampling interval specified below, samples shall be collected

at the first discharge event following the specified interval and at the specified sampling frequency thereafter.

Table E-2. Effluent Monitoring

| Parameter | Units | Sample Type | Minimum Sampling Frequency |
|--|----------------|-------------|-------------------------------------|
| Flow | MGD | Measured | 1/Day |
| Total Suspended Solids (TSS) | mg/L | Grab | 1/Week ^[1] |
| Settleable Solids | mL/L | Grab | 1/Week ^[1] |
| Turbidity | NTUs | Grab | 1/Week ^[1] |
| pH | standard units | Grab | 1/Week ^[1] |
| Temperature | °F | Grab | 1/Week ^[1] |
| Chronic Toxicity ^[2] | Pass/Fail | Grab | Once per 2 Years ^{[1] [3]} |
| Aluminum, Total Recoverable | µg/L | Grab | Once per 2 Years ^{[1] [3]} |
| Arsenic, Total Recoverable | µg/L | Grab | Once per 2 Years ^{[1] [3]} |
| Barium, Total Recoverable | µg/L | Grab | Once per 2 Years ^{[1] [3]} |
| Cadmium, Total Recoverable | µg/L | Grab | Once per 2 Years ^{[1] [3]} |
| Chromium (VI), Total Recoverable | µg/L | Grab | Once per 2 Years ^{[1] [3]} |
| Copper, Total Recoverable | µg/L | Grab | Once per 2 Years ^{[1] [3]} |
| Lead, Total Recoverable | µg/L | Grab | Once per 2 Years ^{[1] [3]} |
| Mercury, Total Recoverable | µg/L | Grab | Once per 2 Years ^{[1] [3]} |
| Nickel, Total Recoverable | µg/L | Grab | Once per 2 Years ^{[1] [3]} |
| Selenium, Total Recoverable | µg/L | Grab | Once per 2 Years ^{[1] [3]} |
| Silver, Total Recoverable | µg/L | Grab | Once per 2 Years ^{[1] [3]} |
| Zinc, Total Recoverable | µg/L | Grab | Once per 2 Years ^{[1] [3]} |
| CTR Pollutants ^{[4] [5]} | µg/L | Grab | 1/Year |
| Title 22 Pollutants ^{[6] [7]} | µg/L | Grab | 1/Year |

^[1] Weekly and biennial samples shall be collected during the first day of a discharge event.

^[2] Whole effluent chronic toxicity monitoring shall be conducted according to the requirements established in section V.A of this MRP.

^[3] Samples shall be collected from Discharge Point No. 002 during the first discharge event following adoption of the Order and then at 2-year intervals thereafter.

^[4] Those 126 pollutants with applicable water quality objectives established by the California Toxics Rule (CTR) at 40 CFR 131.38.

^[5] Analyses, compliance determination, and reporting for these pollutants shall adhere to applicable provisions of the Policy for Implementation of Toxics Standards for Inland Surface Waters, Enclosed Bays, and Estuaries of California (SIP). The Discharger shall instruct its analytical laboratory to establish calibration standards so that the Minimum Levels (MLs) presented in Appendix 4 of the SIP are the lowest calibration standards. The Discharger and its analytical laboratory shall select MLs, which are below applicable water quality criteria of the CTR; and when applicable water quality criteria are below all MLs, the Discharger and its analytical laboratory shall select the lowest ML.

^[6] Analytical methods shall adhere to the Detection Limits for Purposes of Reporting (DLRs) established by Title 22 of the California Code of Regulations, Division 4, Chapter 15, section 64432 (inorganics) and section 64445.1 (organics).

^[7] The Title 22 pollutants are those pollutants for which the Department of Public Health has established Maximum Contaminant Levels (MCLs) at Title 22, Division 4, Chapter 15, sections 64431 (inorganic chemicals) and 64444 (organic chemicals) of the California Code of Regulations.

V. WHOLE EFFLUENT TOXICITY TESTING REQUIREMENTS

A. Chronic Toxicity Testing

The Permittee shall conduct chronic toxicity testing in accordance with the following chronic toxicity testing requirements.

1. **Test Frequency.** The Permittee shall conduct chronic toxicity testing in accordance with the schedule established by this MRP while discharging at Discharge Point No. 002, as summarized in Table E-2, above.
2. **Discharge In-stream Waste Concentration (IWC) for Chronic Toxicity.** The chronic toxicity IWC for this discharge is 100 percent effluent.
3. **Sample Volume and Holding Time.** The total sample volume shall be determined by the specific toxicity test method used. Sufficient sample volume shall be collected to perform the required toxicity test. All toxicity tests shall be conducted as soon as possible following sample collection. No more than 36 hours shall elapse before the conclusion of sample collection and test initiation.
4. **Freshwater Test Species and Test Methods.** The Permittee shall conduct the following chronic toxicity tests on effluent samples at the IWC for the discharge in accordance with species and test methods in *Short-Term Methods for Estimating the Chronic Toxicity of Effluents and Receiving Water to Freshwater Organisms* (U.S. EPA Report No. EPA-821-R-02-013, or subsequent editions). In no case shall these species be substituted with another test species unless written authorization from the Executive Officer is received.
 - a. A 96-hour static renewal or static non-renewal toxicity test with a vertebrate, the fathead minnow, *Pimephales promelas* (Larval Survival and Growth Test Method 1000.0).
 - b. A 96-hour static renewal or static non-renewal toxicity test with an invertebrate, the water flea, *Ceriodaphnia dubia* (Survival and Reproduction Test Method 1002.01).
 - c. A 96-hour static renewal or static non-renewal toxicity test with a plant, the green algae, *Selenastrum capricornutum* (also named *Raphidocelis subcapitata*) (Growth Test Method 1003.0).
5. **Species Sensitivity Screening.** Species sensitivity screening shall be conducted during this permit's first required sample collection. The Permittee shall collect a single effluent sample and concurrently conduct three toxicity tests using the fish, the invertebrate, and the alga species identified in section V.A.4, above. This sample shall also be analyzed for the parameters required for the discharge. The species that exhibits the highest "Percent (%) Effect" at the discharge IWC during species sensitivity screening shall be used for routine monitoring during the permit term.
6. **Quality Assurance and Additional Requirements.** Quality assurance measures, instructions, and other recommendations and requirements are found in the test methods manual previously referenced. Additional requirements are specified below.
 - a. The discharge is subject to determination of "Pass" or "Fail" and "Percent (%) Effect" from a single-effluent concentration chronic toxicity test at the discharge IWC using the TST approach described in *National Pollutant Discharge Elimination System Test of Significant Toxicity Implementation Document* (EPA 833-R10-003, 2010), Appendix A, Figure A-1, and Table A-1. The null hypothesis (Ho) for the TST approach is: Mean discharge IWC response $0.75 \times$ Mean control response. A test result that rejects this null hypothesis is reported as "Pass". A test result that does not reject this null hypothesis is reported as "Fail". The relative "Percent (%) Effect"

at the discharge IWC is defined and reported as: $((\text{Mean control response Mean discharge IWC response}) \div \text{Mean control response}) \times 100$.

- b. If the effluent toxicity test does not meet all TAC specified in the referenced test method, then the Permittee must re-sample and re-test within 14 days.
- c. Dilution water and control water shall be laboratory water prepared and used as specified in the test methods manual. For the *Selenastrum capricornutum* test, synthetic laboratory water with a hardness similar to the receiving water shall be used as the control and dilution water. If dilution water and control water is different from test organism culture water, then a second control using culture water shall also be used.
- d. Monthly reference toxicant testing shall be performed. All reference toxicant test results should be reviewed and reported.
- e. The Permittee shall perform toxicity tests on final effluent samples. Chlorine and ammonia shall not be removed from the effluent sample prior to toxicity testing, unless explicitly authorized under this section of the MRP and the rationale is explained in the Fact Sheet (Attachment F).
- f. **Ammonia Removal.** Except with prior approval from the Executive Officer of the Regional Water Board, ammonia shall not be removed from bioassay samples. The Permittee must demonstrate the effluent toxicity is caused by ammonia because of increasing test pH when conducting the toxicity test. It is important to distinguish the potential toxic effects of ammonia from other pH sensitive chemicals, such as certain heavy metals, sulfide, and cyanide. The following conditions and steps may be used to demonstrate that the toxicity is caused by ammonia and not other toxicants before the Executive Officer would allow for control of pH in the test.
 - i. There is consistent toxicity in the effluent and the maximum pH in the toxicity test is in the range to cause toxicity due to increased pH.
 - ii. Chronic ammonia concentrations in the effluent are greater than 4 mg/L total ammonia.
 - iii. Conduct graduated pH tests as specified in the toxicity identification evaluation (TIE) methods. For example, mortality should be higher at pH 8 and lower at pH 6.
 - iv. Treat the effluent with a zeolite column to remove ammonia. Mortality in the zeolite treated effluent should be lower than the non-zeolite treated effluent. Then add ammonia back to the zeolite-treated samples to confirm toxicity due to ammonia.

When it has been demonstrated that toxicity is due to ammonia because of increasing test pH, pH may be controlled using appropriate procedures which do not significantly alter the nature of the effluent.

- 7. **Notification.** The Permittee shall notify the Regional Water Board verbally within 72 hours and in writing within 14 days after the receipt of test results exceeding a median monthly summary result of "Fail" during routine monitoring or a single test result of "Fail" during accelerated monitoring.
- 8. **Accelerated Monitoring Requirements.** Within 24 hours of the time the Permittee becomes aware of a median monthly summary result "Fail", the Permittee shall

implement an accelerated monitoring schedule consisting of four toxicity tests—consisting of 5-effluent concentrations (including the discharge IWC) and a control—conducted at approximately 2 week intervals, over an 8 week period. If each of the accelerated toxicity tests results is “Pass,” the Permittee shall return to routine monitoring for the next monitoring period. If one of the accelerated toxicity tests results in “Fail”, the Permittee shall immediately implement the Toxicity Reduction Evaluation (TRE) Process conditions set forth below.

9. Toxicity Reduction Evaluation (TRE) Process

- a. Preparation and Implementation of a Detailed TRE Work Plan.** The Permittee shall immediately initiate a TRE using, according to type of treatment facility, EPA manual *Generalized Methodology for Conducting Industrial Toxicity Reduction Evaluations* (EPA/600/2-88/070, 1989) and within 30 days submit to the Regional Water Board Executive Officer a detailed TRE Work Plan, which shall follow the generic initial investigation TRE Work Plan revised as appropriate for this toxicity event. It shall include the following information, and comply with additional conditions set by the Regional Water Board Executive Officer:

 - i. Further actions by the Permittee to investigate, identify, and correct causes of toxicity.
 - ii. Actions the Permittee will take to mitigate effects of the discharge and prevent the recurrence of toxicity.
 - iii. A schedule for these actions, progress reports, and the final report.
- b. TIE Implementation.** The Permittee may initiate a TIE as part of a TRE to identify the causes of toxicity using the same species and test methods and, as guidance, EPA manuals: *Methods for Aquatic Toxicity Identification Evaluations: Phase I Toxicity Characterization Procedures* (EPA/600/6-91/003, 1991); *Methods for Aquatic Toxicity Identification Evaluations, Phase II Toxicity Identification Procedures for Samples Exhibiting Acute and Chronic Toxicity* (EPA/600/R-92/080, 1993); *Methods for Aquatic Toxicity Identification Evaluations, Phase III Toxicity Confirmation Procedures for Samples Exhibiting Acute and Chronic Toxicity* (EPA/600/R-92/081, 1993); and *Marine Toxicity Identification Evaluation (TIE): Phase I Guidance Document* (EPA/600/R-96-054, 1996). The TIE should be conducted on the species demonstrating the most sensitive toxicity response.
- c.** Many recommended TRE elements parallel required or recommended efforts for source control, pollution prevention, and storm water control programs. TRE efforts should be coordinated with such efforts. As toxic substances are identified or characterized, the Permittee shall continue the TRE by determining the sources and evaluating alternative strategies for reducing or eliminating the substances from the discharge. All reasonable steps shall be taken to reduce toxicity to levels consistent with toxicity evaluation parameters.
- d.** The Permittee shall conduct routine effluent monitoring for the duration of the TRE process. Additional accelerated monitoring and TRE work plans are not required once a TRE has begun.
- e.** The Regional Water Board recognizes that toxicity may be episodic and identification of the causes and reduction of sources of toxicity may not be successful in all cases. The TRE may be ended at any stage if monitoring finds there is no longer toxicity.

- 10. Reporting.** The SMR shall include a full laboratory report for each toxicity test. This report shall be prepared using the format and content of the test methods manual chapter called Report Preparation, including:
- The toxicity test results for the TST approach, reported as “Pass” or “Fail” and “Percent (%) Effect” at the chronic toxicity IWC for the discharge.
 - Water quality measurements for each toxicity test (e.g., pH, dissolved oxygen, temperature, conductivity, hardness, salinity, chlorine, ammonia).
 - TRE/TIE results. The Executive Officer shall be notified no later than 30 days from completion of each aspect of TRE/TIE analyses.
 - Statistical program (e.g., TST calculator, CETIS, etc.) output results for each toxicity test.

VI. LAND DISCHARGE MONITORING REQUIREMENTS – NOT APPLICABLE

VII. RECLAMATION MONITORING REQUIREMENTS – NOT APPLICABLE

VIII. RECEIVING WATER MONITORING REQUIREMENTS – SURFACE WATER

A. Monitoring Locations RSW-001 and RSW-002

- The Discharger shall monitor the Soquel Creek at RSW-001 and RSW-002 as follows:

Table E-3. Receiving Water Monitoring Requirements

| Parameter | Units | Sample Type | Minimum Sampling Frequency |
|----------------------------------|-------|-------------------|----------------------------|
| Dissolved Oxygen | mg/L | Field Measurement | 1/Month ^[1] |
| Visual Observations | --- | Field Observation | 1/Month ^[1] |
| Turbidity | NTU | Grab | 1/Month ^[1] |
| TSS | mg/L | Grab | 1/Month ^[1] |
| Settleable Solids | mL/L | Grab | 1/Month ^[1] |
| Hardness (as CaCO ₃) | mg/L | Grab | 1/Year ^[2] |
| Metals ^[3] | µg/L | Grab | 1/Permit Term |

^[1] This monitoring schedule assumes that storm water discharges will occur only during the California rainy season. Monthly and annual samples, therefore, shall be collected only during the rainy season (October through April). The Discharger shall make reasonable efforts to collect monthly receiving water samples during periods of discharge of process water and/or storm water from the Facility.

^[2] Hardness shall be monitored at RSW-002 only.

^[3] Metals are those with numeric effluent limitations (aluminum, arsenic, barium, cadmium, chromium, copper, lead, mercury, nickel, selenium, silver, and zinc). Metals shall be monitored at Monitoring Location RSW-001, only one time during the term of this Order. Metals concentrations in receiving water will be used to compare background conditions with metals concentrations in discharges from Discharge Point No. 002. Because this monitoring schedule assumes that discharges from Discharge Point No. 002 will occur only during the California rainy season, receiving water samples for metals analysis shall be collected between October and April.

IX. BIOSOLIDS MONITORING – NOT APPLICABLE

X. OTHER MONITORING REQUIREMENTS – NOT APPLICABLE

XI. REPORTING REQUIREMENTS

A. General Monitoring and Reporting Requirements

The Discharger shall comply with all Federal Standard Provisions and Central Coast Water Board Standard Provisions (Attachment D) related to monitoring, reporting, and recordkeeping.

B. Self-Monitoring Reports (SMRs)

1. The Discharger shall electronically submit SMR's using the State Water Board's California Integrated Water Quality System (CIWQS) Program Web site (<http://www.waterboards.ca.gov/ciwqs/index.html>). The CIWQS website will provide additional information for SMR submittal in the event there will be a planned service interruption for electronic submittal. The Discharger shall use the current version of the Permittee Entry Template (PET) tool to configure data into the applicable CIWQS Data Format, and shall update that template according to this Order (e.g., add/delete parameters, revise limits, update monitoring locations, etc.). Blank versions of the latest PET tool are available at

http://www.waterboards.ca.gov/water_issues/program/ciwqs/chc_npdes.shtml.

2. The Discharger shall report in the SMR the results for all monitoring specified in this MRP under sections III through IX. The Discharger shall submit SMR's including the results of all required monitoring using U.S. EPA-approved test methods or other test methods specified in this Order. If the Discharger monitors any pollutant more frequently than required by this Order, the results of this monitoring shall be included in the calculations and reporting of the data submitted in the SMR.
3. Sampling and monitoring as required by this MRP shall begin on the effective date of this Order. The Discharger shall complete all required monitoring and reporting according to the following schedule unless otherwise directed by the Executive Officer:

Table E-4. Monitoring Periods and Reporting Schedule

| SMR Name | Permit Section for Monitoring & Sampling Data Included in this Report | SMR Submittal Frequencies | SMR Due Date |
|---|--|----------------------------------|--|
| NPDES Monitoring Report – Monthly | MRP Sections IV (Effluent) and VIII (Receiving Water) | Monthly | First day of second calendar month following period of sampling (first report due Dec 1, 2017) |
| NPDES Monitoring Report – Biennial | MRP Section IV (Effluent) – metals and chronic toxicity | Biennial | May 1, 2018, 2020, 2022 (following storm season sampling from prior year), |
| NPDES Monitoring Report – Annual | MRP Section IV (Effluent) – CTR and Title 22 and Section VIII (Receiving Water) - hardness | Annually | May 1 annually following storm season sampling of prior year |
| NPDES Monitoring Report – once per permit | MRP Section VIII (Receiving Water) - metals | Once per permit | April 1, 2022 |
| NPDES Summary Report | Attachment D, Standard Provision VIII.D.8 | Annually | January 30 following calendar year of sampling |

| SMR Name | Permit Section for Monitoring & Sampling Data Included in this Report | SMR Submittal Frequencies | SMR Due Date |
|--|---|---------------------------|---|
| Erosion Control Inspection Certification | Special Provision VI.C.4.a of the Order | Annually | October 1 st annually beginning 2017 |

- 4. Reporting Protocols.** The Discharger shall report with each sample result the applicable reported Minimum Level (reported ML, also known as the Reporting Level, or RL) and the current Method Detection Limit (MDL), as determined by the procedure in 40 C.F.R. part 136.

The Discharger shall report the results of analytical determinations for the presence of chemical constituents in a sample using the following reporting protocols:

- a. Sample results greater than or equal to the reported ML shall be reported as measured by the laboratory (i.e., the measured chemical concentration in the sample).
- b. Sample results less than the reported ML, but greater than or equal to the laboratory’s MDL, shall be reported as “Detected, but Not Quantified,” or DNQ. The estimated chemical concentration of the sample shall also be reported.

For the purposes of data collection, the laboratory shall write the estimated chemical concentration next to DNQ as well as the words “Estimated Concentration” (may be shorted to “Est. Conc.”). The laboratory may, if such information is available, include numerical estimates of the data quality for the reported result. Numerical estimates of data quality may be percent accuracy (\pm a percentage of the reported value), numerical ranges (low to high), or any other means considered appropriate by the laboratory.

- c. Sample results less than the laboratory’s MDL shall be reported as “Not Detected,” or ND.
 - d. Dischargers are to instruct laboratories to establish calibration standards so that the ML value (or its equivalent if there is differential treatment of samples relative to calibration standards) is the lowest calibration standard. At no time is the Discharger to use analytical data derived from extrapolation beyond the lowest point of the calibration curve.
- 5. Compliance Determination.** Compliance with effluent limitations for priority pollutants shall be determined using sample reporting protocols defined above and Attachment A of this Order. For purposes of reporting and administrative enforcement by the Regional and State Water Board, the Discharger shall be deemed out of compliance with effluent limitations if the concentration of the priority pollutant in the in the monitoring sample is greater than the effluent limitation and greater than or equal to the reported Minimum Level (ML).
- 6. Multiple Sample Data.** When determining compliance with an average monthly effluent limitation (AMEL), average weekly effluent limitation (AWEL), or maximum daily effluent limitation, the Discharger shall compute the arithmetic mean unless the data set contains one or more reported determinations of “Detected, but Not Quantified” (DNQ) or “Not

Detected” (ND). In those cases, the Discharger shall compute the median in place of the arithmetic mean in accordance with the following procedure:

- a. The data set shall be ranked from low to high, ranking the reported ND determinations lowest, DNQ determinations next, followed by quantified values (if any). The order of the individual ND or DNQ determinations is unimportant.
 - b. The median value of the data set shall be determined. If the data set has an odd number of data points, then the median is the middle value. If the data set has an even number of data points, then the median is the average of the two values around the middle unless one or both of the points are ND or DNQ, in which case the median value shall be the lower of the two data points where DNQ is lower than a value and ND is lower than DNQ.
7. The Discharger shall submit SMR’s in accordance with the following requirements:
- a. The Discharger shall arrange all reported data in a tabular format. The data shall be summarized to clearly illustrate whether the facility is operating in compliance with interim and/or final effluent limitations. The Discharger is not required to duplicate the submittal of data that is entered in a tabular format within CIWQS. When electronic submittal of data is required and CIWQS does not provide for entry into a tabular format within the system, the Discharger shall electronically submit the data in a tabular format as an attachment.
 - b. The Discharger shall include in their CIWQS upload a cover letter to the SMR. The information contained in the cover letter shall clearly identify violations of the WDRs; discuss corrective actions taken or planned; and the proposed time schedule for corrective actions. Identified violations must include a description of the requirement that was violated and a description of the violation. Uploaded reports must also include laboratory data sheets for the analytical results being presented.
 - c. SMRs must be submitted to the Regional Water Board, signed and certified as required by the Standard Provisions (Attachment D), to the address listed below:

California Regional Water Quality Control Board
Central Coast Region
895 Aerovista Place, Suite 101
San Luis Obispo, CA 93401

C. Discharge Monitoring Reports (DMR’s)

- 1. As of the effective date of this Order, if the Discharger operates a “minor” facility as designated on page 1 of this Order, submittal of Discharge Monitoring Reports (DMRs) is not required. However, at any time during the term of this Order, the State Water Board or Central Coast Water Board may notify and require the Discharger to electronically submit DMRs.
- 2. DMR’s must be signed and certified as required by the standard provisions (Attachment D). The Discharger shall submit the original DMR and one copy of the DMR to one of the addresses listed below:

| | |
|----------------------|--|
| STANDARD MAIL | FEDEX/UPS/ OTHER PRIVATE CARRIERS |
|----------------------|--|

| | |
|--|--|
| State Water Resources Control Board Division of Water Quality c/o DMR Processing Center PO Box 100 Sacramento, CA 95812-1000 | State Water Resources Control Board Division of Water Quality c/o DMR Processing Center 1001 I Street, 15 th Floor Sacramento, CA 95814 |
|--|--|

3. All discharge monitoring results must be reported on the official U.S. EPA pre-printed DMR forms (EPA Form 3320-1). Forms that are self-generated will not be accepted unless they follow the exact same format of EPA Form 3320-1.

D. Other Reports

1. In accordance with Special Provision VI.C.4.a of the Order, the Discharger shall certify by October 1 of each year that necessary measures have been taken and pollution control equipment and systems are in proper condition to comply with the terms of the Order during the impending rainy season.
2. The Discharger shall report the results of any special monitoring, TREs, or other data or information that results from the Special Provisions, section VI.C, of the Order. The Discharger shall submit such reports with the first quarterly SMR scheduled to be submitted on or immediately following the report due date.

ATTACHMENT F – FACT SHEET

Contents

| | | |
|------|--|------|
| I. | Permit Information | F-3 |
| II. | Facility Description..... | F-4 |
| | A. Description of Process Wastewater and Facility Operations | F-4 |
| | B. Discharge Points and Receiving Waters | F-5 |
| | C. Summary of Existing Requirements and Self-Monitoring Report (SMR) Data..... | F-5 |
| | D. Compliance Summary..... | F-8 |
| | E. Planned Changes..... | F-8 |
| III. | Applicable Plans, Policies, and Regulations | F-8 |
| | A. Legal Authorities | F-8 |
| | B. California Environmental Quality Act (CEQA)..... | F-9 |
| | C. State and Federal Laws, Regulations, Policies, and Plans..... | F-9 |
| | D. Impaired Water Bodies on CWA 303(d) List..... | F-10 |
| | E. Other Plans, Policies and Regulations..... | F-11 |
| IV. | Rationale for Effluent Limitations and Discharge Specifications..... | F-11 |
| | A. Discharge Prohibitions | F-11 |
| | B. Technology-Based Effluent Limitations..... | F-12 |
| | 1. Scope and Authority..... | F-12 |
| | 2. Applicable Technology-Based Effluent Limitations..... | F-12 |
| | C. Water Quality-Based Effluent Limitations..... | F-13 |
| | 1. Scope and Authority..... | F-13 |
| | 2. Applicable Beneficial Uses and Water Quality Criteria and Objectives..... | F-14 |
| | 3. Determining the Need for WQBELs..... | F-14 |
| | 4. WQBEL Calculations..... | F-15 |
| | 5. Whole Effluent Toxicity (WET)..... | F-15 |
| | 6. pH..... | F-18 |
| | D. Final Effluent Limitation Considerations | F-18 |
| | 1. Anti-Backsliding Requirements..... | F-18 |
| | 2. Antidegradation Policies..... | F-18 |
| | 3. Stringency of Requirements for Individual Pollutants..... | F-18 |
| | 4. Summary of Final Effluent Limitations – Discharge Point No. 002..... | F-18 |
| | E. Reclamation Specifications – Not Applicable..... | F-21 |
| V. | Rationale for Receiving Water Limitations | F-21 |
| | A. Surface Water..... | F-21 |
| | B. Groundwater – Not Applicable..... | F-21 |
| VI. | Rationale for Monitoring and Reporting Requirements..... | F-21 |
| | A. Influent Monitoring – Not Applicable..... | F-21 |
| | B. Effluent Monitoring..... | F-21 |
| | C. Whole Effluent Toxicity Testing Requirements | F-21 |
| | D. Reclaimed Water Monitoring – Not Applicable..... | F-22 |
| | E. Receiving Water Monitoring..... | F-22 |
| | F. Land Discharge Monitoring Requirements – Not Applicable | F-22 |
| | G. Other Monitoring Requirements – Not Applicable..... | F-22 |
| VII. | Rationale for Provisions..... | F-22 |
| | A. Standard Provisions..... | F-22 |
| | B. Special Provisions..... | F-22 |
| | 1. Reopener Provisions..... | F-22 |

- 2. Special Studies and Additional Monitoring Requirements..... F-22
- 3. Best Management Practices and Pollution Prevention – Not Applicable F-23
- 4. Construction, Operation, and Maintenance Specifications..... F-23
- 5. Special Provisions for Municipal Facilities (POTWs Only) – Not Applicable F-23
- 6. Other Special Provisions..... F-23
- 7. Compliance Schedules – Not Applicable F-23
- VIII. Public Participation F-23
 - A. Notification of Interested Parties F-23
 - B. Written Comments F-24
 - C. Public Hearing..... F-24
 - D. Reconsideration of Waste Discharge Requirements..... F-24
 - E. Information and Copying F-24
 - F. Register of Interested Persons F-25
 - G. Additional Information..... F-25

Tables

- Table F-1. Facility Information..... F-3
- Table F-2. Historic Effluent Limitations and Monitoring Data..... F-5
- Table F-3. Basin Plan Beneficial Uses..... F-9
- Table F-4. Effluent Limitations Guidelines..... F-13
- Table F-5. Additional Technology-Based Effluent Limitations Retained from Previous Order..... F-13
- Table F-6. Final Effluent Limitations..... F-18

ATTACHMENT F – FACT SHEET

This Fact Sheet includes the legal requirements and technical rationale that serve as the basis for the requirements of this Order. As described in section II.B, the Central Coast Water Board incorporates this Fact Sheet as findings of the Central Coast Water Board supporting the issuance of this Order.

I. PERMIT INFORMATION

The following table summarizes administrative information related to the facility.

Table F-1. Facility Information

| | |
|---|---|
| WDID | 3 442009001 |
| Discharger | Olive Springs Quarry, Inc. |
| Name of Facility | Olive Springs Quarry, Inc. |
| Facility Address | 1299 Olive Springs Road |
| | Soquel, CA 95073 |
| | Santa Cruz |
| Facility Contact, Title and Phone | Christine Bone, President, (831) 475-1610 |
| Authorized Person to Sign and Submit Reports | Same as above |
| Mailing Address | P.O. Box 747, Soquel, CA 95073 |
| Billing Address | Same as mailing address |
| Type of Facility | NAICS Code 212313 – Crushed and Broken Granite Mining and Quarrying |
| Major or Minor Facility | Minor |
| Threat to Water Quality | 3 |
| Complexity | A |
| Pretreatment Program | None |
| Recycling Requirements | None |
| Facility Permitted Flow | None |
| Facility Design Flow | Design Flow Not Applicable. No discharges occurred during the previous permit term at Discharge Point No. 002. The last reported discharge occurred from 2000-2002, where discharges of process wastewater occurred 3 to 4 days per year at approximately 0.03 million gallons per day (MGD). |
| Watershed | Soquel Creek Watershed |
| Receiving Water | Soquel Creek |
| Receiving Water Type | Inland Freshwater |

- A.** The CHY Company and Olive Springs Quarry, Inc. (hereinafter Discharger) is the operator of Olive Springs Quarry (hereinafter Facility), a granite quarry and processing facility. The CHY Company, the forestland division of Setzer Forest Products, Inc., owns the property at 1299 Olive Springs Road on which the Facility is located.

For the purposes of this Order, references to the “discharger” or “permittee” in applicable federal and state laws, regulations, plans, or policy are held to be equivalent to references to the Discharger herein.

- B. The Discharger is regulated pursuant to National Pollutant Discharge Elimination System (NPDES) Permit No. CA0047791. It was previously regulated by Order No. R3-2010-0039 which was adopted on December 9, 2010 and expired on December 9, 2015. The terms and conditions of the current Order have been automatically continued and remain in effect until new Waste Discharge Requirements (WDRs) and National Pollutant Discharge Elimination System (NPDES) permit are adopted pursuant to this Order. Attachment B provides a map of the area around the Facility. Attachment C provides a flow schematic of the Facility.

The Discharger must file a petition with the State Water Resources Control Board (State Water Board), Division of Water Rights, and receive approval for any change in the point of discharge, place of use, or purpose of use of treated wastewater that decreases the flow in any portion of a watercourse. The State Water Board retains the jurisdictional authority to enforce such requirements under Water Code section 1211.

- C. The Discharger filed a report of waste discharge and submitted an application for reissuance of its WDR's and NPDES permit on August 14, 2015.

II. FACILITY DESCRIPTION

A. Description of Process Wastewater and Facility Operations

The Facility is a granite quarry and processing facility, which consists of three parcels of land (Leasehold 1, 2, and 3) leased from the CHY Company, the forestland division of Setzer Forest Products, Inc. Leasehold 1 is on the Facility's western side and includes the granite quarry and processing areas (rock sorter, rock washer, asphalt batch plant, truckbed wash rack, and associated structures and processes). The Discharger uses no explosives. The Discharger has disturbed no land and conducts no industrial activity on Leasehold 2, which is between Leasehold 1 and 3. Leasehold 3, comprising approximately 15 acres, is in the Facility's southwestern portion and includes the office, weigh station, and a large field used for stockpiling fill material.

Wash plant and asphalt plant process wastewater and storm water from the processing area, flow to a settling pond, from which clarified water is recycled. The Discharger uses a polymer to enhance separation and enable recycling of process water. Solids are dredged from the settling pond approximately every other month and are used offsite by providers of "bagged" soil.

Provisions of Industrial Activities Storm Water General Permit No. 2014-0057-DWQ (NPDES General Permit CAS000001) regulate storm water discharges from Discharge Point Nos. 001, 003, 004, and 005. Storm water from the quarry area, and a 2 gallons per minute (gpm) groundwater seep from the quarry's exposed wall, flow to Pond A (with approximately 211,000 cubic feet of capacity), the first of three storm water detention ponds on the Leasehold 1 area. Pond A overflows into Pond B (with approximately 240,000 cubic feet of capacity) through an elevation control pipe; and overflow from Pond B enters Pond C, where it is recycled to the quarry's processing area. During storm events, Pond B can discharge directly to Soquel Creek at Discharge Point No. 001. Discharges from Pond B occur through a siphon so discharges continue until the surface elevation of Pond B falls to 10 to 15 feet below the elevation of the outlet pipe.

Pond C, with a design capacity of 110,000 cubic feet, receives overflow/clarified water from Pond B and from the settling pond that serves the quarry's processing area. Water is either recycled from Pond C, or, during significant storm events, it overflows to Soquel Creek through Discharge Point No. 002. When makeup water is needed for processing, it is pumped

from Soquel Creek into Pond C. Due to extensive recycling of process water, no discharges occurred from Discharge Point No. 002 during the term of the current Order. The last known discharges occurred between 2000 and 2002, when discharges of process wastewater occurred 3 to 4 days per year at approximately 0.03 MGD.

The Discharger constructed three detention ponds in Leasehold 3 to collect and clarify storm water from unpaved areas used to stockpile fill and other unprocessed material. Two ponds discharge (Discharge Points Nos. 003 and 004) to a drainage ditch that follows Olive Springs Road and flows to Soquel Creek. The third pond (Discharge Point No. 005) discharges to a 24-inch culvert that flows directly to Soquel Creek. The ponds have 2 to 3-foot berms constructed of ¾ inch washed granite, which retain storm water to allow settling and filtration before discharge.

The Discharger periodically removes the berms and returns them to the processing area to remove filtered and settled solids. Up gradient to the Leasehold 3 area is a 44-acre residential development, which is surrounded by drainage ditches. During significant storm events, these drainage ditches can overflow onto Leasehold 3. Stockpiles on the Leasehold 3 area are maintained with vegetative cover.

On-site storm water collection and control facilities are designed to retain runoff from a 50-year, 2-hour storm event, in accordance with applicable mining regulations of the Santa Cruz County Code at Chapter 16.54.

B. Discharge Points and Receiving Waters

Discharges of combined process wastewater and storm water from Pond C to Soquel Creek occur at Discharge Point No. 002 (37° 03' 30" N Latitude; 121° 55' 15" W Longitude). Soquel Creek flows through the Big Basin Hydrologic Unit and ultimately discharges to the Pacific Ocean.

C. Summary of Existing Requirements and Self-Monitoring Report (SMR) Data

Effluent limitations contained in the existing Order for discharges from Discharge Point No. 002 (Monitoring Location EFF-002) and representative monitoring data from the term of the previous Order are as follows:

Table F-2. Historic Effluent Limitations and Monitoring Data

| Parameter | Units | Effluent Limitation | | Monitoring Data (From December 2010 – August 2015) | |
|------------------------------|----------------|------------------------|------------------|--|--|
| | | Average Monthly | Maximum Daily | Highest Average Monthly Discharge | Highest Instant Max Discharge |
| pH | standard units | 7.0 – 8.3 at all times | | ND ^[1] | |
| Total Suspended Solids (TSS) | mg/L | --- | 50 | ND ^[1] | ND ^[1] |
| Settleable Solids | ml/L | 0.3 | --- | ND ^[1] | ND ^[1] |
| Acute Toxicity | TUa | --- | 1 | ND ^[1] | ND ^[1] |
| Mercury, Total Recoverable | µg/L | 0.050 | 0.10 | ND ^[1] | ND ^[1] |
| Selenium, Total Recoverable | µg/L | 10 | 20 | ND ^[1] | ND ^[1] |
| Cyanide, Total Recoverable | µg/L | 4.3 | 8.5 | ND ^[1] | ND ^[1] |

| Parameter | Units | Effluent Limitation | | Monitoring Data (From December 2010 – August 2015) | |
|-----------------------------------|----------|---------------------|---------------|--|-------------------------------|
| | | Average Monthly | Maximum Daily | Highest Average Monthly Discharge | Highest Instant Max Discharge |
| Antimony, Total Recoverable | µg/L | 6.0 | 12 | ND ⁽¹⁾ | ND ⁽¹⁾ |
| Arsenic, Total Recoverable | µg/L | 50 | 100 | ND ⁽¹⁾ | ND ⁽¹⁾ |
| Beryllium, Total Recoverable | µg/L | 4.0 | 8.0 | ND ⁽¹⁾ | ND ⁽¹⁾ |
| Cadmium, Total Recoverable | µg/L | 5.0 | 10 | ND ⁽¹⁾ | ND ⁽¹⁾ |
| Chromium (III), Total Recoverable | µg/L | 468 | 940 | ND ⁽¹⁾ | ND ⁽¹⁾ |
| Chromium (IV), Total Recoverable | µg/L | 8.1 | 16 | ND ⁽¹⁾ | ND ⁽¹⁾ |
| Copper, Total Recoverable | µg/L | 22 | 44 | ND ⁽¹⁾ | ND ⁽¹⁾ |
| Lead, Total Recoverable | µg/L | 13 | 25 | ND ⁽¹⁾ | ND ⁽¹⁾ |
| Nickel, Total Recoverable | µg/L | 100 | 201 | ND ⁽¹⁾ | ND ⁽¹⁾ |
| Silver, Total Recoverable | µg/L | 17 | 34 | ND ⁽¹⁾ | ND ⁽¹⁾ |
| Thallium, Total Recoverable | µg/L | 1.7 | 3.4 | ND ⁽¹⁾ | ND ⁽¹⁾ |
| Zinc, Total Recoverable | µg/L | 164 | 329 | ND ⁽¹⁾ | ND ⁽¹⁾ |
| Asbestos | fibers/L | 7,000,000 | 14,000,000 | ND ⁽¹⁾ | ND ⁽¹⁾ |
| 2,3,7,8 TCDD | µg/L | 0.000000013 | 0.000000026 | ND ⁽¹⁾ | ND ⁽¹⁾ |
| Acrolein | µg/L | 320 | 642 | ND ⁽¹⁾ | ND ⁽¹⁾ |
| Acrylonitrile | µg/L | 0.059 | 0.12 | ND ⁽¹⁾ | ND ⁽¹⁾ |
| Benzene | µg/L | 1.0 | 2.0 | ND ⁽¹⁾ | ND ⁽¹⁾ |
| Bromoform | µg/L | 4.3 | 8.6 | ND ⁽¹⁾ | ND ⁽¹⁾ |
| Carbon Tetrachloride | µg/L | 0.25 | 0.50 | ND ⁽¹⁾ | ND ⁽¹⁾ |
| Chlorobenzene | µg/L | 30 | 60 | ND ⁽¹⁾ | ND ⁽¹⁾ |
| Chlorodibromomethane | µg/L | 0.40 | 0.80 | ND ⁽¹⁾ | ND ⁽¹⁾ |
| Chloroform | µg/L | 80 | 160 | ND ⁽¹⁾ | ND ⁽¹⁾ |
| Dichlorobromomethane | µg/L | 0.56 | 1.12 | ND ⁽¹⁾ | ND ⁽¹⁾ |
| 1,1-Dichloroethane | µg/L | 5.0 | 10 | ND ⁽¹⁾ | ND ⁽¹⁾ |
| 1,2-Dichloroethane | µg/L | 0.38 | 0.76 | ND ⁽¹⁾ | ND ⁽¹⁾ |
| 1,1-Dichloroethylene | µg/L | 0.057 | 0.11 | ND ⁽¹⁾ | ND ⁽¹⁾ |
| 1,2-Dichloropropane | µg/L | 0.52 | 1.0 | ND ⁽¹⁾ | ND ⁽¹⁾ |
| 1,3-Dichloropropylene | µg/L | 0.50 | 1.0 | ND ⁽¹⁾ | ND ⁽¹⁾ |
| Ethylbenzene | µg/L | 300 | 602 | ND ⁽¹⁾ | ND ⁽¹⁾ |
| Methyl Bromide | µg/L | 48 | 96 | ND ⁽¹⁾ | ND ⁽¹⁾ |
| Methylene Chloride | µg/L | 4.7 | 9.4 | ND ⁽¹⁾ | ND ⁽¹⁾ |
| 1,1,2,2-Tetrachloroethane | µg/L | 0.17 | 0.34 | ND ⁽¹⁾ | ND ⁽¹⁾ |
| Tetrachloroethylene | µg/L | 0.80 | 1.6 | ND ⁽¹⁾ | ND ⁽¹⁾ |
| Toluene | µg/L | 150 | 301 | ND ⁽¹⁾ | ND ⁽¹⁾ |
| 1,2-Trans-Dichloroethylene | µg/L | 10 | 20 | ND ⁽¹⁾ | ND ⁽¹⁾ |
| 1,1,1-Trichloroethane | µg/L | 200 | 401 | ND ⁽¹⁾ | ND ⁽¹⁾ |
| 1,1,2-Trichloroethane | µg/L | 0.60 | 1.2 | ND ⁽¹⁾ | ND ⁽¹⁾ |
| Trichloroethylene | µg/L | 2.7 | 5.4 | ND ⁽¹⁾ | ND ⁽¹⁾ |
| Vinyl Chloride | µg/L | 0.50 | 1.0 | ND ⁽¹⁾ | ND ⁽¹⁾ |
| 2-Chlorophenol | µg/L | 120 | 241 | ND ⁽¹⁾ | ND ⁽¹⁾ |
| 2,4-Dichlorophenol | µg/L | 93 | 187 | ND ⁽¹⁾ | ND ⁽¹⁾ |

| Parameter | Units | Effluent Limitation | | Monitoring Data (From December 2010 – August 2015) | |
|-----------------------------|-------|---------------------|---------------|--|-------------------------------|
| | | Average Monthly | Maximum Daily | Highest Average Monthly Discharge | Highest Instant Max Discharge |
| 2,4-Dimethylphenol | µg/L | 540 | 1,083 | ND ⁽¹⁾ | ND ⁽¹⁾ |
| 2-methyl-4,6-dinitrophenol | µg/L | 13 | 27 | ND ⁽¹⁾ | ND ⁽¹⁾ |
| 2,4-Dinitrophenol | µg/L | 70 | 140 | ND ⁽¹⁾ | ND ⁽¹⁾ |
| Pentachlorophenol | µg/L | 0.28 | 0.56 | ND ⁽¹⁾ | ND ⁽¹⁾ |
| Phenol | µg/L | 21,000 | 42,130 | ND ⁽¹⁾ | ND ⁽¹⁾ |
| 2,4,6-Trichlorophenol | µg/L | 2.1 | 4.2 | ND ⁽¹⁾ | ND ⁽¹⁾ |
| Acenaphthene | µg/L | 1,200 | 2,407 | ND ⁽¹⁾ | ND ⁽¹⁾ |
| Anthracene | µg/L | 9,600 | 19,259 | ND ⁽¹⁾ | ND ⁽¹⁾ |
| Benzidine | µg/L | 0.00012 | 0.00024 | ND ⁽¹⁾ | ND ⁽¹⁾ |
| Benzo(a)Anthracene | µg/L | 0.0044 | 0.0088 | ND ⁽¹⁾ | ND ⁽¹⁾ |
| Benzo(a)Pyrene | µg/L | 0.0044 | 0.0088 | ND ⁽¹⁾ | ND ⁽¹⁾ |
| Benzo(b)Fluoranthene | µg/L | 0.0044 | 0.0088 | ND ⁽¹⁾ | ND ⁽¹⁾ |
| Benzo(k)Fluoranthene | µg/L | 0.0044 | 0.0088 | ND ⁽¹⁾ | ND ⁽¹⁾ |
| Bis(2-Chloroethyl)Ether | µg/L | 0.031 | 0.062 | ND ⁽¹⁾ | ND ⁽¹⁾ |
| Bis(2-Chloroisopropyl)Ether | µg/L | 1,400 | 2,809 | ND ⁽¹⁾ | ND ⁽¹⁾ |
| Bis(2-Ethylhexyl)Phthalate | µg/L | 1.8 | 3.6 | ND ⁽¹⁾ | ND ⁽¹⁾ |
| Butylbenzyl Phthalate | µg/L | 3,000 | 6,019 | ND ⁽¹⁾ | ND ⁽¹⁾ |
| 2-Chloronaphthalene | µg/L | 1,700 | 3,411 | ND ⁽¹⁾ | ND ⁽¹⁾ |
| Chrysene | µg/L | 0.0044 | 0.0088 | ND ⁽¹⁾ | ND ⁽¹⁾ |
| Dibenzo(a,h)Anthracene | µg/L | 0.0044 | 0.0088 | ND ⁽¹⁾ | ND ⁽¹⁾ |
| 1,2-Dichlorobenzene | µg/L | 600 | 1,204 | ND ⁽¹⁾ | ND ⁽¹⁾ |
| 1,3-Dichlorobenzene | µg/L | 400 | 802 | ND ⁽¹⁾ | ND ⁽¹⁾ |
| 1,4-Dichlorobenzene | µg/L | 5.0 | 10 | ND ⁽¹⁾ | ND ⁽¹⁾ |
| 3,3-Dichlorobenzidine | µg/L | 0.040 | 0.1 | ND ⁽¹⁾ | ND ⁽¹⁾ |
| Diethyl Phthalate | µg/L | 23,000 | 46,142 | ND ⁽¹⁾ | ND ⁽¹⁾ |
| Dimethyl Phthalate | µg/L | 313,000 | 627,937 | ND ⁽¹⁾ | ND ⁽¹⁾ |
| Di-n-Butyl Phthalate | µg/L | 2,700 | 5,417 | ND ⁽¹⁾ | ND ⁽¹⁾ |
| 2,4-Dinitrotoluene | µg/L | 0.11 | 0.22 | ND ⁽¹⁾ | ND ⁽¹⁾ |
| 1,2-Diphenylhydrazine | µg/L | 0.040 | 0.080 | ND ⁽¹⁾ | ND ⁽¹⁾ |
| Fluoranthene | µg/L | 300 | 602 | ND ⁽¹⁾ | ND ⁽¹⁾ |
| Fluorene | µg/L | 1,300 | 2,608 | ND ⁽¹⁾ | ND ⁽¹⁾ |
| Hexachlorobenzene | µg/L | 0.00075 | 0.0015 | ND ⁽¹⁾ | ND ⁽¹⁾ |
| Hexachlorobutadiene | µg/L | 0.44 | 0.88 | ND ⁽¹⁾ | ND ⁽¹⁾ |
| Hexachlorocyclopentadiene | µg/L | 50 | 100 | ND ⁽¹⁾ | ND ⁽¹⁾ |
| Hexachloroethane | µg/L | 1.9 | 3.8 | ND ⁽¹⁾ | ND ⁽¹⁾ |
| Indeno(1,2,3-cd)Pyrene | µg/L | 0.0044 | 0.0088 | ND ⁽¹⁾ | ND ⁽¹⁾ |
| Isophorone | µg/L | 8.4 | 17 | ND ⁽¹⁾ | ND ⁽¹⁾ |
| Nitrobenzene | µg/L | 17 | 34 | ND ⁽¹⁾ | ND ⁽¹⁾ |
| N-Nitrosodimethylamine | µg/L | 0.00069 | 0.0014 | ND ⁽¹⁾ | ND ⁽¹⁾ |
| N-Nitrosodi-n-Propylamine | µg/L | 0.0050 | 0.010 | ND ⁽¹⁾ | ND ⁽¹⁾ |
| N-Nitrosodiphenylamine | µg/L | 5.0 | 10 | ND ⁽¹⁾ | ND ⁽¹⁾ |

| Parameter | Units | Effluent Limitation | | Monitoring Data (From December 2010 – August 2015) | |
|------------------------|-------|---------------------|---------------|--|-------------------------------|
| | | Average Monthly | Maximum Daily | Highest Average Monthly Discharge | Highest Instant Max Discharge |
| Pyrene | µg/L | 960 | 1,926 | ND ^[1] | ND ^[1] |
| 1,2,4-Trichlorobenzene | µg/L | 5.0 | 10 | ND ^[1] | ND ^[1] |
| Aldrin | µg/L | 0.00013 | 0.00026 | ND ^[1] | ND ^[1] |
| alpha-BHC | µg/L | 0.0039 | 0.0078 | ND ^[1] | ND ^[1] |
| beta-BHC | µg/L | 0.014 | 0.028 | ND ^[1] | ND ^[1] |
| gamma-BHC | µg/L | 0.019 | 0.038 | ND ^[1] | ND ^[1] |
| Chlordane | µg/L | 0.00057 | 0.0011 | ND ^[1] | ND ^[1] |
| 4,4'-DDT | µg/L | 0.00059 | 0.0012 | ND ^[1] | ND ^[1] |
| 4,4'-DDE | µg/L | 0.00059 | 0.0012 | ND ^[1] | ND ^[1] |
| 4,4'-DDD | µg/L | 0.00083 | 0.0017 | ND ^[1] | ND ^[1] |
| Dieldrin | µg/L | 0.00014 | 0.00028 | ND ^[1] | ND ^[1] |
| alpha-Endosulfan | µg/L | 0.046 | 0.092 | ND ^[1] | ND ^[1] |
| beta-Endosulfan | µg/L | 0.046 | 0.092 | ND ^[1] | ND ^[1] |
| Endosulfan Sulfate | µg/L | 110 | 221 | ND ^[1] | ND ^[1] |
| Endrin | µg/L | 0.029 | 0.059 | ND ^[1] | ND ^[1] |
| Endrin Aldehyde | µg/L | 0.76 | 1.5 | ND ^[1] | ND ^[1] |
| Heptachlor | µg/L | 0.00021 | 0.00042 | ND ^[1] | ND ^[1] |
| Heptachlor Epoxide | µg/L | 0.00010 | 0.00020 | ND ^[1] | ND ^[1] |
| PCBs sum | µg/L | 0.00017 | 0.00034 | ND ^[1] | ND ^[1] |
| Toxaphene | µg/L | 0.00016 | 0.00033 | ND ^[1] | ND ^[1] |

[1] ND – No discharge during the permit term; no effluent data available.

D. Compliance Summary

The Discharger did not report any effluent discharge or have any reported violations during the term of the previous order.

E. Planned Changes

The Facility does not plan to implement any changes during the upcoming permit term.

III. APPLICABLE PLANS, POLICIES, AND REGULATIONS

The requirements contained in this Order are based on the requirements and authorities described in this section.

A. Legal Authorities

This Order serves as waste discharge requirements (WDRs) pursuant to article 4, chapter 4, division 7 of the California Water Code (commencing with section 13260). This Order is also issued pursuant to section 402 of the federal Clean Water Act (CWA) and implementing regulations adopted by the U.S. EPA and chapter 5.5, division 7 of the Water Code (commencing with section 13370). It shall serve as an NPDES permit for point source discharges from this facility to surface waters.

B. California Environmental Quality Act (CEQA)

Under Water Code section 13389, this action to adopt an NPDES permit is exempt from the provisions of Chapter 3 of CEQA, (commencing with section 21100) of Division 13 of the Public Resources Code.

C. State and Federal Laws, Regulations, Policies, and Plans

- 1. Water Quality Control Plan.** The Regional Water Quality Control Board (Central Coast Water Board) adopted a *Water Quality Control Plan for the Central Coast Basin* (hereinafter Basin Plan), the most recent version released in June 2011, that designates beneficial uses, establishes water quality objectives, and contains implementation programs and policies to achieve those objectives for all waters addressed through the plan. Requirements in this Order implement the Basin Plan.

Beneficial uses established by the Basin Plan for Soquel Creek are presented below:

Table F-3. Basin Plan Beneficial Uses

| Discharge Point | Receiving Water Name | Beneficial Use(s) |
|-----------------|----------------------|---|
| 002 | Soquel Creek | Municipal and Domestic Supply (MUN) Agricultural Supply (AGR) Industrial Supply (IND) Ground Water Recharge (GWR) Water Contact (REC-1) Non-Contact Recreation (REC-2) Wildlife Habitat (WILD) Cold Freshwater Habitat (COLD) Migration of Aquatic Organisms (MIGR) Fish Spawning (SPWN) Preservation of Biological Habitats of Special Significance (BIOL) Freshwater Replenishment (FRSH) Commercial and Sport Fishing (COMM) |

- 2. Thermal Plan.** The State Water Resources Control Board (State Water Board) adopted a *Water Quality Control Plan for Control of Temperature in the Coastal and Interstate Water and Enclosed Bays and Estuaries of California* (Thermal Plan) on May 18, 1972, and amended this plan on September 18, 1975. The Thermal Plan contains temperature objectives for inland surface waters, which are applicable to the Discharger. The general objective for temperature from Section II.A.2.a. of the Basin Plan is more limiting, however, and is included as a receiving water limitation in the Order.
- 3. National Toxics Rule (NTR) and California Toxics Rule (CTR).** U.S. EPA adopted the NTR on December 22, 1992, and later amended it on May 4, 1995 and November 9, 1999. About forty criteria in the NTR applied in California. On May 18, 2000, U.S. EPA adopted the CTR. The CTR promulgated new toxics criteria for California and, in addition, incorporated the previously adopted NTR criteria that were applicable in the state. The CTR was amended on February 13, 2001. These rules contain federal water quality criteria for priority pollutants.
- 4. State Implementation Policy.** On March 2, 2000, the State Water Board adopted the Policy for Implementation of Toxics Standards for Inland Surface Waters, Enclosed Bays,

and Estuaries of California (hereinafter State Implementation Policy or SIP). The SIP became effective on April 28, 2000, with respect to the priority pollutant criteria U.S. EPA promulgated for California through the NTR and the priority pollutant objectives the Central Coast Water Board established in the Basin Plan. The SIP became effective on May 18, 2000, with respect to the priority pollutant criteria U.S. EPA promulgated through the CTR. The State Water Board adopted amendments to the SIP on February 24, 2005, that became effective on July 13, 2005. The SIP establishes implementation provisions for priority pollutant criteria and objectives and provisions for chronic toxicity control. Requirements of this Order implement the SIP.

5. **Alaska Rule.** On March 30, 2000, USEPA revised its regulation that specifies when new and revised state and tribal water quality standards (WQS) become effective for CWA purposes (40 CFR 131.21, 65 Fed. Reg. 24641 (April 27, 2000)). Under the revised regulation (also known as the Alaska rule), new and revised standards submitted to USEPA after May 30, 2000, must be approved by USEPA before being used for CWA purposes. The final rule also provides that standards already in effect and submitted to USEPA by May 30, 2000, may be used for CWA purposes, whether or not approved by USEPA.
6. **Antidegradation Policy.** Federal regulation 40 C.F.R. section 131.12 requires that the state water quality standards include an antidegradation policy consistent with the federal policy. The State Water Board established California's antidegradation policy in State Water Board Resolution 68-16. Resolution 68-16 is deemed to incorporate the federal antidegradation policy where the federal policy applies under federal law. Resolution 68-16 requires that existing water quality be maintained unless degradation is justified based on specific findings. The Central Coast Water Board's Basin Plan implements, and incorporates by reference, both the state and federal antidegradation policies. The permitted discharge must be consistent with the antidegradation provision of section 131.12 and State Water Board Resolution 68-16.
7. **Anti-Backsliding Requirements.** CWA sections 402(o) and 303(d)(4) and 40 C.F.R. section 122.44(l) restrict backsliding in NPDES permits. These anti-backsliding provisions require that effluent limitations in a reissued permit be as stringent as those in the previous permit, with some exceptions in which limitations may be relaxed. All effluent limitations in this Order are at least as stringent as the effluent limitations in the previous Order.
8. **Endangered Species Act Requirements.** This Order does not authorize any act that results in the taking of a threatened or endangered species or any act that is now prohibited, or becomes prohibited in the future, under either the California Endangered Species Act (Fish and Game Code §§ 2050 to 2097) or the Federal Endangered Species Act (16 U.S.C.A. §§ 1531 to 1544). This Order requires compliance with effluent limits, receiving water limits, and other requirements to protect the beneficial uses of waters of the State, including protecting rare, threatened, or endangered species. The Discharger is responsible for meeting all applicable Endangered Species Act requirements.

D. Impaired Water Bodies on CWA 303(d) List

CWA section 303(d) requires states to identify specific water bodies where water quality standards are not expected to be met after implementation of technology-based effluent limitations on point sources. For all 303(d) listed water bodies and pollutants, the Central Coast Water Board must develop and implement Total Maximum Daily Loads (TMDLs) that will specify Waste Load Allocations (WLAs) for point sources and Load Allocations (LAs) for

non-point sources.

The USEPA approved the State's 2012 303(d) list of impaired water bodies on July 30, 2015. The 2012 303(d) list identifies Soquel Creek as impaired for enterococcus, *E. coli*, fecal coliform, and turbidity. Bacteria TMDLs are currently in place and the TMDL for turbidity is expected to be completed in 2021.

The discharges addressed by this Order do not discharge to the segment of Soquel Creek applicable to the Bacteria TMDL. The segment of Soquel Creek applicable to the TMDL includes the downstream most reach of Soquel Creek, up to and including Soquel Creek at the bridge crossing at Porter Street, and is located more than 5 miles downstream of the discharge location. Additionally, the source analysis identifies municipally owned and operated separate storm sewer systems (MS4s), sanitary sewer collection systems spills and leaks, domestic animal waste, and a homeless person encampment as contributing to the downstream impairment. Because the Facility discharge is located outside of the applicable segment of Soquel Creek, is not identified as a contributing source of impairment, and the discharge is not composed of wastewater likely to contain elevated concentrations of bacteria that may contribute to downstream impairment, effluent limitations for bacteria have not been established in this Order.

E. Other Plans, Policies and Regulations

2. Discharges of Storm Water

For the control of storm water discharged from the quarry site through Discharge Points Nos. 001, 003, 004, and 005, the Order requires the Discharger to seek authorization to discharge under and meet the requirements of the State Water Resources Control Board's Water Quality Order 2014-0057-DWQ, NPDES General Permit No. CAS000001, *General Permit for Storm Water Discharges Associated with Industrial Activities*.

IV. RATIONALE FOR EFFLUENT LIMITATIONS AND DISCHARGE SPECIFICATIONS

The CWA requires point source dischargers to control the amount of conventional, non-conventional, and toxic pollutants that are discharged into the waters of the United States. The control of pollutants discharged is established through effluent limitations and other requirements in NPDES permits. There are two principal bases for effluent limitations in the Code of Federal Regulations: 40 C.F.R. section 122.44(a) requires that permits include applicable technology-based limitations and standards; and 40 C.F.R. section 122.44(d) requires that permits include water quality-based effluent limitations to attain and maintain applicable numeric and narrative water quality criteria to protect the beneficial uses of the receiving water.

A. Discharge Prohibitions

- 1. Discharge Prohibition III.A.** (No discharge at a location or in a manner except as described by the Order). The Order authorizes a single, specific point of discharge to surface waters, and the limitations and conditions established by the Order are based on specific information provided by the Discharger and gained by the Regional Water Board through site visits, monitoring reports, and other information. Discharges to surface waters at locations not contemplated by this Order or discharges of a character not contemplated by this Order are therefore viewed as inconsistent with CWA section 402's prohibition against discharges of pollutants except in compliance with the Act's permit requirements, effluent limitations, and other enumerated provisions. This prohibition is retained from the previous permit.

2. **Discharge Prohibition III.B.** (The discharge of any waste not specifically regulated by this Permit is prohibited). Because limitations and conditions of the Order have been prepared based on specific information provided by the Discharger and specific wastes described by the Discharger, the limitations and conditions of the Order do not adequately address waste streams not contemplated during drafting of the Order. To prevent the discharge of such waste streams that may be inadequately regulated, the Order prohibits the discharge of any waste that was not described by to the Regional Water Board during the process of permit reissuance.
3. **Discharge Prohibition III.C.** (Overflows and bypasses prohibited). The discharge of untreated or partially treated wastewater from the Discharger's collection, treatment, or disposal facilities represents an unauthorized bypass pursuant to 40 CFR 122.41 (m) or an unauthorized discharge, which poses a threat to human health and/or aquatic life, and therefore, is explicitly prohibited by the Order.
4. **Discharge Prohibition III.D.** (No adverse impacts to beneficial uses or threatened or endangered species). This prohibition is retained from the previous Order and is based on the Basin Plan, which, in accordance with CWC Section 13241, must include water quality objectives to ensure the reasonable protection of beneficial uses and the prevention of nuisance.
5. **Discharge Prohibition III.E.** (Creation of a condition of pollution, contamination, or nuisance, as defined by Section 13050 of the CWC, is prohibited). This prohibition is retained from the previous permit.
6. **Discharge Prohibition III.F.** (Discharge of fuels, greases or oils is prohibited). This prohibition is retained from the previous Order.
7. **Discharge Prohibition III.G.** (Discharge of radioactive substances is prohibited). This prohibition is retained from the previous Order.

B. Technology-Based Effluent Limitations

1. Scope and Authority

CWA section 301(b) and 40 C.F.R. section 122.44 require that permits include conditions meeting technology-based requirements at a minimum, and any more stringent effluent limitations necessary to meet water quality standards. The discharges authorized by this Order must meet minimum federal technology-based requirements based on Effluent Limitations Guidelines and Standards (ELGs) for the Mineral Mining and Processing Category in 40 CFR Part 436 and limitations from the previous order.

The CWA requires USEPA to develop ELGs representing application of best practicable treatment control technology (BPT), best available technology economically available (BAT), best conventional pollutant control technology (BCT), and new source performance standards (NSPS).

2. Applicable Technology-Based Effluent Limitations

Effluent limitations, guidelines and standards for discharges from this Facility are covered under the Mineral Mining and Processing Point Source Category, Subpart B - Crushed Stone Subcategory (40 CFR 436.22). The following effluent limitations, representing the degree of effluent reduction attainable by the application of BPT, for discharges from the Facility shall not exceed the following limitations at Discharge Point No. 002.

Table F-4. Effluent Limitations Guidelines

| Effluent Characteristic | Units | Effluent Limitations | |
|-------------------------|----------------|--------------------------------|---|
| | | Maximum for any 1 day | Average of daily values for 30 consecutive days shall not exceed— |
| pH | standard units | Within the range of 6.0 to 9.0 | |

Water quality-based effluent limitations for pH discussed in section IV.C.6 are more stringent than the applicable ELGs, and have been established in the Order.

The previous permit, Order No. R3-2010-0039, established additional technology-based effluent limitations for settleable solids and TSS. Consistent with State and federal antibacksliding requirements, these limitations have been carried over.

Table F-5. Additional Technology-Based Effluent Limitations Retained from Previous Order

| Parameter | Units | Effluent Limitations | |
|-------------------|-------|----------------------|-----------------|
| | | Maximum Daily | Average Monthly |
| Settleable Solids | mL/L | --- | 0.3 |
| TSS | mg/L | 50 | --- |

C. Water Quality-Based Effluent Limitations

1. Scope and Authority

CWA Section 301(b) and 40 C.F.R. section 122.44(d) require that permits include limitations more stringent than applicable federal technology-based requirements where necessary to achieve applicable water quality standards, including numeric and narrative objectives within a standard.

40 C.F.R. Section 122.44(d)(1)(i) requires that permits include effluent limitations for all pollutants that are or may be discharged at levels that have the reasonable potential to cause or contribute to an exceedance of a water quality standard, including numeric and narrative objectives within a standard. Where reasonable potential has been established for a pollutant, but there is no numeric criterion or objective for the pollutant, water quality-based effluent limitations (WQBELs) must be established using: (1) U.S. EPA criteria guidance under CWA section 304(a), supplemented where necessary by other relevant information; (2) an indicator parameter for the pollutant of concern; or (3) a calculated numeric water quality criterion, such as a proposed state criterion or policy interpreting the state’s narrative criterion, supplemented with other relevant information, as provided in section 122.44(d)(1)(vi).

The process for determining reasonable potential and calculating WQBELs, when necessary, is intended to protect the designated uses of receiving waters as specified in the Basin Plan and achieve applicable WQOs and criteria that are contained in other state plans and policies, or any applicable water quality criteria contained in the CTR and NTR.

2. Applicable Beneficial Uses and Water Quality Criteria and Objectives

Beneficial uses described by the Basin Plan for Soquel Creek are presented in section III.C.1 of this Fact Sheet. Water quality criteria applicable to this receiving water are established by the CTR, the NTR, and by the Basin Plan and include the following:

- a. Water quality criteria for the protection of aquatic life and human health for 126 priority, toxic pollutants established by the NTR and the CTR and described at 40 CFR 131.38.
- b. General objectives for all inland surface waters, established by Section II.A.2 of the Basin Plan.
- c. Specific objectives for inland surface waters established by Section II.A.2 of the Basin Plan for the protection of municipal and domestic supplies. These criteria include the primary maximum contaminant levels for inorganic and organic chemicals presented in Tables 64431-A and 64444-A, respectively, of the California Code of Regulations Title 22, Division 4, Chapter 15.
- d. Specific objectives for inland surface waters established in Section II.A.2 of the Basin Plan for the protection of agricultural water supplies, including those presented in Tables 3-3 and 3-4 of the Basin Plan.
- e. Specific objectives for inland surface waters established by Section II.A.2 of the Basin Plan for the protection of water contact and non-water contact water recreation.
- f. Specific objectives for inland surface waters established by Section II.A.2 of the Basin Plan for the protection of cold freshwater habitat and fish migration and spawning, including those presented in Table 3-5 of the Basin Plan.

3. Determining the Need for WQBELs

NPDES regulations at 40 C.F.R. 122.44(d) require effluent limitations to control all pollutants which are or may be discharged at a level which will cause, have the reasonable potential to cause, or contribute to an excursion above any State water quality standard.

The SIP, statewide policy that became effective on May 22, 2000, establishes procedures to implement water quality criteria from the NTR and CTR and for priority, toxic pollutant objectives established in the Basin Plan. The implementation procedures of the SIP include methods to determine reasonable potential (for pollutants to cause or contribute to excursions above State water quality standards) and to establish numeric effluent limitations, if necessary, for those pollutants which show reasonable potential.

The SIP Section 1.3 requires the Regional Water Board to use all available, valid, relevant, and representative receiving water and effluent data and information to conduct a reasonable potential analysis (RPA). Effluent data for the discharge at Discharge Point No. 002 was not available because there were no discharges at Discharge Point No. 002 during the previous permit term. Discharge Points No. 001, 003, 004 and 005 only discharge storm water and are regulated under the State Water Resources Control Board's Water Quality Order 2014-0057-DWQ, NPDES General Permit No. CAS000001, *Waste Discharge Requirements for Discharges of Storm Water*

Associated with Industrial Activities. Therefore, an RPA was not conducted for any of the discharge points to Soquel Creek.

4. **WQBEL Calculations**

Effluent data for the discharge at Discharge Point No. 002 was not available because there were no discharges at Discharge Point No. 002 during the previous permit term. Therefore, no WQBEL calculations were performed and, with some exceptions, effluent limitations were retained from Order R3-2010-0039. Effluent limitations for chromium III, and phenol were revised to be protective of applicable water quality objectives and calculated consistent with the SIP method for the protection of human health. The revised limitation for chromium III is based on the primary maximum contaminant level of 50 µg/L. The revised limitation for phenol is based on Section II.A.2.a of the Basin Plan for waters with municipal beneficial uses (1.0 µg/L).

The limitations are conservative because no mixing zone is provided and sampling must occur only when the ponds discharge, likely during periods of high rainfall when substantial dilution will occur.

5. **Whole Effluent Toxicity (WET)**

Effluent limitations for whole effluent toxicity protect the receiving water from the aggregate effect of a mixture of pollutants that may be present in effluent. There are two types of WET tests – acute and chronic. An acute toxicity test is conducted over a short time period and measures mortality. A chronic test is conducted over a longer period of time and may measure mortality, reproduction, and/or growth.

WET requirements are derived from the CWA and the Basin Plan. The Basin Plan establishes a narrative water quality objective for toxicity that states “*All waters shall be maintained free of toxic substances in concentrations which are toxic to, or which produce detrimental physiological responses in, human, plant, or aquatic life.*” Detrimental responses may include, but are not limited to, decreased growth rate, decreased reproductive success of resident or indicator species, and/or significant alterations in population, community ecology, or receiving water biota. The previous order required acute toxicity testing and an acute toxicity limitation. Acute toxicity testing is not sufficient for determining compliance with the Basin Plan’s narrative toxicity objective, because non-lethal effects are not measured. Testing for chronic toxicity is more conservative, therefore this Order establishes a chronic toxicity limitation in lieu of an acute toxicity limitation. The Permittee is required to conduct WET testing for chronic toxicity, as specified in the MRP (Attachment E, section V).

a. **Chronic Aquatic Toxicity**

The SIP requires the use of short-term chronic toxicity tests to determine compliance with the narrative toxicity objectives for aquatic life in the Basin Plan. The SIP requires that the Permittee demonstrate the presence or absence of chronic toxicity using tests on the fathead minnow, *Pimephales promelas*, the water flea, *Ceriodaphnia dubia*, and the freshwater alga, *Selenastrum capricornutum* (also named *Raphidocelis subcapitata*). Attachment E of this Order requires biennial chronic WET monitoring to demonstrate compliance with the narrative toxicity objective.

To ensure compliance with the narrative effluent limitation and the Basin Plan's narrative toxicity objective, the Permittee is required to conduct biennial chronic WET testing at Discharge Point No. 002, as specified in the MRP (Attachment E, section V). Furthermore, the MRP (Attachment E, section V.C) requires the Permittee to investigate the causes of, and identify and implement corrective actions to reduce or eliminate effluent toxicity. If the discharge demonstrates a result of "Fail" or "F", the Permittee is required to initiate a TRE in accordance with an approved TRE work plan.

Test of Significant Toxicity (TST)

In 2010, U.S. EPA endorsed the peer-reviewed *Test of Significant Toxicity (TST) two-concentration hypothesis testing approach in National Pollutant Discharge Elimination System Test of Significant Toxicity Implementation Document* (EPA 833-R-10-003, 2010) as an improved hypothesis-testing tool to evaluate data from U.S. EPA's toxicity test methods. The TST hypothesis testing approach more reliably identifies toxicity—in relation to the chronic (0.25 or more) mean response of regulatory management concern—than the NOEC hypothesis-testing approach. The TST hypothesis testing approach more reliably identifies toxicity – in relation to the acute (0.20 or more) mean responses of regulatory management concern – than the No Observed Effect Concentration (NOEC) approach used previously to establish effluent limitations for acute toxicity.

The State Water Board is developing a toxicity amendment to the *Water Quality Control Plan for Enclosed Bays and Estuaries of California* that will standardize the regulation of aquatic for all non-oceanic surface waters. U.S. EPA's TST approach is an essential component of this draft toxicity amendment as it forms the basis for utilizing numeric water quality objectives and acts as the primary means of determining compliance with the proposed effluent limitations.

In a letter dated February 12, 2014, the State Water Board submitted an alternative test process (ATP) request to U.S. EPA Region 9 for the statewide use of a two-concentration toxicity test design when using the TST approach. This two-concentration test design is composed of a single effluent concentration and a control concentration. U.S. EPA approved the ATP request on March 17th, 2014. In June 2014, the approval was challenged in court on procedural grounds under the Administrative Procedures Act by the Southern California Alliance of Publicly Owned Treatment Works (SCAP) and the Central Valley Clean Water Association (CVCWA). The U.S. EPA withdrew the approval and notified State Water Board in a memo dated February 11, 2015.

It is important to note that U.S. EPA's rescission of its approval of the ATP is not based on the substantive TST statistical analysis or the scientific validity of a two-concentration test design. The withdrawal letter also states that currently there is a proposed rulemaking to change the language in the ATP regulations at 40 C.F.R. part 136.

The benefits of requiring the TST in new or amended permits include improving the statistical power of the toxicity test, and simplifying the analysis as compared to the traditional hypothesis statistical approaches or point estimates. The calculations are straightforward and provide a clear pass/fail result. With the withdrawal of the two-concentration test design approval, an NPDES permit can still require the TST for

statistical analyses. Toxicity tests shall be run using a multi-concentration tests design in accordance with 40 C.F.R. section 136.3, and the TST shall be utilized with the biological responses from the permitted in-stream waste concentration (IWC) and the control (effluent concentration of zero). However, even with only two of the five concentration biological responses being used, cost savings in the form of time and effort are still realized for the statistical analysis and data interpretation carried out by the Permittee, lab, and permit manager. This Order requires application of TST for statistical analysis of whole effluent toxicity data.

Tests of Significant Toxicity Design

The TST's null hypothesis for chronic toxicity is:

H₀: Mean response (In-stream Waste Concentration (IWC) in % effluent) ≤ 0.75 mean response (control)

Results are analyzed using the TST approach and an acceptable level of chronic toxicity is demonstrated by rejecting the null hypothesis and reporting "Pass" or "P".

The chronic IWC (in % effluent) for Discharge Point No. 002 is 100%. The chronic toxicity trigger for Discharge Point No. 002 is expressed as a null hypothesis (H₀) and regulatory management decision (b value) of 0.75 for the chronic toxicity methods in the MRP. The null hypothesis for this discharge is:

H₀: Mean response (100% effluent) ≤ 0.75 mean response (control)

Results shall be analyzed using the TST hypothesis testing approach in the MRP. Compliance with this chronic toxicity limitation is demonstrated by rejecting the null hypothesis and reporting "Pass" or "P".

When the chronic toxicity test results in a "Fail" or "F," the Permittee must initiate accelerated monitoring as specified in the MRP (Attachment E, section V). After accelerated monitoring, if conditions of chronic toxicity are found to persist, the Permittee will be required to conduct a TRE, as described by the MRP.

Notification requirements for chronic WET testing include a 72-hour verbal notification requirement and a 14 day written report requirement, if test results indicate toxicity. The 14 day written notification is established in the U.S. EPA WET Guidance documents cited in the MRP. The 72-hour verbal notification requirement is being added to provide the Regional Water Board with knowledge of the toxicity in advance of the written report. The 72-hour requirement is intended to give the Permittee sufficient time to make a telephone call to Regional Water Board staff and accounts for non-working days (e.g., weekends). Verbal notification of WET test exceedances may be left by voice mail if the Regional Water Board staff person is not immediately available by telephone.

This Order includes a requirement for the Permittee to conduct a screening test using at least one vertebrate, invertebrate, and plant species. After the screening test is completed, monitoring can be reduced to the most sensitive species.

6. pH

Section II.A.2.a. of the Basin Plan requires that the pH shall not be depressed below 7.0 to protect the cold freshwater habitat beneficial use or raised above 8.3 to protect the municipal and domestic supply, agricultural supply, water contact recreation, and non-contact water recreation beneficial uses. Effluent limitations for pH are established in this Order for discharges at Discharge Point No. 002 consistent with the Basin Plan, which are protective of the receiving water beneficial uses.

D. Final Effluent Limitation Considerations

1. Anti-Backsliding Requirements

This Order complies with the anti-backsliding provisions of CWA sections 402(o) and 303(d)(4) and 40 C.F.R. section 122.44(l), which generally require effluent limitations in a reissued permit to be as stringent as those in the previous permit. The requirements of this Order are at least as stringent as those in the previous order.

2. Antidegradation Policies

This Order complies with the antidegradation provisions of 40 C.F.R. section 131.12 and State Water Board Resolution No. 68-16. It continues the status quo with respect to the level of discharge authorized in the previous order, which is the baseline by which to measure whether degradation will occur. This Order does not allow for a reduced level of treatment or increase effluent limitations relative to those in the previous order.

3. Stringency of Requirements for Individual Pollutants

This Order contains both technology-based and water quality-based effluent limitations for individual pollutants. The technology-based effluent limitations consist of restrictions on pH, TSS and Settleable solids. Restrictions on these pollutants are discussed in section IV.B of the Fact Sheet. This Order's technology-based pollutant restrictions implement the minimum, applicable federal technology-based requirements. In addition, this Order contains effluent limitations more stringent than the minimum, federal technology-based requirements that are necessary to meet water quality standards. Collectively, this Order's restrictions on individual pollutants are no more stringent than required to implement CWA requirements.

4. Summary of Final Effluent Limitations – Discharge Point No. 002

- a. The Discharger shall maintain compliance with the following effluent limitations at Discharge Point No. 002, with compliance measured at Monitoring Location EFF-002 as described in the attached Monitoring and Reporting Program (MRP) (Attachment E).

Table F-6. Final Effluent Limitations

| Parameter | Units | Effluent Limitations | |
|------------------------------|----------------|------------------------|------------------|
| | | Average Monthly | Maximum Daily |
| pH | standard units | 7.0 – 8.3 at all times | |
| Total Suspended Solids (TSS) | mg/L | --- | 50 |
| Settleable Solids | ml/L | 0.3 | --- |
| Acute Toxicity | TUa | --- | 1 ^[1] |
| Mercury, Total Recoverable | µg/L | 0.050 | 0.10 |

| Parameter | Units | Effluent Limitations | |
|-----------------------------------|----------|----------------------|---------------|
| | | Average Monthly | Maximum Daily |
| Selenium, Total Recoverable | µg/L | 10 | 20 |
| Cyanide, Total Recoverable | µg/L | 4.3 | 8.5 |
| Antimony, Total Recoverable | µg/L | 6.0 | 12 |
| Arsenic, Total Recoverable | µg/L | 50 | 100 |
| Beryllium, Total Recoverable | µg/L | 4.0 | 8.0 |
| Cadmium, Total Recoverable | µg/L | 5.0 | 10 |
| Chromium (III), Total Recoverable | µg/L | 50 | 100 |
| Chromium (IV), Total Recoverable | µg/L | 8.1 | 16 |
| Copper, Total Recoverable | µg/L | 22 | 44 |
| Lead, Total Recoverable | µg/L | 13 | 25 |
| Nickel, Total Recoverable | µg/L | 100 | 201 |
| Silver, Total Recoverable | µg/L | 17 | 34 |
| Thallium, Total Recoverable | µg/L | 1.7 | 3.4 |
| Zinc, Total Recoverable | µg/L | 164 | 329 |
| Asbestos | fibers/L | 7,000,000 | 14,000,000 |
| 2,3,7,8 TCDD | µg/L | 0.00000013 | 0.00000026 |
| Acrolein | µg/L | 320 | 642 |
| Acrylonitrile | µg/L | 0.059 | 0.12 |
| Benzene | µg/L | 1.0 | 2.0 |
| Bromoform | µg/L | 4.3 | 8.6 |
| Carbon Tetrachloride | µg/L | 0.25 | 0.50 |
| Chlorobenzene | µg/L | 30 | 60 |
| Chlorodibromomethane | µg/L | 0.40 | 0.80 |
| Chloroform | µg/L | 80 | 160 |
| Dichlorobromomethane | µg/L | 0.56 | 1.12 |
| 1,1-Dichloroethane | µg/L | 5.0 | 10 |
| 1,2-Dichloroethane | µg/L | 0.38 | 0.76 |
| 1,1-Dichloroethylene | µg/L | 0.057 | 0.11 |
| 1,2-Dichloropropane | µg/L | 0.52 | 1.0 |
| 1,3-Dichloropropylene | µg/L | 0.50 | 1.0 |
| Ethylbenzene | µg/L | 300 | 602 |
| Methyl Bromide | µg/L | 48 | 96 |
| Methylene Chloride | µg/L | 4.7 | 9.4 |
| 1,1,2,2-Tetrachloroethane | µg/L | 0.17 | 0.34 |
| Tetrachloroethylene | µg/L | 0.80 | 1.6 |
| Toluene | µg/L | 150 | 301 |
| 1,2-Trans-Dichloroethylene | µg/L | 10 | 20 |
| 1,1,1-Trichloroethane | µg/L | 200 | 401 |
| 1,1,2-Trichloroethane | µg/L | 0.60 | 1.2 |
| Trichloroethylene | µg/L | 2.7 | 5.4 |
| Vinyl Chloride | µg/L | 0.50 | 1.0 |
| 2-Chlorophenol | µg/L | 120 | 241 |
| 2,4-Dichlorophenol | µg/L | 93 | 187 |
| 2,4-Dimethylphenol | µg/L | 540 | 1,083 |

| Parameter | Units | Effluent Limitations | |
|-----------------------------|-------|----------------------|---------------|
| | | Average Monthly | Maximum Daily |
| 2-methyl-4,6-dinitrophenol | µg/L | 13 | 27 |
| 2,4-Dinitrophenol | µg/L | 70 | 140 |
| Pentachlorophenol | µg/L | 0.28 | 0.56 |
| Phenol | µg/L | 1.0 | 2.0 |
| 2,4,6-Trichlorophenol | µg/L | 2.1 | 4.2 |
| Acenaphthene | µg/L | 1,200 | 2,407 |
| Anthracene | µg/L | 9,600 | 19,259 |
| Benzidine | µg/L | 0.00012 | 0.00024 |
| Benzo(a)Anthracene | µg/L | 0.0044 | 0.0088 |
| Benzo(a)Pyrene | µg/L | 0.0044 | 0.0088 |
| Benzo(b)Fluoranthene | µg/L | 0.0044 | 0.0088 |
| Benzo(k)Fluoranthene | µg/L | 0.0044 | 0.0088 |
| Bis(2-Chloroethyl)Ether | µg/L | 0.031 | 0.062 |
| Bis(2-Chloroisopropyl)Ether | µg/L | 1,400 | 2,809 |
| Bis(2-Ethylhexyl)Phthalate | µg/L | 1.8 | 3.6 |
| Butylbenzyl Phthalate | µg/L | 3,000 | 6,019 |
| 2-Chloronaphthalene | µg/L | 1,700 | 3,411 |
| Chrysene | µg/L | 0.0044 | 0.0088 |
| Dibenzo(a,h)Anthracene | µg/L | 0.0044 | 0.0088 |
| 1,2-Dichlorobenzene | µg/L | 600 | 1,204 |
| 1,3-Dichlorobenzene | µg/L | 400 | 802 |
| 1,4-Dichlorobenzene | µg/L | 5.0 | 10 |
| 3,3-Dichlorobenzidine | µg/L | 0.040 | 0.1 |
| Diethyl Phthalate | µg/L | 23,000 | 46,142 |
| Dimethyl Phthalate | µg/L | 313,000 | 627,937 |
| Di-n-Butyl Phthalate | µg/L | 2,700 | 5,417 |
| 2,4-Dinitrotoluene | µg/L | 0.11 | 0.22 |
| 1,2-Diphenylhydrazine | µg/L | 0.040 | 0.080 |
| Fluoranthene | µg/L | 300 | 602 |
| Fluorene | µg/L | 1,300 | 2,608 |
| Hexachlorobenzene | µg/L | 0.00075 | 0.0015 |
| Hexachlorobutadiene | µg/L | 0.44 | 0.88 |
| Hexachlorocyclopentadiene | µg/L | 50 | 100 |
| Hexachloroethane | µg/L | 1.9 | 3.8 |
| Indeno(1,2,3-cd)Pyrene | µg/L | 0.0044 | 0.0088 |
| Isophorone | µg/L | 8.4 | 17 |
| Nitrobenzene | µg/L | 17 | 34 |
| N-Nitrosodimethylamine | µg/L | 0.00069 | 0.0014 |
| N-Nitrosodi-n-Propylamine | µg/L | 0.0050 | 0.010 |
| N-Nitrosodiphenylamine | µg/L | 5.0 | 10 |
| Pyrene | µg/L | 960 | 1,926 |
| 1,2,4-Trichlorobenzene | µg/L | 5.0 | 10 |
| Aldrin | µg/L | 0.00013 | 0.00026 |
| alpha-BHC | µg/L | 0.0039 | 0.0078 |

| Parameter | Units | Effluent Limitations | |
|-------------------------|-------|----------------------|---------------|
| | | Average Monthly | Maximum Daily |
| beta-BHC | µg/L | 0.014 | 0.028 |
| gamma-BHC | µg/L | 0.019 | 0.038 |
| Chlordane | µg/L | 0.00057 | 0.0011 |
| 4,4'-DDT | µg/L | 0.00059 | 0.0012 |
| 4,4'-DDE | µg/L | 0.00059 | 0.0012 |
| 4,4'-DDD | µg/L | 0.00083 | 0.0017 |
| Dieldrin | µg/L | 0.00014 | 0.00028 |
| alpha-Endosulfan | µg/L | 0.046 | 0.092 |
| beta-Endosulfan | µg/L | 0.046 | 0.092 |
| Endosulfan Sulfate | µg/L | 110 | 221 |
| Endrin | µg/L | 0.029 | 0.059 |
| Endrin Aldehyde | µg/L | 0.76 | 1.5 |
| Heptachlor | µg/L | 0.00021 | 0.00042 |
| Heptachlor Epoxide | µg/L | 0.00010 | 0.00020 |
| PCBs sum ^[2] | µg/L | 0.00017 | 0.00034 |
| Toxaphene | µg/L | 0.00016 | 0.00033 |

[1] The limitation for chronic toxicity shall be "Pass" or "P" as described in Section V.A.. of the Monitoring and Reporting Program (MRP) attached to this Order.

[2] Includes aroclors 1242, 1254, 1221, 1232, 1248, 1260, and 1016.

E. Reclamation Specifications – Not Applicable

V. RATIONALE FOR RECEIVING WATER LIMITATIONS

A. Surface Water

The receiving water limitations in sections V.A and V.B of the Order are based on Basin Plan narrative and numeric water quality objectives.

B. Groundwater – Not Applicable

VI. RATIONALE FOR MONITORING AND REPORTING REQUIREMENTS

40 CFR Section 122.48 requires that all NPDES permits specify requirements for recording and reporting monitoring results. Water Code sections 13267 and 13383 authorize the Central Coast Water Board to require technical and monitoring reports. The Monitoring and Reporting Program (MRP), Attachment E, establishes monitoring and reporting requirements that implement federal and state requirements. The following provides the rationale for the monitoring and reporting requirements contained in the MRP for this facility.

A. Influent Monitoring – Not Applicable

B. Effluent Monitoring

Effluent monitoring is necessary to determine compliance with effluent limitations and evaluate compliance with applicable water quality objectives and criteria. Effluent monitoring requirements from the previous Order (R3-2010-0039) for Discharge Point No. 002 are retained in this Order.

C. Whole Effluent Toxicity Testing Requirements

WET limitations protect receiving water quality from the aggregate toxic effect of a mixture of pollutants in the effluent. Acute toxicity testing measures mortality in 100 percent effluent over a short test period and chronic toxicity testing is conducted over a longer period of time and may measure mortality, reproduction, and/or growth. The previous order required acute toxicity testing and an acute toxicity limitation. Acute toxicity testing is not sufficient for determining compliance with the Basin Plan's narrative toxicity objective, because long term effects are not measured. Testing for chronic toxicity is more conservative, therefore this Order establishes a chronic toxicity limitation implementing the TST method as outlined in section IV.C.5 of this Fact Sheet, in lieu of an acute toxicity limitation.

D. Reclaimed Water Monitoring – Not Applicable

E. Receiving Water Monitoring

Surface water receiving water monitoring requirements are necessary to evaluate compliance with water quality objectives and the protection of beneficial uses. Receiving water monitoring requirements are retained from the previous order.

F. Land Discharge Monitoring Requirements – Not Applicable

G. Other Monitoring Requirements – Not Applicable

VII. RATIONALE FOR PROVISIONS

A. Standard Provisions

Standard Provisions, which apply to all NPDES permits in accordance with 40 C.F.R. section 122.41, and additional conditions applicable to specified categories of permits in accordance with 40 C.F.R. section 122.42, are provided in Attachment D to the order.

Sections 122.41(a)(1) and (b) through (n) of 40 C.F.R. establish conditions that apply to all State-issued NPDES permits. These conditions must be incorporated into the permits either expressly or by reference. If incorporated by reference, a specific citation to the regulations must be included in the Order. Section 123.25(a)(12) allows the State to omit or modify conditions to impose more stringent requirements. In accordance with 40 C.F.R. section 123.25, this Order omits federal conditions that address enforcement authority specified in 40 C.F.R. sections 122.41(j)(5) and (k)(2) because the enforcement authority under the Water Code is more stringent. In lieu of these conditions, this Order incorporates by reference Water Code section 13387(e).

B. Special Provisions

1. Reopener Provisions

The Order may be modified in accordance with the requirements set forth at 40 CFR 122 and 124, to include appropriate conditions or limits based on newly available information, or to implement any new State water quality objectives that are approved by the U.S. EPA. As effluent is further characterized through additional monitoring, and if a need for additional effluent limitations becomes apparent after additional effluent characterization, the Order will be reopened to incorporate such limitations.

2. Special Studies and Additional Monitoring Requirements

The Order retains the requirement to maintain a Toxicity Reduction Work Plan from Order No. R3-2010-0039. When toxicity monitoring measures acute toxicity in the effluent above the limitation established by the Order, the Discharger is required to resample and retest, if the discharge is continuing. When all monitoring results are available, the Executive Officer can determine whether to initiate enforcement action, whether to require the Discharger to implement toxicity reduction evaluation (TRE) requirements, or whether other measures are warranted.

3. Best Management Practices and Pollution Prevention – Not Applicable

4. Construction, Operation, and Maintenance Specifications

a. Erosion and Sediment Control

The requirement to inspect, install, and have in proper operational condition all erosion and sediment control systems necessary to assure compliance with this Order is retained from Order No. R3-2010-0039.

5. Special Provisions for Municipal Facilities (POTWs Only) – Not Applicable

6. Other Special Provisions

a. Discharges of Storm Water.

This Order applies to discharges of process wastewater and storm water from Discharge Point No. 002. All other storm water runoff from the Olive Springs Quarry can be discharged only in accordance with the requirements of the State Water Resources Control Board's Water Quality Order 2014-0057-DWQ, NPDES General Permit No. CAS000001, *General Permit for Storm Water Discharges Associated with Industrial Activities*.

b. Timber Harvesting Plan.

Order No. R3-2010-0039 required that the Discharger collect, treat, and monitor all runoff from the timber harvesting site harvested in accordance with the Timber Harvesting Plan (No. 1-04-138 SCR) approved by the Director of Forestry on February 16, 2005. This provision has been retained in this Order to ensure compliance with the harvesting plan.

7. Compliance Schedules – Not Applicable

VIII. PUBLIC PARTICIPATION

The Central Coast Water Board has considered the issuance of WDR's that will serve as an NPDES permit for the Olive Springs Quarry. As a step in the WDR adoption process, the Central Coast Water Board staff has developed tentative WDR's and has encouraged public participation in the WDR adoption process.

A. Notification of Interested Parties

The Central Coast Water Board notified the Discharger and interested agencies and persons of its intent to prescribe WDR's for the discharge and provided an opportunity to submit written comments and recommendations. Notification was provided through the publication in local paper and posting at the Facility.

The public had access to the agenda and any changes in dates and locations through the Central Coast Water Board's web site at:
<http://www.waterboards.ca.gov/centralcoast/>

B. Written Comments

Interested persons were invited to submit written comments concerning tentative WDR's as provided through the notification process. Comments were due either in person or by mail to the Executive Office at the Central Coast Water Board at:

Central Coast Regional Water Quality Control Board
895 Aerovista Place, Suite 101
San Luis Obispo, CA 93401-7906

To be fully responded to by staff and considered by the Central Coast Water Board, the written comments were due at the Central Coast Water Board office by 5:00 p.m. on May 12, 2017.

C. Public Hearing

The Central Coast Water Board held a public hearing on the tentative WDR's during its regular Board meeting on the following date and time and at the following location:

Date: July 13, 2017
Time: 8am-5pm
Location: Watsonville City Council Chambers
275 Main Street - 4th Floor (new bldg)
Watsonville, CA 95076

Interested persons were invited to attend. At the public hearing, the Central Coast Water Board heard testimony, pertinent to the discharge, WDR's, and permit. For accuracy of the record, important testimony was requested in writing.

D. Reconsideration of Waste Discharge Requirements

Any aggrieved person may petition the State Water Board to review the decision of the Regional Water Board regarding the final WDR's. The petition must be received by the State Water Board at the following address within 30 calendar days of the Regional Water Board's action.

State Water Resources Control Board
Office of Chief Counsel
P.O. Box 100, 1001 I Street
Sacramento, CA 95812-0100

For instructions on how to file a petition for review, see:
http://www.waterboards.ca.gov/public_notices/petitions/water_quality/wqpetition_instr.shtml

E. Information and Copying

The Report of Waste Discharge, other supporting documents, and comments received are on file and may be inspected at the address above at any time between 8:30 a.m. and 4:45 p.m., Monday through Friday. Copying of documents may be arranged through the Central Coast Water Board by calling (805) 549-3147.

F. Register of Interested Persons

Any person interested in being placed on the mailing list for information regarding the WDR's and NPDES permit should contact the Central Coast Water Board reference this Facility, and provide a name, address, and phone number.

G. Additional Information

Requests for additional information or questions regarding this order should be directed to Katie DiSimone at (805) 542-4638 or at katie.disimone@waterboards.ca.gov